

# Udara

## INSTRUCTIONS FOR THE INSTALLER AND END USER

### INSTALLATION, COMMISSIONING, MAINTENANCE AND USE OF THE APPLIANCE

*Gas-fired condensing and modulating air heater with an automatically regulated energy-efficient fan with a direct current motor and gas-adaptive burner control*

Brand: Multicalor Udara

Model: 10, 15, 20, 30, 40 et 50 (DF)

Country of destination: United Kingdom (UK)



Read this document before starting the installation or using the appliance. After commissioning, give instructions to the user and keep this document in the immediate vicinity of the appliance. This appliance may not be operated by children, people with a diminished mental capacity, physical impairments or lack of knowledge unless under supervision or after receiving training on how to use the appliance safely and as long as they are aware of the possible risks. Children may not play with the appliance under any circumstances. Cleaning and maintenance performed by the user may never be carried out by children without supervision.

#### Multicalor Industries NV

Blarenberglaan 21 • B-2800 Malines  
Tel.: +32 15 29 03 03 • Fax: +32 15 29 03 20  
info@multicalor.be • www.multicalor.be

IHL\_UDARA\_2023\_BEGB

multi**calor**

Wijzigingen voorbehouden

## Table of contents

<b>1</b>	<b>Safety</b>	<b>5</b>
1.1	Warnings and symbols	5
1.2	Improper use	5
1.3	General safety instructions	5
<b>2</b>	<b>General information</b>	<b>8</b>
2.1	Description	8
2.2	Gas category	8
2.3	Standard version	8
2.4	Outdoor air version	8
2.5	Versions	8
<b>3</b>	<b>Technical data</b>	<b>9</b>
3.1	In general	9
3.2	Technical data	9
3.3	Overview of components	10
3.4	Dimensions	11
<b>4</b>	<b>Installation</b>	<b>12</b>
4.1	In general	12
4.2	Installation of the flue gas outlet system	12
4.3	Installation of the condensate drain	17
4.4	Installation of the gas pipe	17
4.5	Installation of the ductwork	18
<b>5</b>	<b>Commissioning</b>	<b>20</b>
5.1	Switching the appliance on and off	20
5.2	Regulating the combustion	20
5.3	Converting the appliance to propane	21
<b>6</b>	<b>Operating and setting</b>	<b>22</b>
6.1	In general	22
6.2	Modulating thermostat RC21	22
6.3	Air-conditioning	23
6.4	Heat pump	23
6.5	Operation in heating mode	23
6.6	Setting as ventilation	23
6.7	The control panel	23
6.8	Changing settings	24
6.9	Error codes	26
<b>7</b>	<b>Maintenance</b>	<b>27</b>
7.1	Maintenance by the user	27
7.2	Maintenance by the installer	27
<b>8</b>	<b>Troubleshooting</b>	<b>28</b>
8.1	Appliance does not start after 5 attempts	28
8.2	Internal error	29
8.3	Overheating and NTC errors	29
8.4	Display does not work	29
8.5	Flue gas fan operates continuously or not at all	29
8.6	System fan operates continuously or not at all	29
8.7	No communication with thermostat	29
8.8	Fuse or earth leakage circuit breaker intervenes	30
8.9	Loss of flame shortly after ignition	30
8.10	Service Request	30
8.11	Normal settings	30

<b>9</b>	<b>Diagram</b>	<b>31</b>
<b>10</b>	<b>Parts</b>	<b>32</b>
10.1	Parts list	32
10.2	Ordering procedure	32
10.3	Service request	32
<b>11</b>	<b>Guarantee</b>	<b>33</b>
11.1	In general	33
11.2	Scope and duration of the guarantee	33
11.3	Damage that is not covered by the guarantee	33
11.4	The following are not covered by the guarantee	33
11.5	Repairs	33
11.6	Service sets	33
<b>12</b>	<b>Multicalor RC21.14</b>	<b>34</b>
12.1	Setting the language, date and time	34
12.2	Mode	
12.3	Summer ventilation	36
12.4	Program	36
12.5	Switching off periods (max. of 2 periods)	37
<b>13</b>	<b>EC Declaration of conformity</b>	<b>38</b>
<b>14</b>	<b>Declaration of conformity KB 2004-01-08</b>	<b>39</b>

# 1 Safety

This section must be carefully studied by the installer and the user.

## 1.1 Warnings and symbols

A number of symbols point out possible dangers that may occur when installing or using the appliance.

Depending on the seriousness of the potential situation, other symbols, icons or words are used.

Always take these warnings seriously and never ignore them.



### Danger!

This symbol warns you about a serious danger. Intervene immediately to prevent heavy physical or fatal injury or significant material damage.



### Danger!

This symbol warns about a danger or fatal injury because of an electric shock. Ignoring this warning can lead to significant physical or fatal injury.



### Warning!

This symbol warns about a dangerous situation. Ignoring this warning can lead to physical injury, material damage or environmental damage.



### Attention!

This symbol warns about a situation that deserves your attention. Ignoring this warning can lead to material damage.



### Information(s)

This symbol indicates that somewhere else in the manual you can find more information about this topic or it will refer you to a local standard.

## 1.2 Improper use

The Udara air heater is intended for heating systems based on hot air where both the heated and the intake air is distributed through a system of ducts.

If the appliance is used inexpertly or improperly, a situation may be created that entails danger for the user or third parties or can lead to damage to the appliance or the environment.

You may only install the Udara if you combine the appliance with the accessories listed in the manual for the combustion air supply (CAS) and flue gas outlet (FGO).

As an installer or user you have the obligation to closely follow the instructions contained in the manual of the appliance or the possible accessories. You

must, moreover, respect all inspection and maintenance conditions

You must connect the appliance electrically in accordance with the protection degree specified on the nameplate and in accordance with the locally applicable regulations.

If you implement changes to the appliance that are not described in the manual, you must ask for written permission from the manufacturer.

Transgressions to these instructions will be deemed not according to the regulations and may lead to dangerous situations or material damage regarding which the manufacturer rejects any responsibility.

## 1.3 General safety instructions

The installation, mounting, disassembly, commissioning, maintenance and repair must only be performed by professionals. They must have all legal qualifications and, by preference, they must have followed training at the manufacturer of the appliance.

As a user, you must closely follow the maintenance instructions. Ask your installer to go through this section if you have any questions.

### 1.3.1 Danger of fatal injury because of gas leaks

With regard to gas smells in buildings:

- extinguish all naked flames (such as from smoking, cookers, etc.).
- Do not operate any doorbells, switches, plugs, telephones, entry panels or other devices
- Close the main gas valve and the gas valve on the product.
- Open windows and doors.
- Evacuate the building and stop third parties from entering the building.
- Warn the fire brigade using a telephone connection outside the building (for example, at the neighbours).
- If the leak occurs in front of the gas meter, warn the energy company.

Liquid gas is heavier than air and will collect near the floor. If the appliance is being installed below ground level, leaking liquid gas will collect and, therefore, there will be an explosion risk.

- Ensure that liquid gas can never escape from the appliance or the gas pipe.

### 1.3.2 Danger of fatal injury because of flammable substances

Do not use or keep explosive or flammable substances (petrol, thinner, paper, etc.) near the appliance.

### 1.3.3 Danger of fatal injury because of combustion gases escaping

If flue gases escape, this can lead to dangerous situations.

- Only use the appliance with a fully installed CAS/FGO

- Always use the appliance with an installed front cover.

A dangerous situation may occur if the appliance is supplied with insufficient combustion air.

- Ensure there is a permanent and unobstructed air supply to the set-up room of the appliance in accordance with the applicable standards.

If you smell flue gases or you suspect there is a combustion gas leak, you must intervene immediately.

- Open windows and doors and ventilate the building.
- Switch off the product.
- Consult your installer and have the combustion circuit checked for leaks or obstructions.

If the condensate trap is empty, flue gas may leak.

- Always use the appliance with a fully filled condensate trap.

### **1.3.4 Danger of fatal injury because of electric shocks**

If you touch components that carry a current, there is a danger of fatal injury because of an electric shock.

Before you work on the product:

- Ensure that the current to the appliance has been disconnected.
- Protect against reconnection.
- Always wait a few minutes so that the capacitors in motor controls, etc., are discharged.

### **1.3.5 Danger of fatal injury because of changes**

Unauthorised changes to the product or set-up room can lead to dangerous situations.

- Never remove, bypass or change the temperature probes in the appliance.
- Sealed parts in the appliance must not be opened.
- Never change the piping for gas or the CAS/FGO and the wiring for the voltage.
- The condensate discharge must always be present and changes must never be implemented regarding the condensate discharge.

### **1.3.6 Danger of fire or becoming trapped**

If you want to connect the appliance without ductwork, you must:

- Install a vent on the suction opening that impedes access to the fan compartment;
- Install a vent or blow plenum on the blow hole so that there is no direct access to the heat exchanger compartment. This vent or plenum must also ensure that flammable material cannot fall on the heat exchanger.

These accessories are available from our range. If you do not know which accessories you need, you can contact your dealer for additional information.

- Also make absolutely sure that the environment in which the appliance is being installed cannot lead to any dangers because of floating dust and/or flammable or corrosive substances or fumes.

Some parts of the appliance can become very hot during and shortly after use.

- Only carry out activities such as maintenance after the appliance has completely cooled down.

### **1.3.7 Risk of corrosion damage**

Chemical products such as solvents, paints, adhesives, soaps, etc., may lead to corrosion in the air heater or in the CAS/FGO.

- Ensure that the combustion air is always dust-free and is not polluted by fluorine, chlorine, sulphur and other contaminants.
- If the combustion air is being supplied through a chimney duct, it must not have been used in the past as an FGO for fuel oil devices, coal or wood burners or open fireplaces.
- If the appliance is set up in laundrettes, ironing parlours, swimming pool rooms, etc., the appliance must be installed in a separate set-up room in which the ambient air is free from chemical contaminants.
- Combustion air that is insufficiently dust-free can lead to an unreliable ignition and, in extreme cases, even damage to the heat exchanger because of internal dirt. If this risk exists, you must order an intake filter for the CAS that is available as an accessory.

### **1.3.8 Material damage because of unsuitable tools**

In addition to conventional tools, you also need a number of specific tools to work on or maintain the Udara appliance.

- You need a special square drill bit, size 2, to loosen the tapping screws.
- In addition, you need a set of Allen wrenches with a rounded side.
- Using a 0-10 Nm torque wrench is recommended.
- You must have a flue gas analysing device that can measure the following substances in the flue gases: NO<sub>x</sub> (nitrogen oxides), O<sub>2</sub> (residual oxygen) and CO (carbon monoxide). If your appliance cannot measure NO<sub>x</sub>, it is strictly prohibited to change the adjustment of the appliance or to perform a manual calibration.

### **1.3.9 Material damage because of frost**

If the appliance is not set up frost-free, the appliance can be damaged. If the temperature of the suctioned air drops far below freezing point, frost can even occur in the heat exchanger itself.

In such a case, a bypass must be made using the air outlet duct to the suction duct so that the suctioned air is preheated.

### **1.3.10 Material damage to the flexible gas tube**

The flexible gas tube can be damaged because of a heavy load due to a weight or repeated and unnecessary bending.

- Do not suspend the burner and mixing box from the flexible corrugated gas tube during maintenance

### **1.3.11 Material damage after water ingress**

If the appliance or parts of it are exposed to water ingress, the appliance must be put out of service immediately. All safety components that are exposed to water must, subsequently, be replaced

## 2 General information

### 2.1 Description

Multicalor Udara air heaters are gas-fired condensing and modulating appliances with a cleaner combustion, automatically controlled direct current fans and a gas-adaptive control.

### 2.2 Gas category

The appliance has been set for being fired with natural gas of the second family (I2N) ex-factory. If you want to use the appliance with propane, the burner management control system must be adjusted and a new nameplate must be added to the appliance. Only an engineer appointed by the manufacture can do this.

The appliance is delivered ready for use. It is sufficient to connect the flue gas outlet (FGO) duct, the combustion air supply (CAS) duct, the gas pipe, the condensate discharge, the air ducts and the power lines.

### 2.3 Standard version

The standard version of the appliance is used for the distribution of recycled air to which no more than 25% of outdoor air is added or for the distribution of outdoor air to heat recovery. The appliance will work in this mode ex-factory.

### 2.4 Outdoor air version

The outdoor air version of the appliance is used to distribute air to which more than 25% of outdoor air is added.



#### **Warning!**

If the appliance is deployed as an outdoor air version, you must perform the changes specified below to prevent damaging the appliance.

If you want to deploy the appliance as an outdoor air appliance, you must order an additional insulation set to insulate the fan compartment of the Udara air heater. This will limit condensation on the outer housing of the appliance.

In addition, the condensate trap must be installed outside the appliance using an extended hose set with regard to the upflow versions of the Udara.

The condensate hoses in the fan compartment must also be safeguarded from frost, for example, by installing thermal insulation and/or a heating ribbon around the hoses.

If the temperature of the suctioned air drops below freezing point, the condensate in the heat exchanger itself can freeze. In such a case, a bypass must be made using the air outlet duct to the suction duct so that the suctioned air is preheated. 2

### 2.5 Versions

The Multicalor Udara appliances are available in 2 versions: upflow and downflow.

#### 2.5.1 Upflow

Suctioning takes place at the bottom of the appliance with regard to an upflow version. The blowing out of the hot air takes place at the top of the appliance. This is also sometimes called a top blowing version.

The filter is at the bottom of the air heater as standard. If you want to connect the appliance on its side, you must order an optional filter frame.

If side connection is required, we recommend ordering a long tool life filter from the accessory range and not to opt for the standard side filter frame with regard to the Udara 40 and 50.

#### 2.5.2 Downflow

Suctioning takes place at the top of the appliance with regard to a downflow appliance. The blowing out of the hot air takes place at the bottom of the appliance. This is also sometimes called a bottom blowing version.

DF is added to the appliance type with regard to the downflow version.

## 3 Technical data

### 3.1 In general

Udara air heaters are CE approved by Certigaz SAS and comply with the EU 2016/426 gas directive. The CE label, affixed in each appliance, is the guarantee that the appliances are under constant CERTIGAS control.

### 3.2 Technical data

#### 3.2.1 Gas category I2N and I3P technical data

Udara HR (DF)			10	15	20	30	40	50
Gas category			I2H, I2L, I2N, I2E, I3P					
Gas appliance types			B22p, C12, C32, C52, C92					
Maximum load on the lower value [PCI]	G20 - 20 mbar	kW	10.0	14.8	19.7	29.5	39.4	49.2
Minimum load on the lower value [PCI]	G20 - 20 mbar	kW	1.8	2.6	3.4	5.1	6.8	8.6
Maximum power	G20 - 20 mbar	kW	10.6	15.7	21.0	31.4	42.1	52.5
Minimum power	G20 - 20 mbar	kW	2.0	2.8	3.7	5.6	7.4	9.4
Gas consumption at full load	G20 - 20 mbar	m <sup>3</sup> /h	1.058	1.566	2.085	3.122	4.169	5.206
Gas consumption at partial load	G20 - 20 mbar	m <sup>3</sup> /h	0.190	0.275	0.360	0.540	0.720	0.910
Gas consumption at full load	G25 - 25 mbar	m <sup>3</sup> /h	1.253	1.854	2.468	3.695	4.935	6.163
Gas consumption at partial load	G25 - 25 mbar	m <sup>3</sup> /h	0.216	0.313	0.409	0.614	0.818	1.035
Thermal efficiency at full load		%	106.2	106.3	106.4	106.6	106.8	106.8
Thermal efficiency at partial load		%	109.0	109.0	109.0	109.0	109.0	109.0
NOx emissions			< 30 mg / kWh (CLASS 5 EN1020 / EN1319)					
Gas category			I3P					
Maximum load on the lower value [PCI]	G31 - 37 mbar	kW	10.2	15.1	20.1	30.1	40.2	50.2
Minimum load on the lower value [PCI]	G31 - 37 mbar	kW	1.7	2.4	3.2	4.8	6.3	8.0
Maximum power	G31 - 37 mbar	kW	10.5	15.6	20.7	31.1	41.6	52.0
Minimum power	G31 - 37 mbar	kW	1.8	2.6	3.4	5.0	6.7	8.5
Gas consumption at full load	G31 - 37 mbar	kW	0.417	0.617	0.822	1.231	1.644	2.053
Gas consumption at partial load	G31 - 37 mbar	kW	0.069	0.099	0.13	0.195	0.260	0.328
Inlet pressure	G20	mbar	20					
	G25		25					
	G31		37					
Nominal air flow rate		m <sup>3</sup> /h	650	1200	1500	2100	3000	3500
Nominal temperature increase		°C	51	41	44	47	44	47
Maximum discharge air temperature		°C	80					
Working temperature in heating mode		°C	minimale 0° / maximale 35°					
Nominal taken up power		kW	0.17	0.20	0.26	0.30	0.55	0.60
Diameter restriction		mm	3.6	4.0	4.0	4.4	6.0	6.4
Mixing box		#	45	45	30	30	10	0
Venturi		#	4	4	5	8	6	6
Gas connection		Ø	1/2" G					
FGO diameter		mm	80					
CAS diameter		mm	80					
Protection degree		IP	20					
Condensate discharge diameter		mm	32					
Condensate quantity		kg/h	1.3	2.0	2.6	3.9	5.2	6.5
Power supply voltage		V	230 V - 50 Hz (N + L + PE)					
Width		mm	400	400	400	500	600	700
Depth		mm	720					
Height		mm	1100					
Weight		kg	52	66	71	84	99	122
Fuse (outside appliance)		A	6T	8T	8T	16T	16T	16T
CE approval number		#	1312DO6801					

### 3.3 Overview of components

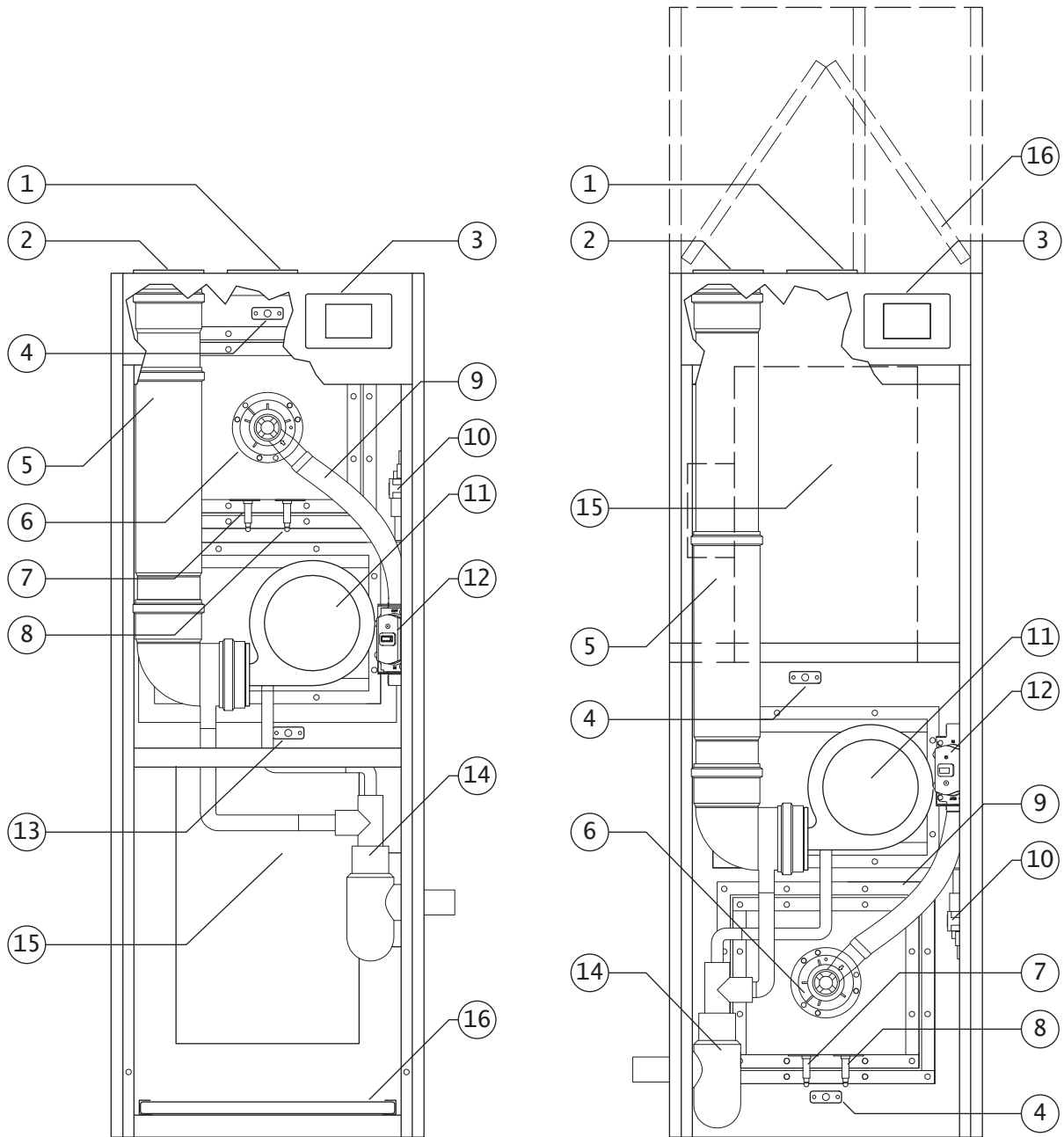

#### Legend

Number	Meaning
1	Combustion air supply
2	Flue gas outlet
3	Control panel
4	Probe discharge air temperature (NTC 2 / NTC 5)
5	Flue gas outlet coupling
6	Mixing box and venturi
7	Ionisation electrode
8	Ignition electrode
9	Flexible gas tube
10	Burner management control system
11	Flue gas fan
12	Gas valve
13	Intake temperature probe (NTC 1)
14	Condensate discharge trap
15	System fan
16	Air filter (in downflow in filter cabinet)

### 3.4 Dimensions

#### 3.4.1 Dimensions Upflow

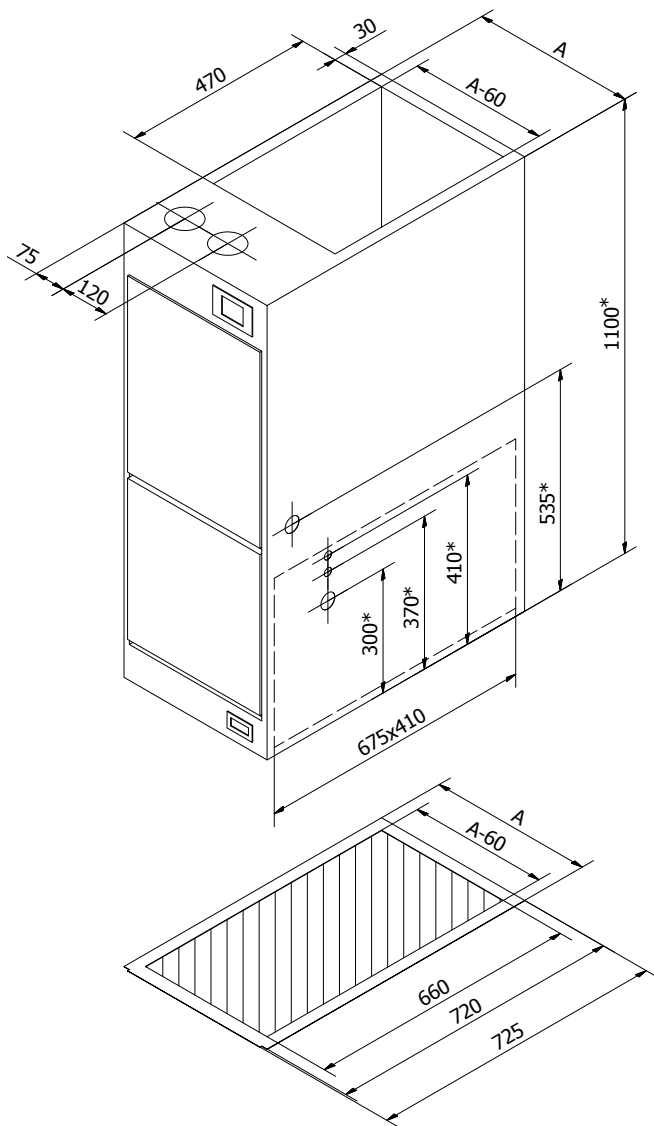

#### Legend

Udara	10	15	20	30	40	50
A		400		500	600	700
*						+ 70
a	Gas throughput					
b	Power supply cable connection					
c	Thermostat connection					
d	Condensate drain throughput					

#### 3.4.1 Dimensions Downflow

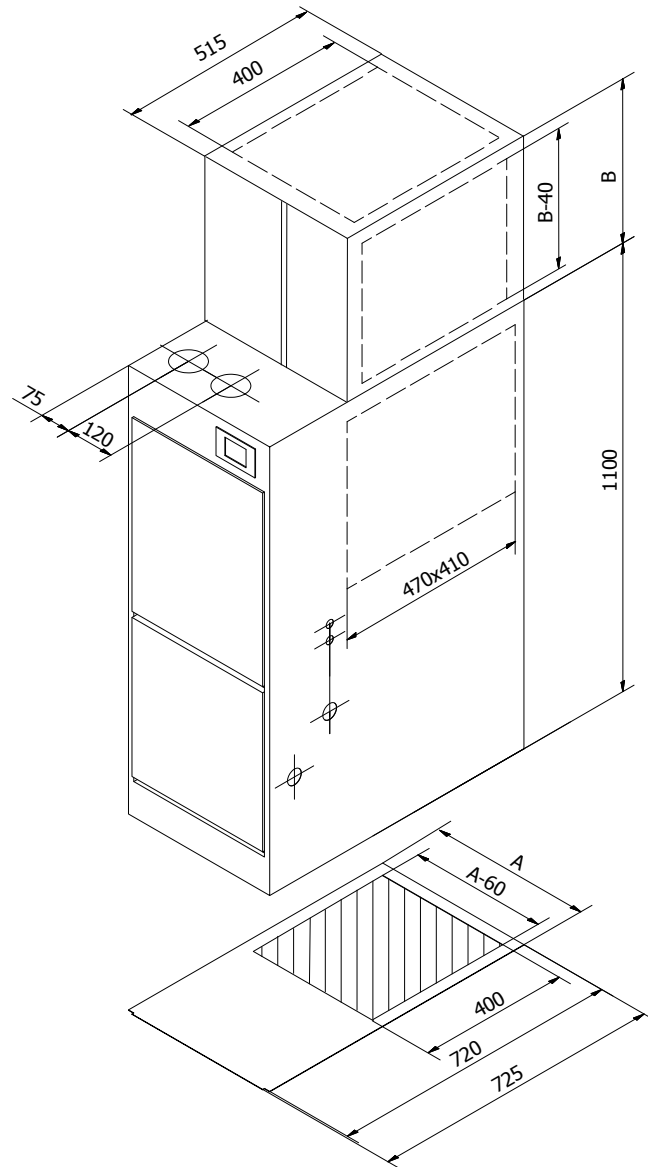

#### Legend

Udara	10	15	20	30	40	50
A		400		500	600	700
B		340		440	540	540
*						+ 70
a	Gas throughput					
b	Power supply cable connection					
c	Thermostat connection					
d	Condensate drain throughput					

# 4 Installation

## 4.1 In general



### Danger!

Before installing or commissioning the appliance:

- Make sure that the conditions of the local distribution mains (gas and power) match the adjustment of the appliance.
- Check whether the country of destination is specified on the packaging and the nameplate matches the country where you are installing the appliance (BE = Belgium).
- Check whether the selected CAS/FGO method is specified on the nameplate.

Contact us if this is not the case and immediately stop the installation or commissioning.



### Warning!

The air heater must only be installed by a competent installer who has all the legally required certificates.



### Local standards

The installation must be performed in accordance with the latest publication of all local standards and the installation manual of the appliance.

Ensure you consult the NBN B 61-001, NBN B 61-002, NBN D 51-003, NBN D 51-004, NBN D 51-006, NBN D 30-003.

### 4.1.1 Damage during transport

Check the air heater for damage during transport upon delivery. If damage is established, specify this on the consignment note and warn your supplier in writing.

### 4.1.2 Packaging

The air heaters are packaged in a box made of recycled cardboard. Do not throw away the packaging, but again offer it for recycling.

### 4.1.3 Minimum free space around the appliance

Ensure that the following minimum free space is available when setting up the appliance:

- keep 50 mm free around the appliance;
- keep at least 25 mm free space around the flue gas outlet and possible flammable material; free space is not required with regard to a concentric flue gas outlet;
- approximately 1000 mm of service space must be available at the front side of the appliance (ensure that there is a comfortable standing height);
- at least 200 mm of free space must be available on the side of the condensate discharge.

### 4.1.4 Set-up room

Pay attention to the following guidelines when determining the place to set up the air heater:

- Position the appliance as closely as possible to the flue gas outlet and the combustion air ducts.

- Position the appliance centrally in comparison to the ductwork.
- Position the appliance on a level and robust substrate.
- The appliance must be raised on a wet floor.
- Always set up the appliance isolated from the structural structure to prevent the transmission of noise and vibrations.



### Danger!

- When using an open return, no appliances with an open combustion chamber may be present in the same set-up room. Strictly respect local standards with regard to the ventilation of the set-up room.



### Attention!

The appliance must be level!  
The appliance must be set up frost-free.

### 4.1.5 Moving the appliance on site

The air heaters must never be moved using the corners by tilting the appliance. The housing of the appliance can be irrevocably damaged due to this. This damage is not covered by the appliance's guarantee.

## 4.2 Installation of the flue gas outlet system



### Danger!

- Protect the flue gas outlet with a non-flammable sheath if it is being guided through walls or cavities made of flammable material. Always respect the free space of 25 mm between this sheath and the discharge pipe.
- Every Udara appliance must be equipped with an individual FGO/CAS. Shared discharge systems are not permitted.
- The burner compartment of the Udara is part of the combustion circuit. The appliance must not be put into operation with a missing front cover.



### Information(s)

In some countries, the use of CAS or FGO pipes that have not been enclosed in metal or other fire-retardant material is prohibited. Always consult the local standards before installing.

Udara air heaters are appliances that, by preference, are set up as a closed appliance (type C). This means that the appliance must be connected through a parallel or concentric flue gas outlet (FGO) and combustion air supply (CAS).

Combustion gases are discharged through one pipe and air required for the combustion is supplied through the other pipe.

You can also set up the appliance as an open one (type B). If the appliance is set up as B22p, a special air filter must be installed on the suction inlet of the Udara air heater. This filter will stop the igniter ducts between the premix burners from becoming obstructed and will prevent individual objects from falling into the appliance.

Always position measuring points in the FGO and CAS so that a representative sample of the flue gases and the combustion air can be taken. The measuring points must, by preference, be positioned as close as possible to the appliance.

The used CAS and FGO pipes must be gas-tight and must meet the applicable standards. Multicalor has PP and stainless steel pipes in its range that meet all applicable standards. If the discharge of the combustion gases and supply of combustion air takes place through the roof, the especially designed and approved icicle-low roof gland MUGRO SKYLINE must be used.

Les conduites utilisées pour l'évacuation des gaz de fumée et l'alimentation en air de combustion doivent être étanches aux gaz et respecter les normes en vigueur. Dans sa gamme, Multicalor possède des conduites en PP et en inox qui respectent toutes les normes en vigueur.

Connecting to another roof gland is not permitted in relation to the approval in accordance with the Gas Appliance Directive. If the discharge of combustion gases and the supply of combustion air takes place through the wall, the especially designed and approved wall gland MUGRO WALL must be used. Connecting to another wall gland is not permitted in relation to the approval in accordance with the Gas Appliance Directive.

The flue gas outlet must be installed with a minimum slope of 5 cm/m towards the appliance so that the condensate can flow towards the appliance.

#### 4.2.1 Type B22p connection

The combustion air is taken from the room with regard to a type B22p connection. The discharge takes place through a gas-tight fixed or flexible pipe.

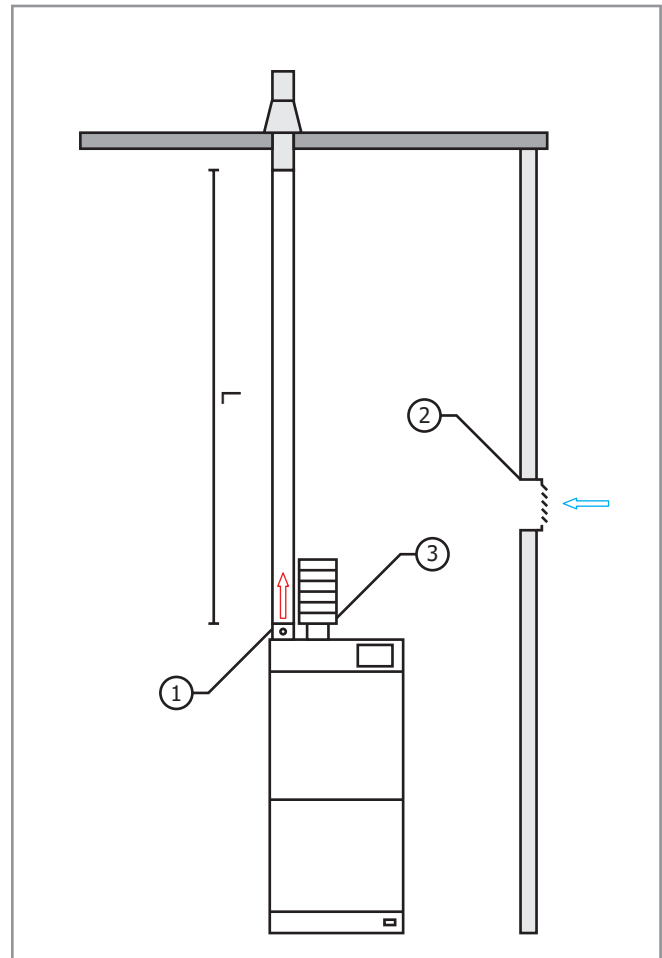

#### Legend

Number	Meaning
1	Measuring point
2	Combustion air supply opening
3	Intake filter (dusty rooms) or protective vent

There must always be a direct and non-closable air supply outlet towards the outside with an area of 3 cm<sup>2</sup>/kW as the total set up power with a minimum of 150 cm<sup>2</sup>. If local standards prescribe stricter requirements, you must, of course, comply with these. Position a protective vent or, when setting up the appliance in dusty rooms, an intake filter on the CAS so that no individual objects can fall into the appliance and the burner is safeguarded from contaminants. Always position a measuring point in the FGO. The maximum allowable length for the discharge pipe is specified in table 4.2.7.



#### Danger!

Never connect an Udara appliance straight on to a standard chimney! A gas-tight FGO must always be used.

#### 4.2.2 C52 two-pipe system

As an alternative to open flue gas outlet system B22p, you can also use closed system C52.

The drawing below shows a two-pipe C52 system.

The length of the flue gas outlet ( $L1+L2+L3$ ) plus the equivalent length of the bends must not exceed the maximum value specified in item 4.2.7.

Always install a measuring point in the CAS and FGO.

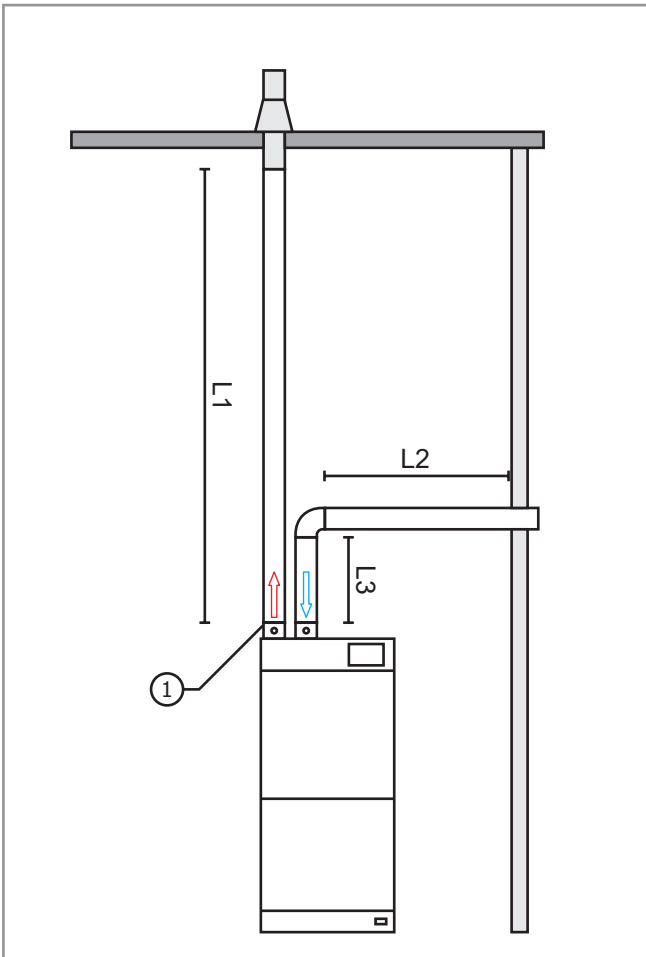

#### Legend

Number	Meaning
1	Measuring point

#### 4.2.3 Parallel systems (C12/C32)

You can use a parallel system to discharge the flue gases. Multicalor carries a range of supply and discharge pipes made of high-quality PP and stainless steel.

The drawing below shows a parallel system.

The length of the flue gas outlet plus the equivalent length of the bends must not exceed the maximum value specified in item 4.2.7.

Always install a measuring point in the CAS and FGO.

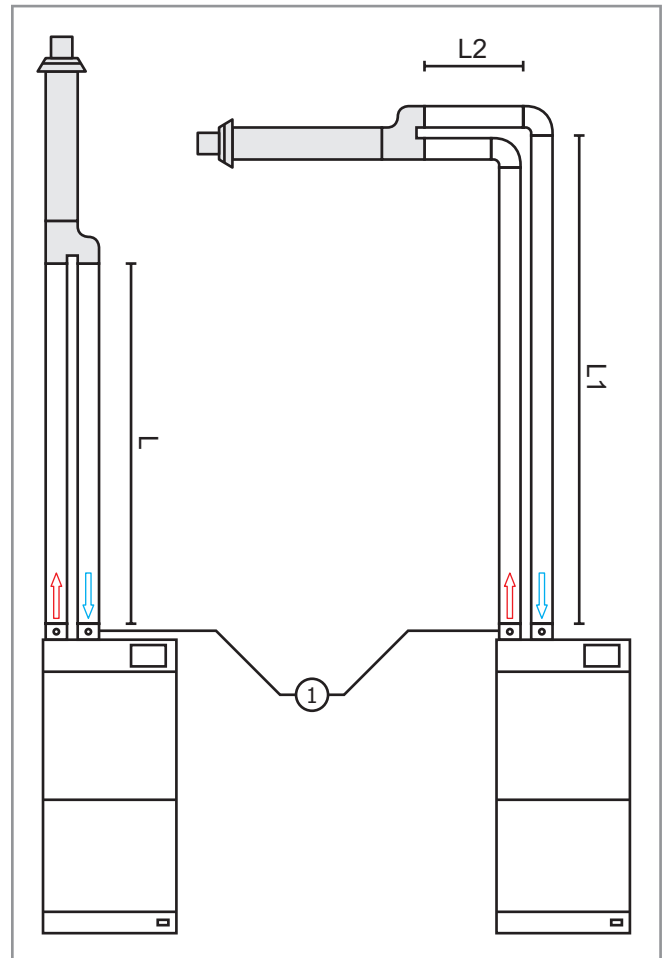

#### Legend

Number	Meaning
1	Measuring point

#### 4.2.4 Concentric systems (C12/C32)

The flue gas outlet (FGO) pipe is surrounded by the combustion air supply (CAS) pipe with regard to a concentric flue gas outlet system. Multicalor carries a full range of concentric pipes.

The Y-pipe supplied with the flue gas outlet terminal must be positioned on top of the appliance with regard to a concentric connection.

Always position a measuring point in the concentric piping, by preference, immediately after the Y-pipe or, if this is not possible, as close as possible to the appliance.

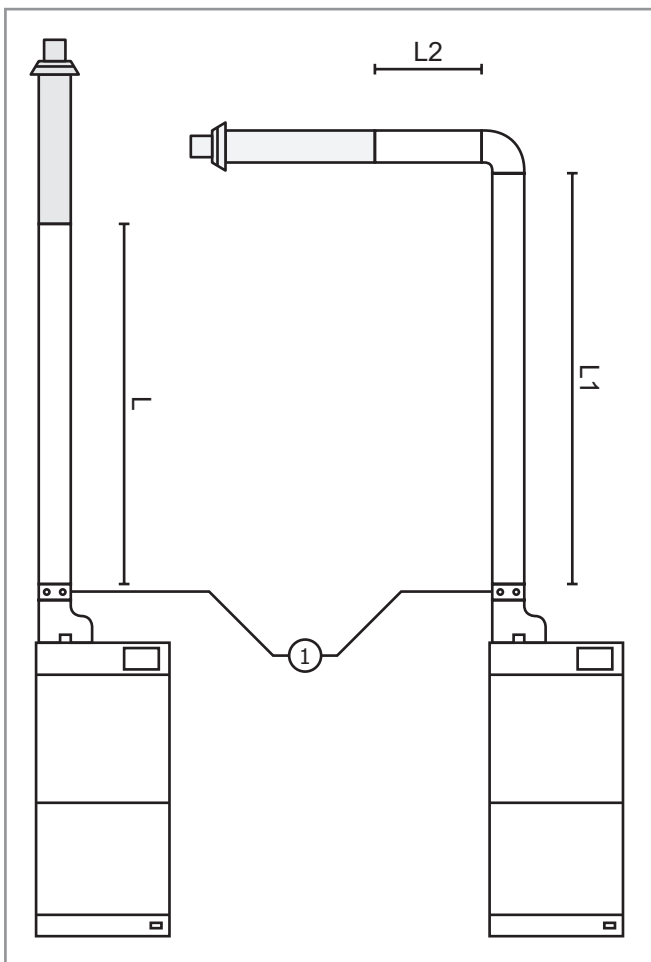

#### Legend

Number	Meaning
1	Measuring point

The length of the flue gas outlet plus the equivalent length of the bends must not exceed the maximum value specified in item 4.2.7.

#### 4.2.5 Chimney renovation (C92)

It is sometimes interesting to install a special flexible flue gas outlet pipe with a diameter of 80 mm in an existing flue gas outlet (conventional) fireplace. The combustion air can then be supplied through the air cavity between the flue gas outlet pipe and the existing chimney or in the room itself. The connection between the flexible pipe in the old flue gas duct and the appliance can then take place in parallel or concentrically.

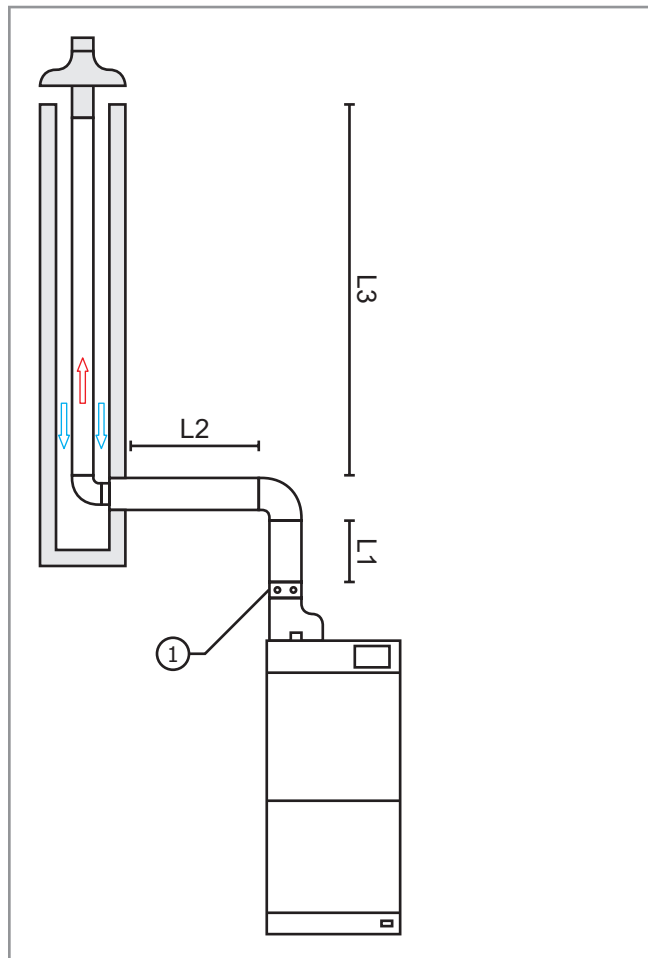

#### Legend

Number	Meaning
1	Measuring point

The length of the flue gas outlet plus the equivalent length of the bends must not exceed the maximum value specified in item 4.2.7.



#### Warning!

Do not use the old flues as combustion air supply if they have been used in the past as the FGO for fuel oil appliances, coal or wood burners or fireplaces.

If you want to use this system, the existing fireplace must at least measure 150 mm x 150 mm when using a discharge pipe with a diameter of 80 mm.

#### 4.2.6 Maximum length of the flue gas outlet



##### Warning!

The maximum allowed length of the flue gas outlet must not be exceeded.

The maximum length is the sum of the following: the length of the straight pipes (L, L1 + L2, or L1+L2+L3 in the figures)/ the equivalent length of the other elements such as bends or intake filters that you can find in the table below.

Depending on the used flue gas outlet and appliance types, the maximum length of the flue gas outlet and combustion air supply vary.

**Table 2: Maximum allowed length of the flue gas outlet**

Type	Ø	Remarks	Maximum allowed length					
			10	15	20	30	40	50
B22P	80 mm	Smooth pipes in PP/RVS	30	30	30	30	30	20
C52		Flexible pipes MG Flexline in the flue gas outlet						
C12	80/125	Concentric systems with wall terminal	12.5	12.5	12.5	12.5	12.5	10
C32	mm	Concentric systems with roof terminal						
C12	80 + 80	Parallel systems with wall terminal	20	20	20	20	20	15
C32	mm	Parallel systems with roof terminal						
C92	80/125	Concentric pipes dans la chaufferie	12.5	12.5	12.5	12.5	12.5	10
	mm	Flexible pipes MG Flexline in the flue gas outlet						
Bend 90°		Bend 90°			2.00			
Bend 45°		Bend 45°			1.00			
Bend 30°		Bend 30°			0.75			
Intake filter					4.00			
Protective vent					1.00			

#### 4.2.7 Allowed materials



##### Attention!

Never use flue gas outlet or combustion air supply piping made of PVC. Do not use aluminium for the flue gas outlet either.

You can use PP pipes as flue gas outlet pipes if local standards allow this. If not, use gas-tight pipes made of stainless steel of the 40, 50, 60 or 70 type in accordance with the EN 1856-1 standard.

You can use PP pipes as combustion air supply pipes if local standards allow this. If not, use gas-tight pipes made of stainless steel of the 40, 50, 60 or 70 type in accordance with the EN 1856-1 standard.

#### 4.2.8 Position of the terminal

All applicable standards must be respected with regard to wind attack and pollution. If local standards are not available, use the following guidelines:

- Every terminal must be located in a square of 0.6 m without obstacles.
- The distance between a roof terminal and a vertical wall must at least be 0.5 m.
- The distance between a roof terminal and a wall that makes an angle with it and in which windows can be found must at least be 2.5 m.
- The distance between 2 roof or wall terminals must at least be 0.6 m.
- The terminals of 2 end pieces that are one on top of the other in a wall must at least be 2.5 m
- Terminals may not be installed under a porch roof.
- The terminal must at least be at a distance of 1.0 m from the plot border.
- The wall terminal must at least be 1.0 m above ground level and the roof terminal must at least be 0.4 m above the roof (in connection with snow).
- The wall terminal must at least be at a distance of 0.5 m from the corner of the building.

### 4.3 Installation of the condensate drain



#### Warnings!

- NEVER shut off the condensate discharge.
- NEVER remove the trap and do not make any unauthorised changes to the condensate discharge.
- Do not discharge the condensate directly outside (frost risk), but discharge the water using the indoor drainage system.
- If local standards require condensate neutralisation, you must install such a device before discharging the condensate down the drain.
- The condensate drain **MUST** be installed with a slope (5 cm/m) towards the drainage system.
- The trap must be installed outside the fan compartment and hoses must be safeguarded from frost with regard to an outdoor air appliance.
- The trap must be installed outside the fan compartment and hoses must be safeguarded from frost with regard to an outdoor air appliance d'égout normal en PVC ou PE convient bien.
- The trap must be installed outside the fan compartment and hoses must be safeguarded from frost with regard to an outdoor air appliance
- After installation or maintenance, clean both traps and fill with clean water.

To ensure the appliance operates correctly, the condensate drain must be connected to the drainage system. The connection is provided on the right as standard. If required, the condensate drain can also be placed on the left. You must then move the blind grommet that seals the hole on the left side to the right side. If you move the trap to the left side, you may have to shorten the discharge hoses. You can do this with a sharp knife. Always connect the condensate drain in accordance with the enclosed drawing.

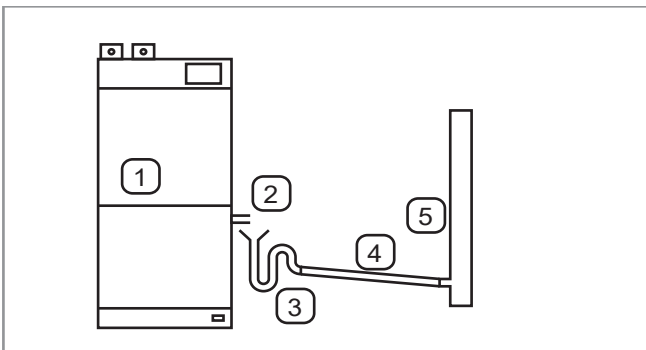

#### Legend

Number	Meaning
1	Appliance
2	Funnel
3	Extra trap
4	Gradient on slope (5 cm/m)
5	Indoor drainage

### 4.4 Installation of the gas pipe



#### Danger!

- The installation of the gas pipe must only be carried out by a certified installer or energy company.
- Check whether the gas category and inlet pressure match the data on the appliance's nameplate.
- Only use fittings and pipes that have been specifically approved for gas systems.
- Always consult local standards before installing the gas pipe.
- Always position an approved stop cock in front of the appliance. NEVER use a flame to check the piping or to trace a leak.



#### Attention!

- Ensure there is no dirt in the gas pipe. Purge the piping before installation using nitrogen to clean them.
- By preference, install an additional gas filter to prevent contamination of the gas control block.
- Pay attention when using leak sprays near electrical components.
- Close the stop cock and disconnect the gas valve when pressure testing the gas pipe. The maximum pressure when pressure testing is 125 mbar.

The area of the gas pipe must be in accordance with all applicable local standards and regulations. If the area is too small, the appliance will not be able to achieve its maximum power and starting problems can occur.

Connect the gas supply piping using a ½" connection directly on to a 90° bend that has been equipped with a gas control block ex-factory.

Position an approved shut-off valve immediately in front of the appliance. The feed for the gas connection is provided on the right as standard.

If required, the gas connection can also be on the left.

Blind grommets in the openings ensure there is an airtight seal of the burner compartment.



### **Danger!**

- Ensure that the installation is free from voltage (dead) before you start the installation.
- Always connect the earthing.
- Respect all applicable standards (for example, AREI (General Regulations on electrical installations)).
- Always position an external isolator switch at the appliance that will allow you to isolate the appliance from the mains.
- The minimum creepage distance between contacts must be 3 mm.

The electrical installation must always be carried out in accordance with the last publication of the relevant standards and the regulations of the local energy company.

#### **4.4.1 Connecting the power supply**

A 3-pole terminal has been installed in the fan compartment where a supplied plug can be installed for the mains power supply. A hole has been included in the housing to lead through the cable. Use the supplied blind grommet or cable coupling to lead through the cable.

Connect the cable to the 230 V~AC power supply with earthing.

We recommend connecting the appliance directly to the distribution box that has a delay fuse (the value to be used is specified in the technical data table).



### **Attention!**

We recommend using circuit breakers with a D switching-off curve because of the high input surge currents of the direct current motors.

You can also connect the cable using a plug to the wall socket outlet with a socket with safety earthing if required.

The Udara must always be supplied with power. If you temporarily put the appliance out of service, the appliance can be set to the standby mode using the RC21.

#### **4.4.2 Connecting the modulating thermostat**

The Udara is used, by preference, with the RC21 thermostat for simple residential applications.

A 2-pole terminal has been installed in the fan compartment on which a supplied plug for the thermostat can be installed.

A hole has also been included in the housing to lead through the cable. Connect the thermostat through a shielded and twisted 2-core signal cable with a wire cross-section of 2 x 0.8 mm<sup>2</sup>.

Install the room thermostat at an approximate height of 1.6 m centrally in the living room and easily accessible for the normal air circulation in the room. Always install the thermostat on an inside wall at a place where it will not be influenced by other sources of heat such as vents, electrical appliances, direct sunlight, etc.

We do not recommend installing next to windows, doors, close (< 1.20 m) to outside walls or under or close to a staircase either. For more information about installing and programming refer to the thermostat's manual.



### **Warning!**

Never connect a voltage-carrying room thermostat. The burner management control system will become irreparably damaged because of this.

## **4.5 Installation of the ductwork**

### **4.5.1 General remarks**



### **Danger!**

If you want to connect the appliance without ductwork, you must:

- install a vent on the suction inlet that stops the access to the fan compartment;
- install a vent or blow plenum on the blow hole so that there is no direct access to the heat exchanger compartment. This vent or plenum must also ensure that flammable material cannot fall on the heat exchanger.



### **Warning!**

Before you use the Udara upflow with readmission at the bottom, you must remove the bottom plate along the recesses.

Udara appliances have an air filter as standard. Never remove the air filter from an Udara appliance. The appliance must always be equipped with an air filter class EU3 or better.

#### **4.5.2 Installation of the supply ducts**

A range of white acoustic insulated air distribution boxes (plenums) are available for Udara appliances to which the supply ducts can be connected. The box is installed on top with regard to the upflow version and on the bottom of the appliance with regard to the downflow version.

More information is given in item 4.6.4 regarding the recommended minimum dimensions of the air distribution boxes to be used.

### 4.5.3 Installation of the readmission ducts



#### Attention!

Always install the readmission ducts in such a way that noise locks cannot occur between different rooms.

A range of white acoustic insulated air distribution boxes (plenums) are available for Udara appliances to which the readmission ducts can be connected. The box is installed at the bottom with regard to the upflow version and on top of the appliance with regard to the downflow version. The readmission ducts can also be connected directly on to the side of the air heater if required. Please order the optional filter cartridge for a side connection to do this.

The standard side filter frame for the Udara 40 and 50 is very small and we recommend using a long tool life filter from the range of accessories.

If you want to use an open return (only possible if there are no appliances with an open combustion circuit in the set-up room), you can order a perforated readmission plenum.

If you are connecting an outdoor air duct, a control valve must always be included in the outdoor air duct.

### 4.5.4 Air distribution box dimensions



#### Danger!

- Internal acoustic or thermal insulation in the air distribution box must be able to resist long-term increased temperatures and must be mechanically protected against being detached.
- The insulation must be erosion-proof so that no dust particles end up in the airflow.

Use the figures below as a guideline when determining the ideal size of the air distribution boxes and/or air ducts. Please contact us for advice if you have any doubts or questions.

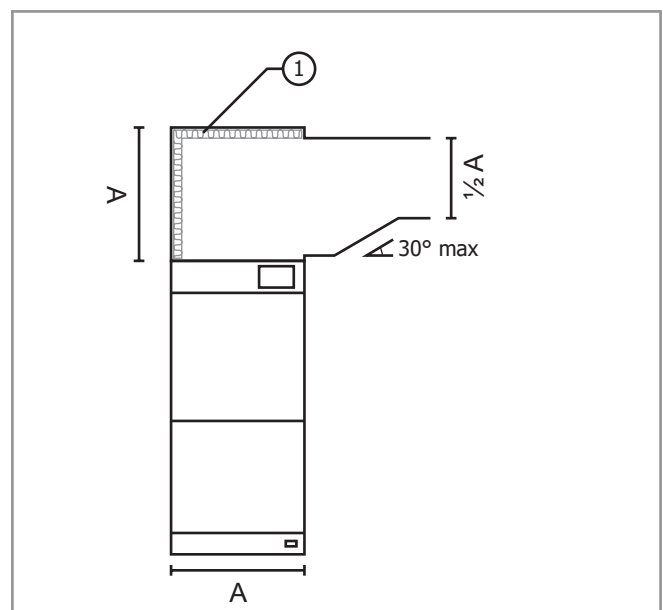
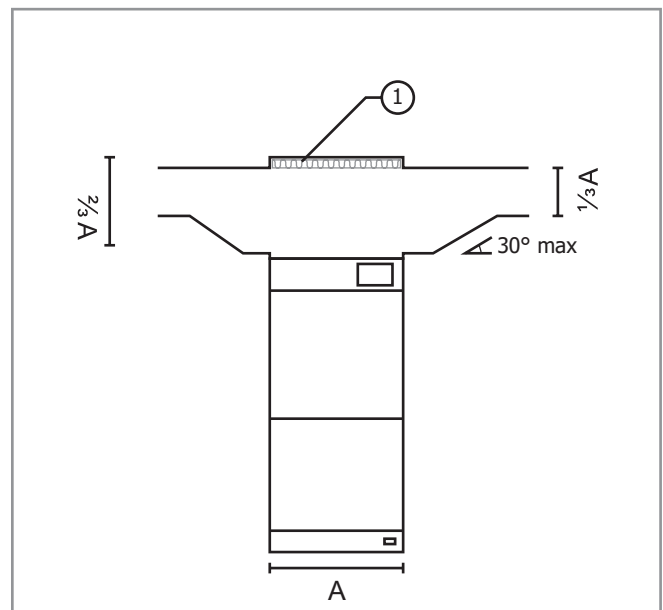

#### Legend

Number	Meaning
1	Acoustic and thermal insulation
A	Width of the appliance

# 5 Commissioning

## 5.1 Switching the appliance on and off

Normally, the appliance must always be supplied with power through the mains power supply. You can follow the following steps to switch the appliance on and off during installation or maintenance.

### 5.1.1 Switching on

Follow the following steps to switch on the appliance:

- Switch on the mains power supply.
- Open the gas valve.
- Set the room thermostat to the required value.
- After a short waiting time, the appliance will ignite.

If the lock-out symbol is displayed on the appliance screen or an error message is displayed on the RC21 thermostat, you must unlock the appliance by pressing the reset button. You can also unlock the appliance through the RC21.

You must thoroughly vent the gas pipe before starting the appliance with regard to a new installation. A poorly vented gas pipe can mean that the appliance will be in the error mode.

If the appliance does not ignite after repeated attempts and unlocking instances, consult the section about faults and failures or contact the manufacturer or installer.

### 5.1.2 Switching off

Follow the following steps to switch the appliance off:

- Set the room thermostat 5°C lower than the room temperature.
- Wait until the burner has switched off (the flame symbol will no longer be displayed on the screen).
- Close the gas valve.
- Wait until the appliance has fully cooled down (discharge air temperature < 30°C).
- Switch off the mains power supply.

## 5.2 Regulating the combustion

The combustion of the Udara has been set ex-factory and does not have to be changed normally. If, however, the burner management control system or the gas control block have been replaced, for example, after a fault, the calibration procedure must again be performed.

The simplest way in which to do this is through manual calibration using an RC21 thermostat. Having a device with which you can also measure the NO<sub>x</sub> (nitrogen oxide) content in the flue gases is recommended to ensure the procedure is performed correctly.

Enter the installer password to start the procedure; see the “Technical menu” page of the RC21. This password is issued when you follow training at Multicalor.

Next, select the “Calibration, manual complete” option. The appliance will attempt to start a few times until there is flame detection. When there is flame detection, the correct quantity of gas will be calculated

to achieve the best possible start behaviour. This value is stored in the burner management control system and cannot be changed by the installer. Next, the heater will start to burn at maximum power

The following will be displayed on the screen:

Boiler calibration	
Phase of procedure:	max...
Combustion set:	50
Power level:	100%
Boiler temp:	75°C
Error:	none
Cancel	Confirm



### Attention!

Ensure that sufficient vents have been opened so that the appliance can get rid of its power. If you do not do so, the overheat control will be activated and the calibration will be interrupted.

If the flame signal is stable, “Max ok” will be displayed on the screen. Next, you can change the CO<sub>2</sub> in the combustion gases by changing the “Combustion set” value. If you increase the value, you decrease the CO<sub>2</sub>. If you decrease the value, you increase the CO<sub>2</sub>.

Boiler calibration	
Phase of procedure:	max ok
Combustion set:	◀ 50 ▶
Power level:	100%
Boiler temp:	75°C
Error:	none
Cancel	Confirm

If you, next, confirm the setting by pressing “Confirm”, the controller will continue to the next step.

Next, a combustion test will be performed at approximately 60% of the maximum power.

Boiler calibration	
Phase of procedure:	med...
Combustion set:	55
Power level:	60%
Boiler temp:	55°C
Error:	none
Cancel	Confirm

The working method here is analogous to the previous step. The controller will complete a number of tests and, next, "Med ok" will be displayed on the screen if the combustion is stable. Here you can also change the CO<sub>2</sub> in the combustion gases by changing the "Combustion set" value. After pressing "Confirm", the appliance will also be tested on low power. If you again confirm this test by pressing "Confirm", the new settings will be stored in the burner management control system.

The normal setting can be read from the table below:

**Normal settings I2N**

Fase	CS (typ)	CS Max	CS Min	CO <sub>2</sub> ±0.5%	NOx ±10 ppm	CO ±10 ppm
Max	50	70	30	8.5	20	< 10 ppm
Med	55	70	35	8.5	20	< 10 ppm
Min	90	120	70	8.5	10	< 50 ppm

**Normal settings I3P**

Fase	CS (typ)	CS Max	CS Min	CO <sub>2</sub> ±0.5%	NOx ±10 ppm	CO ±10 ppm
Max	50	70	30	9.6	20	< 10 ppm
Med	55	70	35	9.6	20	< 10 ppm
Min	90	120	70	9.5	10	< 50 ppm



**Warning!**

- Most flue gas analysing devices measure the residual oxygen in the flue gases and calculate the CO<sub>2</sub> based on this value. The Udara works in a vacuum (flue gas fan after the combustion chamber) and, therefore, leaks in the combustion circuit (for example, an empty condensate trap) will lead to a dilution of the flue gases and an incorrectly measured value. Only change the adjustment if you are sure that the combustion circuit is airtight.
- The integrity of the combustion circuit can be easily established by measuring the concentration of nitrogen oxides (NOx) in the flue gases. When the CO<sub>2</sub> content is 8.5, the NOx content is approximately 20 ppm (I2N). When the CO<sub>2</sub> content is 9.6, the NOx content is approximately 20 ppm (I3P)

**5.3 Converting the appliance to propane**



**Danger!**

- The Udara must only be converted to propane in Belgium by an engineer appointed by the manufacturer because a new nameplate (with another gas category) must be added to the appliance.
- Never use butane (I3B) as the gas type.

The Udara can be very easily converted to be used with liquid gas (propane I3P).

It is sufficient to set the parameter TSP 9 to the value 1 and, next, perform a new calibration.

In Belgium, this conversion must be carried out by an engineer appointed by the manufacturer because a new nameplate must be added to the appliance.

# 6 Operating and setting

## 6.1 In general

Multicalor Udara air heaters are very advanced appliances where special attention has been paid to a minimum energy consumption.

The appliance is equipped with a unique patented heat exchanger made of stainless steel. The flue gases are cooled down to produce condensate in the heat exchanger. The additional heat that is released during this process increases the efficiency of the combustion to unprecedented levels.

In addition, the power based on electricity has been significantly reduced by using automatically controlled fans with direct current motors. Even when the motor speed is low, the efficiency will continue to be high so that it is better for the environment and your electric bill will be lower.

The advanced burner management control system is equipped with a gas-adaptive control. This means that the ratio between the combustion air and gas is set, monitored and, if required, adjusted electronically.

Thanks to this gas-adaptive control, you will always be assured the best combustion quality even when the gas quality is not constant.

The burner management control system monitors the gas/air ratio under all conditions and will always adjust this to achieve a safe and efficient combustion.

This extremely modern control technology also ensures that the gas/air ratio can be adjusted briefly so that the appliance also ignites reliably under ice cold conditions and after long periods of being idle.

Thanks to the gas-adaptive control, the Udara appliance can reduce its capacity in a steplessly variable manner to approximately 15% of the nominal power.

This offers the best comfort in combination with a modulating room thermostat: the difference between the required and the current room temperature is measured and, based on this, the optimum power is determined to heat up the room quickly or to keep it comfortably warm.

The air quantity will be adjusted automatically to the discharge air temperature so that a pleasant indoor climate and an extremely uniform temperature is obtained.

The installer can set a low, average or high air quantity. These air quantities are linked to a low, average or high air temperature. This ensures you can have high control over the blowing characteristics of the appliance

## 6.2 Modulating thermostat RC21

We recommend using a Multicalor RC21 timer thermostat to drive the appliance for simple household applications.

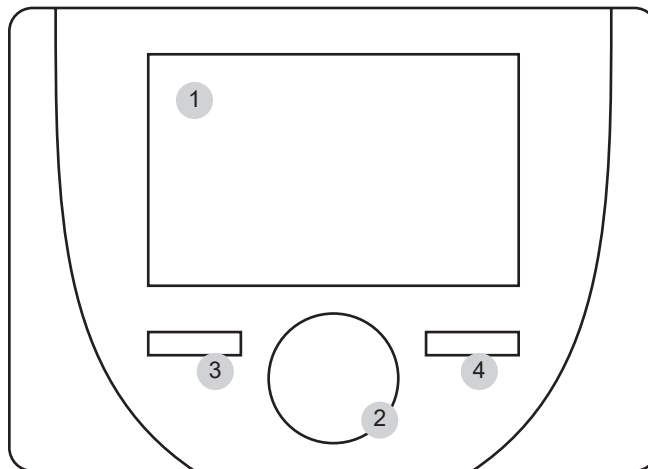

### Legend

Number	Meaning
1	RC21 thermostat LCD screen
2	Operating pressure button
3	Context button A
4	Context button B

This modulating thermostat exchanges data continuously with the burner management control system so that the good operation of the appliance, the modulation degree and other appliance data of the thermostat can be read.

The thermostat allows you to remotely start the fan. You can choose whether the fan is not operational or runs at a low, average or high speed (also see item 6.6).

The thermostat also allows you to unlock the appliance if a locking fault has occurred.

The thermostat must, by preference, be connected using a twisted and shielded 2-core cable. The polarity is not important.

Pour en savoir plus, référez-vous au manuel fourni avec le thermostat.

For more information refer to the manual that is supplied with the thermostat. For demanding applications such as, for example, connecting to a building management system, the control of different zones or connecting different appliances on 1 thermostat, the standard RC21 thermostat is not suitable.

If you need this additional functionality, you can opt for thermostats from the Multicalor Verventa range that must, however, be connected through a specially shielded bus cable of the following type: JY(ST)Y-MB 2X2X0.8 mm<sup>2</sup>. You can request more information about this from Multicalor.

### 6.3 Air-conditioning

You can expand the appliance with cooling. A cooling unit must then be installed outside and an evaporator must be installed inside on top of the Udara air heater.

This ensures that you can distribute cold air through the ducts during the summer months.

The RC21 thermostat can be used to switch on the cooling unit.

### 6.4 Heat pump

You can also expand the appliance with a heat pump. You can then use the heat pump to cool in the summer and to heat in the seasons in-between.

The gas burner will then only be used if the outside is colder and the efficiency of the heat pump becomes too low or if too many thawing cycles occur.

If you want to connect a heat pump, you must opt for a thermostat of the Multicalor Verventa range. For more information please contact us free from obligation.

### 6.5 Operation in heating mode

The operation of the air heater can be summarised as follows in normal use:

- If there is a heat demand, the appliance will ignite the burner. The fan will be started on a minimum air flow rate.
- The RC21 thermostat will measure the difference between the set and the current room temperature and will increase or decrease the air temperature based on this data.
- The air heater modulates the burner to achieve the set air temperature as best as it can.
- The system fan will adjust the air flow rate to the current discharge air temperature.

The air flow rates and air temperatures can be set by using the control panel.

### 6.6 Setting as ventilation

If required, you can set the fan in the appliance to a fixed air speed on the RC21, for example, during the summer months.

This can be considered as a set minimum flow rate, that is, the control can make the fan turn faster but never slower. You can select between 4 different settings.

#### 6.6.1 Ventilation off

The fan will only operate if there is a heat demand. If there is no heat demand, the fan will not be operational.

#### 6.6.2 Ventilation low

The fan will always operate at the set low air speed even if there is no heat demand.

#### 6.6.3 Ventilation average

The fan will always operate at the set average air speed even if there is no heat demand.

#### 6.6.4 Ventilation high

The fan will always operate at the set high air speed even if there is no heat demand.

### 6.7 The control panel

A control panel has been installed on the appliance to change the different settings of the appliance. The control panel is equipped with a capacitive touch screen and a TFT colour screen.



#### Attention!

- Try not to operate the screen using a sharp object or your fingernails.
- Only use your finger or a special pen suitable for capacitive touch screens.
- The screen responds to touch and not pressure. Pressing hard serves no purpose and can damage the screen.

#### 6.7.1 Basic screen

The following information is displayed on the screen as standard.

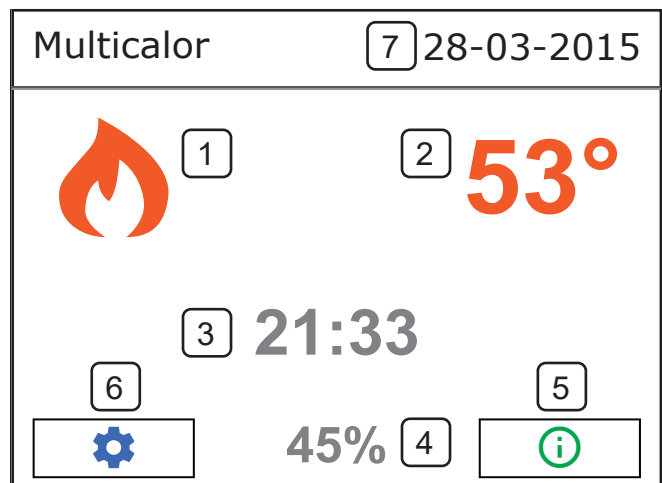

#### Legend

Number	Meaning
1	Function mode of the appliance
2	Air temperature
3	Time
4	Fan speed
5	Information menu button
6	Settings menu button
7	Date

### 6.7.2 Locking

If an error occurs that puts the safe operation of the appliance at risk, the appliance will be locked. The cause for locking the appliance is shown on the screen. The locking can be cancelled by pressing the unlock button. If the error, however, has not been resolved, the appliance will again be locked.

You must then contact your installer or the manufacturer for a solution.

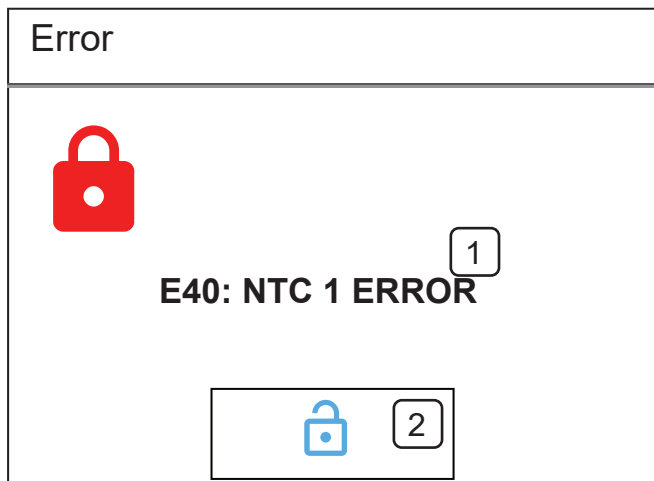

#### Legend

Number	Meaning
1	Error message
2	Unlock button

### 6.8 Changing settings

By pressing the setting icon , the first screen of the setting menu will be displayed

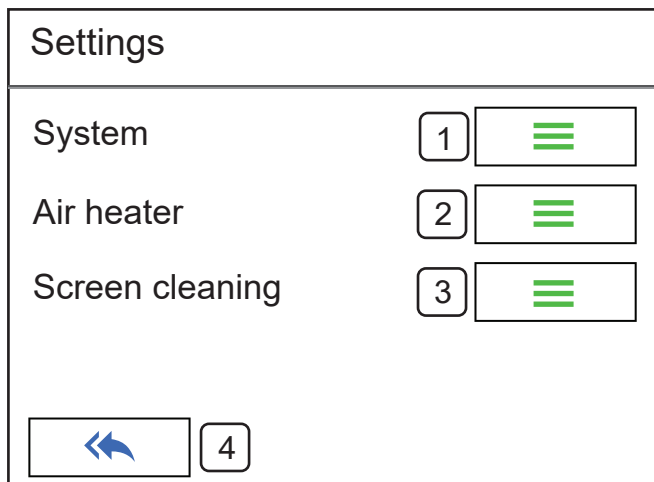

#### Legend



Number	Meaning
1	System settings
2	Settings in relation to the air heater operation
3	Screen cleaning
4	Back to the previous menu

A number of settings are discussed. Since all screens are accessible through the same process, not all screens will be discussed.

#### 6.8.1 Low, average and high temperature

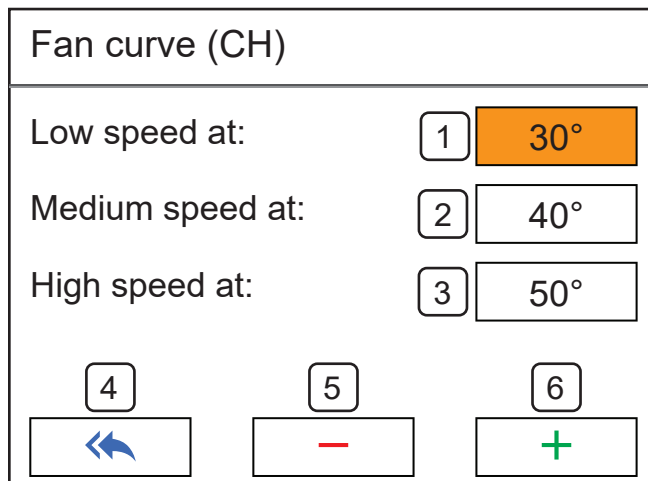
You can set 3 air temperatures on the Udara: a low, average or high value. To set these values, press the air heater (2) menu button, next, system fan and then the first fan curve option on the setting menu.



Next, select the value that you want to change. The selected value (1) will be displayed using an orange colour. By pressing the key  (5) or  (6), you can change the set value.

If you press  (4), les modifications sont sauvegardées automatiquement et vous quittez l'écran du menu.

#### 6.8.2 Low, average and high air speed

On the Udara, 3 air speeds can be set for heating: a low, average or high value. To set these values, press the air heater (2) menu button, next, system fan and, as last, the air flow rate.

Air flow (CH)		
Low:	1 10%	
Medium:	2 50%	
High:	3 80%	
4	5	6
←←	-	+

Next, select the value that you want to change. The selected value (for example, 3) will be displayed using an orange colour. By pressing the keys + (6) or - (5), you can change the set value.

If you press ←← (4), the changes are automatically saved and you will exit the menu screen.

### 6.8.3 Relationship between the air temperature and air speed, fan curve

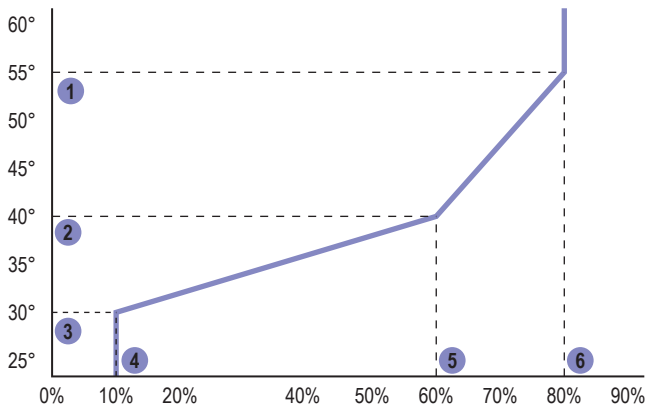

The relationship between the air temperature and air speed is displayed in the above graph. If the air temperature is lower than the “low value” (3) parameter, the fan is operational at the “low” (4) speed. If the air temperature is higher than the “high value” (1) parameter, the fan is operational at the “high” (6) speed. In-between these values, the speed of the fan is automatically adjusted based on the air temperature.

The “average value” (5) and “average” (2) parameters serve as an additional checking point to ensure you have more control over the air flow rate.

### 6.8.4 Setting the language

The control can be set to different languages. To access this setting, press the “system” (1) button in the setting menu and, next, the third option: Language.

Language		
English		
4	5	6
←←	-	+

Next, you can set the required language with the + (6) or - (5).

### 6.8.5 Setting the time and date

The time and date can be set similarly (not applicable when using the RC21 thermostat).

### 6.8.6 Screen cleaning

The touch screen can be temporarily switched off for cleaning by pressing the clean screen button. Clean the screen using a microfibre cloth or with a paper tissue.

### 6.8.7 Installer’s menu

Specific parameters can be found on an installer’s menu to stop thoughtless changes. This installer’s menu can only be accessed if a password (a code) is entered.

#### Installer code

Code	User level
123456	Power user
007007	Installer

The code for the “engineer” user level is only released after following training at Multicalor.



#### Warning!

Improper changes of the installer parameters can lead to damage to the appliance or that it no longer works as it should.

Changes do not normally have to be implemented in this menu.

### 6.8.8 Information screens

A number of parameters can be read by pressing the information button on the main menu. The information in these screen can only be read. The parameters cannot be changed. Provisionally, these screens only contain the version number of the operating software.

## 6.9 Error codes

If the appliance is in an unsafe situation, the control will be locked. Next, you must unlock the appliance by pressing the reset button (see item 6.4.2).

The following table lists the most frequent codes that will lead to the appliance being locked. If a specific error returns regularly, ask for advice from the installer or manufacturer.

Error	Meaning
E133	No ignition
E134	Gas valve open - no gas flow
E135	Internal error
E110	Safety thermostat open
E128	Flame signal lost 12 x
E129	Flame signal lost 12 x, max. gas control block current
E130	Flue gas temperature too high
E164	Flame signal wrongly present
E09	Gas valve error
E15	Gas valve error
E19	Discharge air temperature too high (TSP #2)
E19	Intake temperature too high (TSP #4)
E28	NTC 4 faulty (flue gas)
E20	NTC 2 faulty (air temperature)
E05	NTC 5 problem (air temperature/overheat control)
E21	NTC 5 faulty (air temperature/overheat control)
E22	NTC 5 / NTC 2 deviation too large
E23	NTC 3 faulty (optional - discharge air temperature)
E40	NTC 1 fault (intake temperature)
E10	NTC outdoor temperature fault
E160	Problem with flue gas fan
E53	Problem with flue gas outlet
E83	No communication with thermostat
E98	Internal error
E71	Fan outside range in calibration mode
E72	Poor combustion in calibration mode
E162	Incorrect frequency
E79	Control current of the gas valve too high
E78	Control current of the gas control block too low
E55	Calibration not performed
E165	Voltage too low
E77	Control current of the gas control block outside the operational area

The following error codes do not lead to a locking fault, but are saved in the burner management control system for a possible later analysis by a certified engineer.

Error	Meaning
E62	Flame unstable (wind) on low power
E63	Combustion quality outside operational area
E65	Speed limit of the combustion correction exceeded
E66	Obstruction in the FGO on minimum power
E67	Flame unstable (wind) on high power
E69	Combustion unstable during self-test
E70	Flame power signal problem
E73	Flame power signal active
E77	Control current of the gas control block outside the operational area

## 7.1 Maintenance by the user

### 7.1.1 Cleaning the air filter

The standard air filter is a plastic air filter. The air filter has a service life of approximately 1 year. The filter must also be cleaned every month. Follow the following steps to clean the filter:

- Set the thermostat 5°C lower than the ambient temperature.
- Set the fan position to OFF if this is not yet the case.
- Remove the air filter and clean it by using a vacuum cleaner. Only clean the dirty side.
- Position the filter back in the appliance.
- Reset the room thermostat at the required value.



#### Attention!

- Never remove the air filter from an Udara appliance. The appliance must always have an air filter class EU3 or better.
- If you clean the filter with a vacuum cleaner, only clean the dirty side.
- Always install the filter in the same way (in other words, with the clean side towards the fan) and do not turn it around.

### 7.1.2 Cleaning the housing

The housing can be cleaned with a soft moist cloth. Do not use aggressive agents such as bleach, solvents or petrol. This can damage the paintwork.

## 7.2 Maintenance by the installer

The appliance should, by preference, be maintained by the installer every year. Follow the following steps to maintain the appliance.

1. First check whether the set-up room is safe. There must not be any flammable substances and the ventilation must also be in accordance with the standards.
2. Set the room thermostat 5°C lower than the ambient temperature (allow the appliance to cool down).
3. Shut off the power and gas supply.
4. First remove the filter panel. Next, remove the 2 screws that keep the fan cover in place. Next, remove the fan cover by lifting it and tilting it forwards. Next, you can loosen the two screws that hold the front panel. This will give you access to the burner compartment.
5. Check the condensate discharge system for leaks. Remove the discharge system of the condensate if required and seal/repair missing seals.
6. Visually check the components in the appliance for damage.
7. Check the mixing box for dirt. Remove the protection shut-off valve if required and clean the mixing box using compressed air. In this case, also clean the rear side of the burner. Ensure that the igniter ducts are not obstructed and dirty.

Note: only clean the burner using compressed air. The burner must never be brushed. Make sure that the heat shield in the burner does not fall out of the housing if you disassemble the entire burner.

8. Check the gaskets of the mixing chamber and combustion chamber. These gaskets must be replaced every two years or if they are damaged. If the gaskets are damaged, irreparable damage may result.
9. Check the flue gas outlet and the combustion air supply for leaks and dirt.
10. Clean both traps. After cleaning, reinstall and fill with clean water.
11. Install the components in the reverse sequence, vent the gas pipe thoroughly and again switch on the mains power supply.
12. Check the gas pipe for leaks.
13. If the control is released, allow the appliance to start and, next, generate 100% heat demand using the thermostat. Ensure that the appliance can deliver the appropriate flow rate because, if not, the appliance will modulate back. Measure the combustion values and enter them in the appliance firing report. If the flue gases are hotter than 50°C, check whether there is a problem with the system fan. It is also possible that the load is too high.
14. If the appliance does not start properly, check the combustion. Consult item 5.2 for more information if required. If the combustion is correct, but starting problems occur anyway, you must disassemble the burner and check the distance between the ignition electrodes and the distance from the ionisation electrode to the burner mat. The ionisation current at full load must at least amount to 7 µA.
15. If the distance between the electrodes is correct, you can perform a new automatic or manual calibration if the gas pressure matches the data on the nameplate (must only be performed by engineers who have followed training at Multicalor).
16. Check the settings of the appliance with the values listed on the maintenance card that has been stuck on the inside of the front panel.
17. Replace the air filter.
18. Fill in the maintenance card of the appliance.



#### Warning!

- Replace the ionisation electrode and the ignition electrode every 5 years.
- Replace the air filter at least once a year. Using the appliance long term without an air filter can damage the appliance.

# 8 Troubleshooting

## 8.1 Appliance does not start after 5 attempts

Measure the ionisation current by positioning a current meter ( $\mu\text{A}$ ) in series at the ionisation electrode and the burner management control system.

### 8.1.1 An ionisation current is not being formed

If you determine that an ionisation current is not being formed during the ignition phase, this points to a lack of a flame.

Check the following:

1. Check whether the gas valve is open.
2. Check the gas pressure in the supply pipe. This must be in accordance with the technical data.
3. Open the appliance and allow the loose ignition electrode to spark. If a spark is not formed, you must replace the high-voltage cable, the ignition electrode or the control unit.
4. Check whether the protection shut-off valve switches by measuring the voltage.
5. Check whether gas is flowing in the protection shut-off valve by measuring the drop in pressure over the valve during switching.
6. Remove the burner and check the distance between the ignition electrode and the earth electrode. That must amount to approximately 3.5 or 4.0 mm.
7. The bottom side of the ignition electrode must be at a height of 7.2 mm above the metal burner mat.
8. The bottom side of the ionisation electrode must be at a height of 7.2 mm above the metal burner mat. If the ionisation electrode has been significantly deformed, it must be replaced.

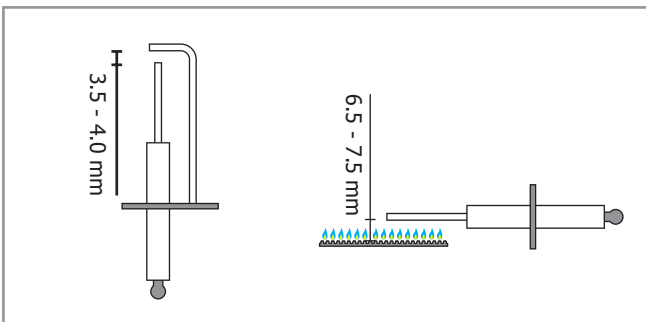

### 8.1.2 An ionisation current is being formed

If you determine that there has been an ionisation current, follow the following tips to find the cause of the problem.

1. First check whether flue gas is not being suctioned. This often happens if the seal in the sliding joint is missing or if the sliding joint has not been installed correctly.
2. Check the gas pressure in the supply pipe. This must be in accordance with the requirements in the technical data table.
3. Check the wiring and specifically the earthing wire and the high-voltage cable that connects the control unit and the ignition electrode and the cable of the ionisation electrode to the burner management control system.
4. Check the starting speed of the fan. Check the burner and the mounting plate for leaks.
5. Replace the burner management control system.



#### Information

Even with an opened front cover suctioned flue gas can lead to the ignition failing. The ionisation current will then fluctuate and this cannot be measured with a standard multimeter.

### 8.1.3 Appliance seems to make a backfiring noise when it is started

The Udara is equipped with a gas-adaptive control. The quantity of gas that is injected is variable and is adjusted by the controller. If the controller does not detect a flame, the controller will inject more gas during the next attempt. If a last ignition attempt is made after the fourth try and suddenly a flame is formed, this may be coupled to a sound like something backfiring. The cause for this, in all cases, is "late spark", in other words, there is a flame flashover at the wrong place and this means that the burner does not or only ignites poorly. The reason can be one of the following causes:

- faulty ignition cable/cracked ignition electrode;
- metal fibres;
- obstructed flashover pipes in the burner;
- faulty heat shield.

Metal fibres are small pieces of fibres that are released from the metal fibre burner and that can be found very close to the ignition electrode. This means that the spark flashes over to the burner mat instead of to the earth electrode of the ignition electrode. You can remove them quickly by simply softly rubbing over the burner with your finger for a second.

### 8.1.4 Ignition flowchart

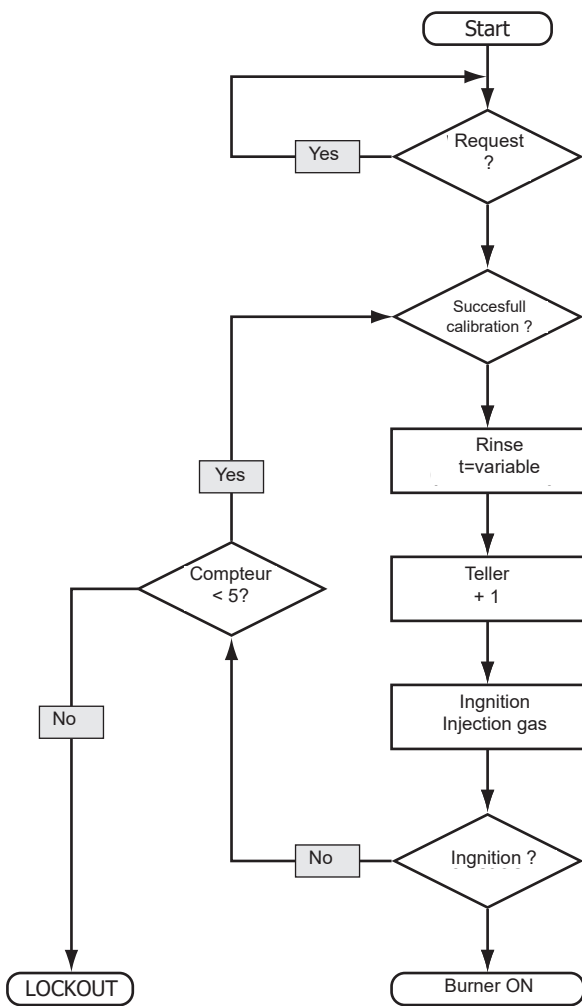

### 8.2 Internal error

Most “internal” errors are caused by a short-circuit in the cable loom or because of a faulty burner management control system.

Check the wiring in accordance with the flowchart and, if required, replace the burner management control system.

### 8.3 Overheating and NTC errors

1. Check the filter for dirt.
2. Check whether sufficient air vents are open.
3. Check whether the ducts are sufficiently large.
4. Check the operation of the system fan and the set air flow rates. If required, increase the set air flow rates or lower the power of the appliance by adjusting parameter TSP 10 in the burner management control system.
5. Ensure that the appliance can blow without obstruction (especially with regard to downflow appliances).
6. Check the operation of the temperature probes. The resistance of the probes will be approximately 10 kOhm at room temperature.

7. Check whether the double NTC (discharge air temperature) has not been exchanged with the single NTC (intake temperature).
8. Check the settings of the temperature protection by comparing the set parameters with the table in the manual.
9. Check the cabling of the NTCs to the burner management control system.

### 8.4 Display does not work

1. Check the power supply.
2. Check the connection of the control unit with the display.
3. Check the fuses on the interface printed circuit board system fan display.
4. Check the flat cable between the interface printed circuit board and the display.



#### Warning!

Pay attention to the correct connection of the flat cable. If you press this incorrectly into the connector, the display can be irreparably damaged.

### 8.5 Flue gas fan operates continuously or not at all

Check the control cable (X23), if the PWM signal to the fan has been interrupted, the flue gas fan runs at high speed. If the control cable is OK, the burner management control system or the flue gas fan will probably be faulty.

If the flue gas fan is not working despite the heat demand, check the cabling and check whether the appliance is not locked. Measure the voltage that must at least be  $230\text{ V} \pm 10\%$ . Replace the flue gas fan or burner management control system if required.

### 8.6 System fan operates continuously or not at all

If the fan is operational continuously, check whether the fan position is set to OFF. If this is not the case, it is normal that the fan is operational.

If the fan is not operational despite the fact that a percentage speed is being displayed on the display, first check the power supply voltage of the fan. If this is OK, check whether the fan can turn freely.

### 8.7 No communication with thermostat

Check the cabling. This must, by preference, be a shielded and twisted cable with a maximum length of 20 m for the RC21.

### 8.8 Fuse or earth leakage circuit breaker intervenes

Measure the appliance to see if there has been a short-circuit. Make sure that a delay fuse has been used. The switchingoff curve must, by preference, be of the type D in view of the starting currents of the motor controls. If the earth leakage circuit breaker is of the 30 mA type, there may not be any other loads on the same earth leakage circuit breaker.

### 8.9 Loss of flame shortly after ignition

Check the FGO and CAS. It is likely that flue gas recirculation takes place and the burner management control system switches off the appliance preventively because the flame is becoming unstable.

Also check the pressure in the gas pipe and also with other consumers switched on.

### 8.10 Service request

If it seems that the fault or failure cannot be resolved, contact the manufacturer for assistance.

Keep the following data at hand:

- the appliance's serial number;
- the gas pressure for the gas valve and type;
- measured power supply voltage;
- last appliance firing report.

### 8.11 Normal settings

Udara HR (DF)		10	15	20	30	40	50
Starting speed flue gas fan	min <sup>-1</sup>	4200					
Maximum flue gas fan speed	min <sup>-1</sup>	5900				6900	
Minimum flue gas fan speed	min <sup>-1</sup>	1500					
Burner off at intake temperature > then	TSP 1 °C	40					
Maximum discharge air temperature (overheat control)	TSP 2 °C	80					
Reserved	TSP 3 °C	--					
Maximum intake temperature (overheat control)	TSP 4 °C	50					
Minimum discharge air temperature	TSP 5 °C	30					
Maximum discharge air temperature	TSP 6 °C	60					
Hysteresis	TSP 7 sec	30					
Post ventilation	TSP 8	30					
Gas type (0 = natural gas, 1 = propane)	TSP 9 #	0 (I2N) / 1 (I3P)					
Maximum power	TSP 10 %	100					
Minimum power	TSP 11 %	0					
Stabilisation time	TSP12 sec	60					
Reserved	TSP13-22 #	--					
Setting code	TSP23 #	0					
Reserved	TSP24-28 #	--					
Starting speed (x 100)	TSP29 min <sup>-1</sup>	42					
Maximum speed (5000 + 20 x TSP)	TSP30 min <sup>-1</sup>	45				95	
Minimum speed (750 + 10 x TSP)	TSP31 min <sup>-1</sup>	75					
Reserved	TSP32-33 #	--					



#### Warning!

Improper changes of the parameters may lead to the appliance no longer working as it should or, in extreme cases, that it even suffers damage.

# 9 Diagram

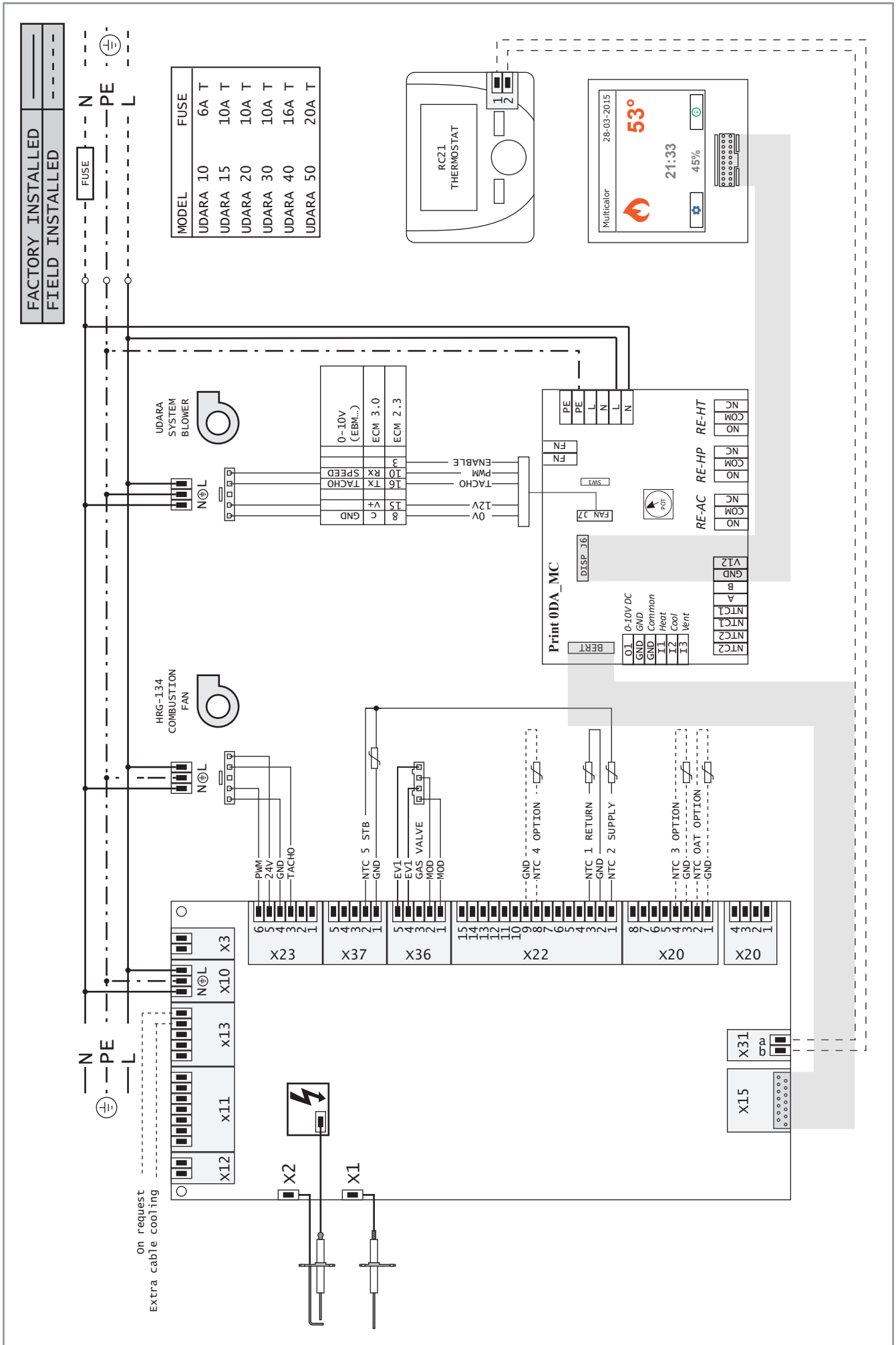

# 10 Parts

## 10.1 Parts list

Udara HR (DF)	10	15	20	30	40	50
System fan	DDMP 146/190 D3G 160	DDEC 9/7		DDEC 10/8	DDEC 10/10	DDEC 12/12
Flue gas fan	HRG 134					
Interface color touchscreen TFT	RA-0D1-UDARA					
Interface Fan	RA-0DA					
Flatcable	RA-FC-UDARA					
Burner management control system	BP-HAGC03					
NTC (double / 3 wires)	NTC-2-UDARA					
NTC (single/ 2 wires)	NTC-1-UDARA					
Ignition electrode	EC-OE-UDARA					
Ionisation electrode	EC-IP-UDARA					
Gas valve	BP-SGV					
Venturi	BP-VENT-4	BP-VENT-4	BP-VENT-5	BP-VENT-8	BP-VENT-6	BP-VENT-6
Mixing box	BP-MCMK-45	BP-MCMK-45	BP-MCMK-30	BP-MCMK-30	BP-MCMK-10	BP-MCMK-00
Burner	BR-UD-10	BR-UD-15	BR-UD-20	BR-UD-30	BR-UD-40	BR-UD-50
Heat shield	PCW-10	PCW-15	PCW-20	PCW-30	PCW-40	PCW-50
Condensate drain (Upflow)	HF-UD-CAL-UPFLOW					
Condensate drain (Downflow)	HF-UD-CAL-DOWNFLOW					
Air filter	LFDF-13-28			LFDF-17-28	LFDF21-28	LFDF-25-28

## 10.2 Ordering procedure

If you need to replace a part, we recommend specifying the related item code when ordering the relevant part as well as specifying the type of air heater, the serial number of the appliance and the name of the part. The appliance type and serial number are specified on the nameplate added to the appliance.

## 10.3 Service request

After purchase, you can request a service if required by contacting the manufacturer. This can through email ([info@multicalor.be](mailto:info@multicalor.be)) or by telephone (+32 15 29 03 03).

Always keep the serial number and appliance type at hand when you contact us.

# 11 Guarantee

## 11.1 In general

Multicalor Industries NV guarantees Udara appliances against all manufacturing errors or material defects based on the terms and conditions described in "Scope and duration of the guarantee". Multicalor Industries NV also guarantees that the appliance will achieve the specified power under normal conditions.

## 11.2 Scope and duration of the guarantee

The guarantee starts when the appliance is sold to the installer and entitles you to the following through the intervention of the dealer or the service department of Multicalor Industries NV:

- two (2) years free exchange of faulty parts except parts that are subject to wear such as filters and ionisation and ignition electrodes;
- two (2) years free labour costs required for the replacement of faulty parts;
- two (2) years free moving costs on condition that the appliance to be repaired is located in Belgium;
- five (5) years free exchange of the heat exchanger including the moving and labour costs on condition that the appliance to be repaired is located in Belgium. This guarantee does not apply if flue gas recirculation is established and/or if the appliance draws hot air into the combustion chamber (operating temperature in heating mode may not exceed 35°C).

If a part is replaced, the original guarantee period will continue to be in force. In other words, the guarantee will not be extended after a faulty part has been replaced.

## 11.3 Damage that is not covered by the guarantee

All damage due to:

- the use of the appliance for non-standard household or slightly commercial purposes;
- not complying with the user instructions listed in the user manual;
- insufficient or incorrect maintenance;
- the heat exchanger becoming dirty because of the firing, ventilation or cooling when there is a significantly contaminated dust filter or this dust filter is not present;
- irreparable internal contamination of the heat exchanger when used in extremely dusty rooms without an intake filter in the CAS; irreparable internal contamination of the heat exchanger when used in extremely dusty rooms without an intake filter in the CAS;
- changes or adjustments to the appliance without the written approval of Multicalor Industries NV;
- repairs performed with non-original or incorrect material
- the heat exchanger when used in an atmosphere contaminated with chlorine or other chemical elements;
- a cause that is strange with regard to the appliance including (but not limited to):

1. damage that occurred during transport such as dents, scratches, etc.;
2. damage caused by emergencies such as fire, lightning or floods;
3. damage that can be blamed on frost;
4. damage caused by the normal electrical voltage deviating or a water or gas pressure that deviates a lot from the nominal values adjusted for the supply of the appliance;
5. damage caused by the installation not being in accordance with the applicable local standards.

## 11.4 The following are not covered by the guarantee

- parts that are subject to normal wear such as air filters, fuel filters, ignition electrodes, ionisation electrodes, heat shields and other parts that need to be replaced regularly;
- appliances of which the serial number was removed or changed;
- movement and labour costs if the guarantee period has elapsed with regard to this;
- consequential damage caused by the faulty appliance;
- any production loss that can be blamed on the faulty appliance;
- any loss of enjoyment caused by the fault to the appliance;
- unsuitability to fulfil the objective for which the buyer bought the appliance.

## 11.5 Repairs

The customer can contact the dealer that sold the appliance or the after-sales service department of Multicalor Industries NV during the guarantee period.

## 11.6 Service sets

If you need to replace a part, we recommend specifying the related item code when ordering the relevant part as well as specifying the type of air heater, the serial number of the appliance and the name of the part. The appliance type and serial number are specified on the nameplate added to the appliance.



## 12.2 Mode

### 12.2.1 Activating the heating and setting the temperature manually

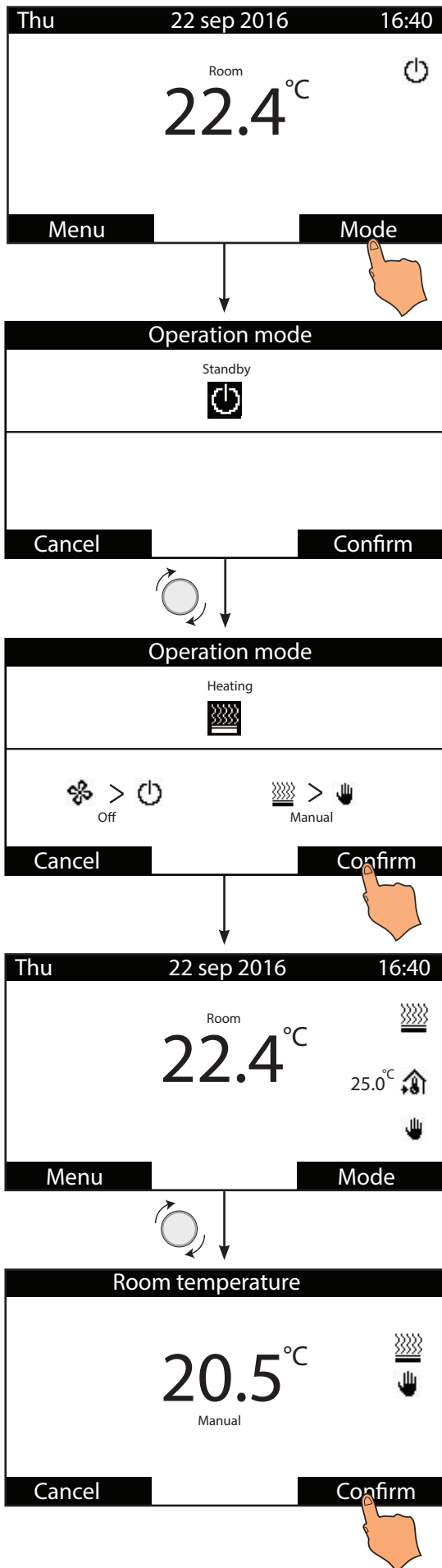

### 12.2.2 Setting the timer program

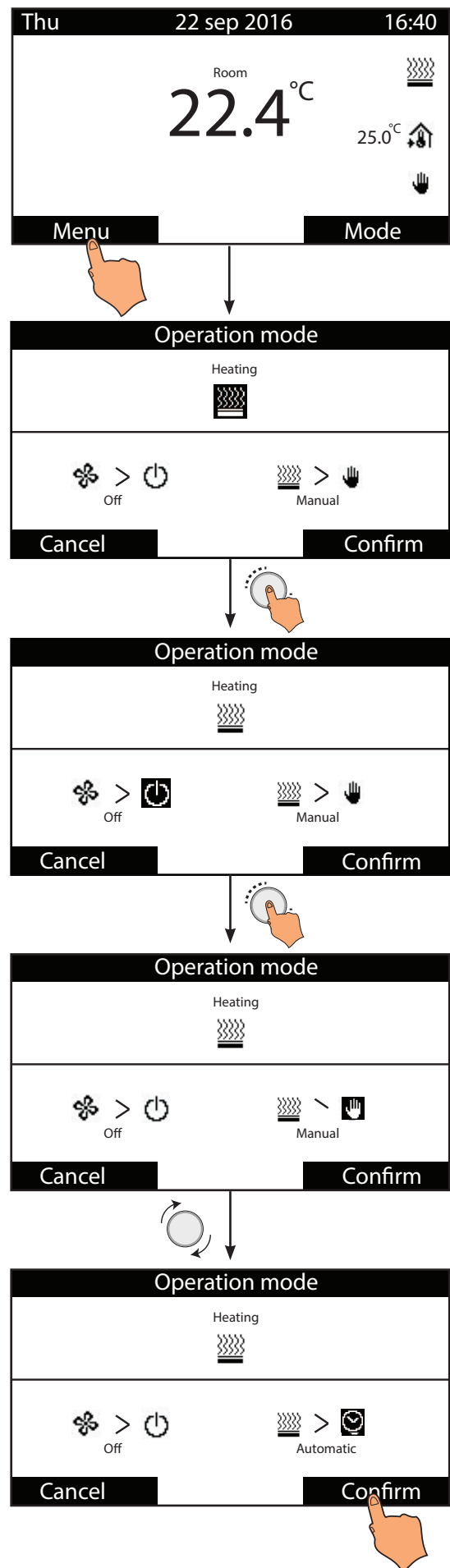

### 12.3 Summer ventilation

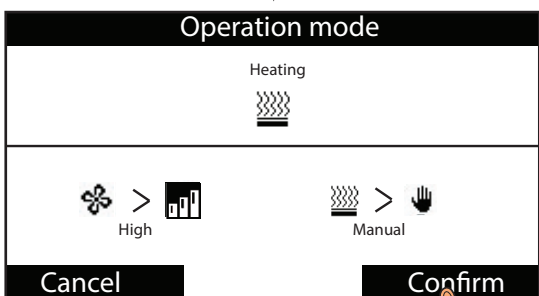
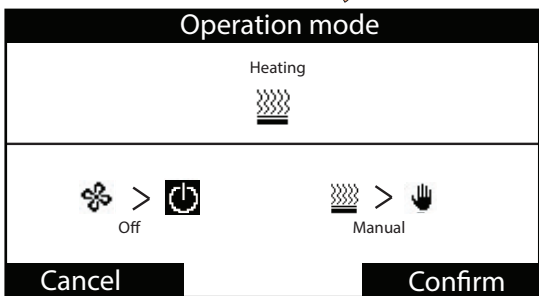
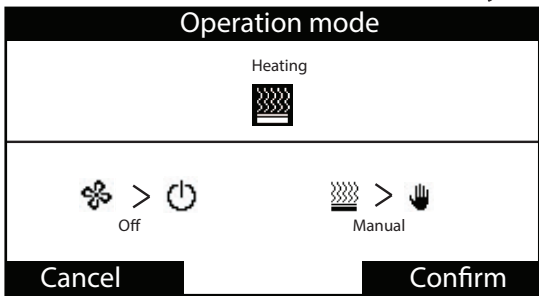
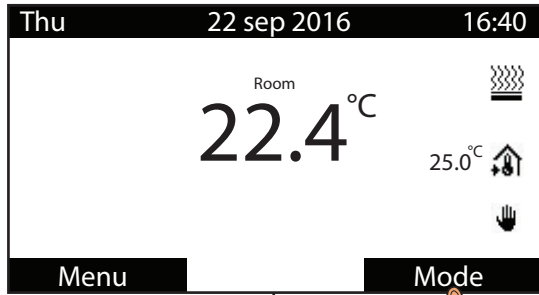

### 12.4 Program

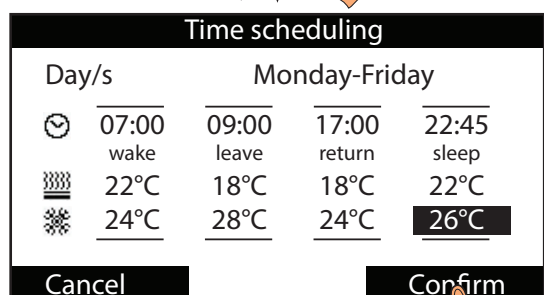
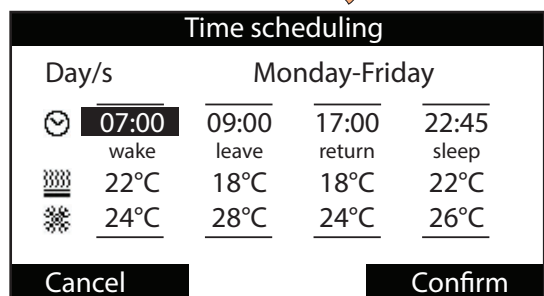
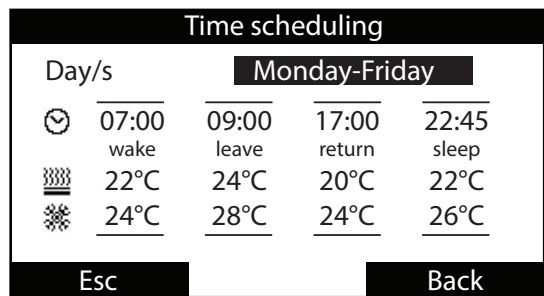
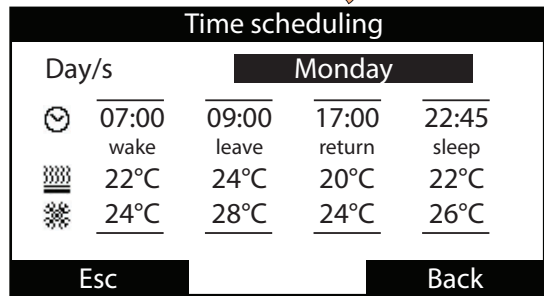
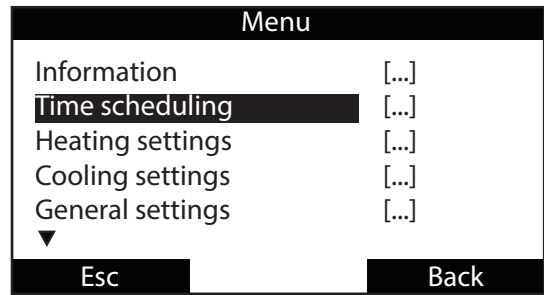

## 12.5 Switching off periods (max. of 2 periods)

**Time scheduling**

Day/s	Saturday-Sunday			
07:00	<b>09:00</b>	17:00	22:45	
wake	leave	return	sleep	
22°C	18°C	18°C	22°C	
24°C	28°C	24°C	26°C	

Cancel Confirm



**Time scheduling**

Day/s	Saturday-Sunday			
07:00	<b>17:00</b>	17:00	22:45	
wake	leave	return	sleep	
22°C	--°C	18°C	22°C	
24°C	--°C	24°C	26°C	

Cancel Confirm



**Time scheduling**

Day/s	Saturday-Sunday			
07:00	<b>22:45</b>	22:45	22:45	
wake	leave	return	sleep	
22°C	--°C	--°C	22°C	
24°C	--°C	--°C	26°C	

Cancel Confirm



**Time scheduling**

Day/s	Saturday-Sunday			
07:00	22:45	22:45	22:45	
wake	leave	return	sleep	
22°C	--°C	--°C	22°C	
24°C	--°C	--°C	<b>26°C</b>	

Cancel Confirm

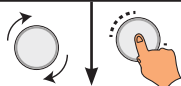

**Time scheduling**

Day/s	Monday-Friday			
07:00	09:00	17:00	22:45	
wake	leave	return	sleep	
22°C	18°C	18°C	22°C	
24°C	28°C	24°C	<b>26°C</b>	

Cancel Confirm



# 13 EC Declaration of conformity

**Multicalor Industries NV**  
**Blarenberglaan 21**  
**2800 Malines (Belgique)**

declares that the gas-fired air heaters

- Multicalor Udara 10 (DF)
- Multicalor Udara 15 (DF)
- Multicalor Udara 20 (DF)
- Multicalor Udara 30 (DF)
- Multicalor Udara 40 (DF)
- Multicalor Udara 50 (DF)

are in accordance with the following directives:

- 2009/142/EC : Gas Appliance Directive
- 2006/42/EC : Machinery Directive
- 2004/108/EC : EMC Directive
- 2006/95/EC : Low Voltage Directive
- 2011/65/EU : Hazardous Substances Directive

and has a CE label with number 1312DO06801 issued by Certigaz SAS, rue du Général Leclerc 1, CS 6054, F92047 Paris la Défense Cedex

Specifically applied harmonised standards:

- EN 1020: Non-household gas-fired air heaters with forced convection for space heating with a net heat load of up to 300 kW and a fan for the transport of the combustion air and/or gases
- EN 1196: Domestic and non-domestic gas-fired air heaters. Supplementary requirements for condensing air heaters
- EN 1319: Domestic gas-fired forced convection air heaters for space heating, with fan-assisted burners not exceeding a net heat input of 70 kW.

Multicalor Industries, moreover, declares that Udara air heaters are produced from high-quality materials and that the appliances are under the permanent quality control of Technigas.

Malines, 2016-05-08



Steven Tolleneer

Directeur Multicalor Industries NV

# 14 Declaration of conformity EU 2016/426

**Multicalor Industries NV**  
**Blarenberglaan 21**  
**2800 Malines (Belgique)**

Declares that the gas-fired air heaters

- Multicalor Udara 10 (DF)
- Multicalor Udara 15 (DF)
- Multicalor Udara 20 (DF)
- Multicalor Udara 30 (DF)
- Multicalor Udara 40 (DF)
- Multicalor Udara 50 (DF)

meet the requirements set in Section 4 of the Royal Decree of 8 January 2004 with regard to emissions of nitrogen oxides and carbon monoxides.

The emissions amount to the following for all types:

Polluant	CO [mg/kWh]	NOx [mg/kWh]
Mesure	< 15	< 30

The EC type investigation as determine in Annex II of the Royal Decree as well as safeguarding the conformity type as determined in Annex III are performed by:

Certigaz SAS, rue du Général Leclerc 1, CS 6054, F92047 Paris la Défense Cedex

Used harmonised standard:

- EN 1020: Non-household gas-fired air heaters with forced convection for space heating with a net heat load of up to 300 kW and a fan for the transport of the combustion air and/or gases
- EN 1196: Domestic and non-domestic gas-fired air heaters. Supplementary requirements for condensing air heaters
- EN 1319: Domestic gas-fired forced convection air heaters for space heating, with fan-assisted burners not exceeding a net heat input of 70 kW.

Malines, 2016-05-08



Steven Tolleneer

Directeur Multicalor Industries NV

# Productsheet warm air heaters as per EU 2016/2281

Type B1 warm air heater	No	Contact details: Multicalor Industries NV-SA Blarenberglaan 21 B7 2800 Mechelen (Belgium) info@multicalor.be
Type C2 warm air heater	No	
Type C4 warm air heater	No	
Type of fuel	GAS	

Item	Symbol	Unit	U-10 (DF)	U-15 (DF)	U-20 (DF)	U-30 (DF)	U-40 (DF)	U-50 (DF)
Capacity								
Rated heating capacity	$P_{rated,h}$	kW	10.6	15.7	21.0	31.4	42.1	52.5
Minimum capacity	$P_{min,h}$	kW	2.0	2.8	3.7	5.6	7.4	9.4
Useful efficiency								
Useful efficiency at rated capacity	$\eta_{nom}$	%	97.13					
Useful efficiency at minimum capacity	$\eta_{pl}$	%	98.37					
Electric power consumption								
At rated heating capacity	$el_{max}$	kW	0.167	0.199	0.258	0.307	0.554	0.611
At minimal capacity	$el_{min}$	kW	0.045	0.059	0.066	0.107	0.172	0.197
In standby mode	$el_{sb}$	kW	0.003	0.003	0.003	0.003	0.003	0.003
Other items								
Envelope loss factor	$F_{env}$	%	0					
Ignition burner power consumption	$P_{ign}$	kW						
Emissions of nitrogen oxides	$N_{ox}$	mg/kWh	< 30 (Class 5)					
Emission efficiency	$\eta_{s,flow}$	%	93.45	93.85	93.85	93.57	93.55	93.46
Seasonal space heating energy efficiency	$\eta_{s,h}$	%	90.17	90.81	90.97	90.76	90.47	90.51

For more information you can contact your installer

Read this document before starting the installation or using the appliance. After commissioning, give instructions to the user and keep this document in the immediate vicinity of the appliance. This appliance may not be operated by children, people with a diminished mental capacity, physical impairments or lack of knowledge unless under supervision or after receiving training on how to use the appliance safely and as long as they are aware of the possible risks. Children may not play with the appliance under any circumstances. Cleaning and maintenance performed by the user may never be carried out by children without supervision

**Multicalor Industries NV**

Blarenberglaan 21 • B-2800 Malines  
Tel.: +32 15 29 03 03 • Fax: +32 15 29 03 20  
info@multicalor.be • www.multicalor.be

IHL\_UDARA\_2023\_BEGB

