

# HE PLUS 1400/2000

## **ELECTRONIC WHOLE-HOUSE AIR CLEANERS**

Trion's high performance HE Plus 1400/2000 Electronic Air Cleaners are examples of Trion's dedication to quality and continuous improvement. Trion's residential electronic air cleaners are recognized by dealers nationwide for the strongest cabinets, most reliable power supplies, and the sturdiest cells in the industry. The HE series requires minimal maintenance and is available in 1400 cfm (2379 m<sup>3</sup>/hr) and 2000 cfm (3398 m<sup>3</sup>/hr) sizes.



### **FEATURES/BENEFITS**

- Dealer-focused design includes an easy-access power supply, mounted so it can be easily removed to simplify and shorten on-site servicing. Other parts “snap-in” for simplified service as well.
- Interchangeable power supply compatible with Trion's SE electronic air cleaner.
- Built-in internal fuse protects the 24V transformer in the event of a power supply failure.
- Standard built-in air flow sensor.
- Fail-safe connection of built-in air flow sensor eliminates the possibility of incorrect wiring by the service technician.
- Permanent, washable, all-aluminum and stainless steel collection cells for longer service life.
- Increases the efficiency of HVAC systems by keeping cooling coils clean.
- Aluminum mesh pre-filter traps large particles such as dirt, lint, and pet hair.
- Optional charcoal after-filter reduces common household odors.
- Easy-to-clean cells and replacement filters.
- Easily converted to 240V.
- Available in 1400 cfm (2379 m<sup>3</sup>/hr) or 2000 cfm (3398 m<sup>3</sup>/hr).
- 180-day dealer labor allowance.
- Three-year limited warranty.
- U.L./C.U.L. listed.

# HE PLUS 1400/2000 AIR CLEANERS SPECIFICATIONS

MODEL	HE PLUS 1400—16x25	HE PLUS 1400—20x20	HE PLUS 2000—20x25
PART NO.	455601-001	455603-001	455600-001
MAX. CAPACITY	1400 cfm (2379 m <sup>3</sup> /hr)	1400 cfm (2379 m <sup>3</sup> /hr)	2000 cfm (3398 m <sup>3</sup> /hr)
CELL WEIGHT	(2) 10 lbs. (4.54 kg) each	(2) 9 lbs. (4.09 kg) each	(2) 12 lbs. (5.44 kg) each
UNIT WEIGHT	32 lbs. (14.5 kg)	36 lbs. (16.3 kg)	36 lbs. (16.3 kg)
ELECTRICAL INPUT	120V, 50/60Hz, 1 ph	120V, 50/60Hz, 1 ph	120V, 50/60Hz, 1 ph
ELECTRICAL OUTPUT	2.5 mADC	2.5 mADC	3.2 mADC
DIMENSIONS			
A	20 <sup>1</sup> / <sub>4</sub> " (514 mm)	24 <sup>1</sup> / <sub>4</sub> " (616 mm)	24 <sup>1</sup> / <sub>4</sub> " (616 mm)
B	13 <sup>7</sup> / <sub>8</sub> " (352 mm)	17 <sup>7</sup> / <sub>8</sub> " (454 mm)	17 <sup>7</sup> / <sub>8</sub> " (454 mm)
C	16 <sup>15</sup> / <sub>16</sub> " (430 mm)	20 <sup>15</sup> / <sub>16</sub> " (532 mm)	20 <sup>15</sup> / <sub>16</sub> " (532 mm)
D	22 <sup>1</sup> / <sub>2</sub> " (572 mm)	19" (483 mm)	22 <sup>1</sup> / <sub>2</sub> " (572 mm)
E	24 <sup>7</sup> / <sub>8</sub> " (632 mm)	21 <sup>3</sup> / <sub>8</sub> " (543 mm)	24 <sup>7</sup> / <sub>8</sub> " (632 mm)
F	7 <sup>1</sup> / <sub>8</sub> " (181 mm)	7 <sup>1</sup> / <sub>8</sub> " (181 mm)	7 <sup>1</sup> / <sub>8</sub> " (181 mm)
G	21 <sup>7</sup> / <sub>16</sub> " (541 mm)	18 <sup>5</sup> / <sub>8</sub> " (473 mm)	21 <sup>7</sup> / <sub>16</sub> " (541 mm)

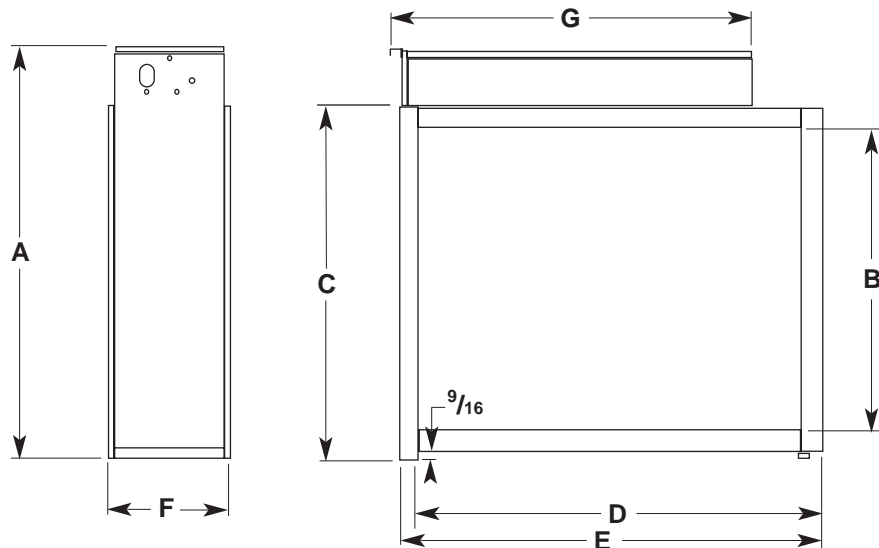

Corporate Office: 101 McNeill Road • Sanford, NC 27330

For Inquiries: Phone: 800-225-6753 • Fax: 866-314-6449 • [www.trioninc.com](http://www.trioninc.com) • email: [residentialsales@fedders.com](mailto:residentialsales@fedders.com)  
Trion, Inc., having a policy of continuous product improvement, reserves the right to make changes in design and specification without notice.

Form No. 02-0338P • ©2003, Trion, Inc. • 6/03