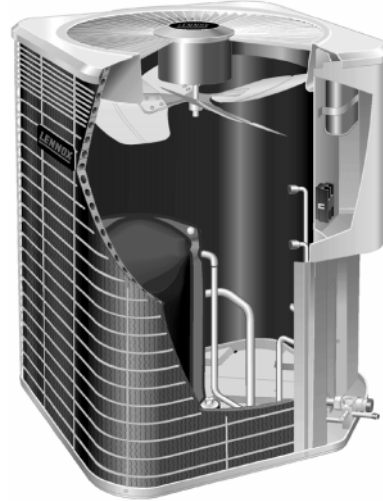
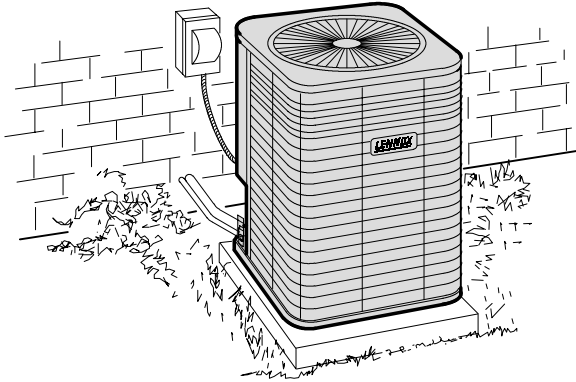

Typical Application**FEATURES****Applications**

- Energy Efficiency Ratios (EER's) of up to 10.15.
- 5.3 through 17.5+ kW (1.5 through 5+ Ton) sizes.
- Vertical air discharge allows concealment behind shrubs at grade level or out of sight on a roof.
- Matching blower powered or add-on furnace evaporator units provide a wide range of cooling capacities and applications. See Ratings table.
- For evaporator unit data, see Coils- Blower Coil Units, this section.
- Units shipped completely factory assembled, piped and wired. Each unit is test operated at the factory insuring proper operation.
- Installer must set condensing unit, connect refrigerant lines and make electrical connections to complete job.

Refrigerant

- For use with non-chlorine, ozone friendly, R-407C.
- Unit is shipped with nitrogen holding charge.
- Unit **Must be Field Charged** with refrigerant. See unit name plate for amount required.

Completely Tested

- Tested in the Lennox Research Laboratory environmental test rooms which meet American Society of Heating, Refrigeration and Air-Conditioning Engineers (ASHRAE) Standard 37 requirements.
- Rating test conditions are those included in Air-Conditioning and Refrigeration Institute (ARI) Standard 210/240-94 while operating at rated voltages and air volumes.
- Sound rated in Lennox reverberant sound test room in accordance with test conditions included in Air Conditioning and Refrigeration Institute ARI Standard 270-95.
- Condensing units and components within bonded for grounding to meet safety standards for servicing required by Underwriters Laboratories (UL) and the International Electrotechnical Commission (IEC).
- Developed in accordance with International Standards Organization (ISO) 9000 quality standards.

Unit Cabinet

- Heavy gauge steel cabinet with five station metal wash process.
- Powder coat paint finish provides rust and corrosion protection.
- Painted base section.
- Control box is conveniently located with all controls factory wired.
- Two pole contactor for improved reliability.
- Corner patch plate allows access to compressor.
- Drainage holes are provided in base section for moisture removal.

Copeland® Compliant Scroll Compressor

- Compressor features high efficiency with uniform suction flow, constant discharge flow and high volumetric efficiency and quiet operation.
- Compressor consists of two involute spiral scrolls matched together to generate a series of crescent shaped gas pockets between them.
- During compression, one scroll remains stationary while the other scroll orbits around it.
- Gas is drawn into the outer pocket, the pocket is sealed as the scroll rotates.
- As the spiral movement continues, gas pockets are pushed to the center of the scrolls. Volume between the pockets is simultaneously reduced.
- When pocket reaches the center, gas is now at high pressure and is forced out of a port located in the center of the fixed scrolls.
- During compression, several pockets are compressed simultaneously resulting in a smooth continuous compression cycle.
- Continuous flank contact, maintained by centrifugal force, minimizes gas leakage and maximizes efficiency.
- Scroll compressor is tolerant to the effects of slugging and contaminants. If this occurs, scrolls separate, allowing liquid or contaminants to be worked toward the center and discharged.
- Low gas pulses during compression reduces operational sound levels.
- Compressor motor is internally protected from excessive current and temperature.
- Compressor is installed in the unit on resilient rubber mounts for vibration free operation.



FEATURES

Copper Tube/Enhanced Fin Coil

- Lennox designed and fabricated coil.
- Ripple-edged aluminum fins.
- Copper tube construction.
- Lanced fins provide maximum exposure of fin surface to air stream resulting in excellent heat transfer.
- Fin collars grip tubing for maximum contact area.
- Flared shoulder tubing connections/silver soldering construction.
- Coil is factory tested under high pressure to insure leakproof construction.
- Entire coil is accessible for cleaning.
- Polyvinyl chloride (PVC) coated steel wire coil guard furnished as standard.

Condenser Fan

- Direct drive fan moves large air volumes uniformly through entire condenser coil for high refrigerant cooling capacity.
- Vertical air discharge minimizes operating sounds and eliminates damage to lawn and shrubs.
- Fan motor has sleeve bearings and is inherently protected.
- Motor totally enclosed for maximum protection from weather, dust and corrosion.
- Rain shield on motor provides additional protection from moisture.
- Louvered steel top fan guard furnished as standard.
- Fan service access accomplished by removal of fan guard.

High Pressure Switch

- Manual reset switch shuts off unit if abnormal operating conditions cause discharge pressure to rise above setting.

Low Pressure Switch

- Automatic reset switch shuts off unit if suction pressure falls below setting. Provides loss of charge and freeze-up protection.

Refrigerant Line Connections, Electrical Inlets, Service Valves

- Sweat connection suction and liquid lines are located on corner of unit cabinet.
- Fully serviceable brass service valves prevent corrosion and provide access to refrigerant system. Suction valve can be fully shut off, while liquid valve may be backseated to manage refrigerant charge while servicing system.
- 45° elbow furnished for ease of suction line connection.
- 9.5 x 7.9 mm (3/8 x 5/16 in.) reducer bushing furnished with HS40-018-024 models for liquid line connection.
- Units are stubbed with 9.5 mm (3/8 in.) connection.
- Field installed thermometer well furnished for installation in the liquid line to check refrigerant charge.
- Refrigerant line connections and field wiring inlets are located in one central area of cabinet for easy access. See dimension drawing.

Expansion Valve Kits

- **Expansion valve shipped with condensing unit MUST be field installed on evaporator unit. Factory installed expansion valves on evaporator units MUST be replaced with valve shipped with condensing unit.**
- Chatleff style fitting.
- Furnished as standard for field installation.

OPTIONAL ACCESSORIES (MUST BE ORDERED EXTRA)

Thermostat

- Thermostat not furnished with unit. See Lennox Price Book.

Low Ambient Kit

- Condensing units operate satisfactorily down to 7°C (45°F) outdoor air temperature without any additional controls.
- Low Ambient Control Kit LB-57113BC (**24H77**) can be field installed, allowing proper unit operation down to -1°C (30°F).

Unit Stand-Off Kit

- Black high density polyethylene feet (**94J45**) are available to raise unit off of mounting surface away from damaging moisture.
- Four feet are furnished per order number.

Refrigerant Line Kits

- Shipped refrigeration clean.
- Lines are cleaned, dried, pressurized and sealed at factory.
- Suction line fully insulated.
- Stubbed at both ends.
- See Refrigerant Line Kit table for selection.
- Kits are not available for HS40-065 models and must be field fabricated.

Crankcase Heater

- Crankcase heater (**90P12**) prevents migration of liquid refrigerant into compressor and ensures proper compressor lubrication.

SPECIFICATIONS						
Model Number		HS40-018	HS40-024	HS40-036	HS40-048	HS40-065
Nominal kW (Tonnage)		5.3 (1.5)	7.0 (2)	10.5 (3)	14.0 (4)	17.5+ (5+)
Liquid line connection - outside diameter - mm (in.) sweat		*9.5 (3/8)		9.5 (3/8)		
Suction line connection - outside diameter - mm (in.) sweat		15.9 (5/8)		19.1 (3/4)	22.2 (7/8)	28.6 (1-1/8)
†Refrigerant charge		Nitrogen holding charge				
Condenser Coil	Net face area — m ² (ft. ²)	Outer coil	1.05 (11.33)		1.40 (15.11)	
		Inner coil	-----		0.50 (5.40)	1.88 (20.20)
	Tube outside diameter - mm (in.)		7.9 (5/16)			
	Number of rows		1		1.38	2
Fins per m (inch)		866 (22)			708 (18)	
Condenser Fan	Diameter — mm (in.)		457 (18)			559 (22)
	Number of blades		3		4	
	Motor output — W (hp)		125 (1/6)		250 (1/3)	
	Air volume — L/s (cfm)		865 (1833)		990 (2100)	1160 (2460)
	Rev/Min		930		925	
	Motor input — W		126		237	288
Electrical Characteristics - 50hz		220/240v - 1 phase		220/240v - 1 phase, 380/420v -3 phase		380/420v -3 phase
Shipping weight — kg (lbs.) 1 package		66 (146)	67 (148)	76 (167)	97 (215)	115 (254)
OPTIONAL ACCESSORIES - MUST BE ORDERED EXTRA						
Low Ambient Kit		24H77				
Unit Stand-Off Kit		94J45				
Crankcase Heater		90P12				

†R-407C refrigerant MUST be field supplied, see name plate for required amount.
 *Furnished with 9.5 mm x 8 mm (3/8 inch x 5/16 inch) reducer adaptor for refrigerant line connections.

ELECTRICAL DATA							
Model Number		HS40-018	HS40-024	HS40-036	HS40-036	HS40-048	HS40-065
Line voltage and phase (50hz)		220/240V - 1 phase			380/420V 3 phase with neutral	†380/420V - 3 phase	
Voltage range (minimum — maximum)		198 — 264V			342 — 462V	342 — 462V	342 — 462V
Compressor	Rated load amps	8.7	10.3	15.4	6.41	9.0	9.0
	Locked rotor amps	47	60.0	97.0	46.0	64.0	74.0
Condenser Coil Fan Motor (1 phase)	Full load amps	1.0			.6	.8	
	Locked rotor amps	1.9			1.0	2.1	

NOTE — Refer to local electrical codes to determine wire, fuse and disconnect size requirements.
 †Neutral required with optional Transformer Kit (16F34).

FIELD WIRING

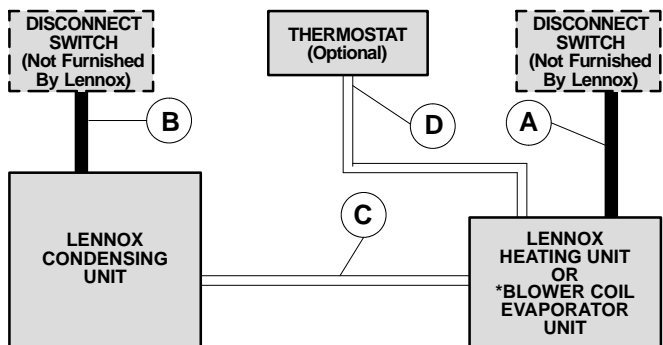

- A — Single Phase or Three Phase with Neutral
 - B — Single Phase, Three Phase with Neutral or Three Phase — See Electrical Data
 - C — Two wire 24V
Three wire 24V with optional Transformer Kit (16F34)
 - D — Four Wire 24V
- NOTE — Field wiring not furnished by Lennox.
 All wiring must conform to local electrical codes.
 *CB/CBH17 applications without electric heat require a separate 70VA (minimum rating) transformer.

RATINGS

Condensing Unit Model Number (*Sound Rating Number-db)	●Cooling Ratings							Up-Flow	Down Flow	Horizontal	**Expansion Valve Kit Required
	Gross Total Cooling Capacity		†Net Total Cooling Capacity		Total Power Input kW	Coefficient of Performance (Output/Input)	Energy Efficiency Ratio (Btuh/Watt)				
	kW	Btuh	kW	Btuh				Blower Coils			
HS40-018 (74)	5.4	18 500	5.7	19 300	1825	3.10	10.15	CB29M-21/26 (Multi-Position)			
HS40-024 (74)	6.4	21 800	6.7	22 800	2347	2.85	9.30	CB29M-21/26 (Multi-Position)			
HS40-036 (76)	9.8	33 400	10.3	35 000	4029	2.55	8.30	CBM29-31/41 (Multi-Position)			
	10.5	35 800	10.9	37 200	4111	2.65	8.70	CB29M-51 (Multi-Position)			
HS40-048 (82)	11.7	40 000	12.2	41 500	4933	2.47	8.10	CBM29-31/41 (Multi-Position)			
	13.5	46 000	14.1	48 000	5402	2.60	8.50	CB29M-51 (Multi-Position)			
HS40-065 (80)	16.0	54 500	16.6	56 500	6225	2.66	8.75	CB29M-51 (Multi-Position)			
	16.3	55 500	17.6	60 000	6995	2.51	7.95	CB29M-65 (Multi-Position)			

*Sound rating number rated at test conditions included in Air-Conditioning and Refrigeration Institute (ARI) Standard 270-95.

●The rating test conditions are those included in Air-Conditioning and Refrigeration Institute (ARI) Standard 210/240-94 while operating at rated voltage and air volumes.
Cooling Ratings — 35°C (95°F) outdoor air temperature, 26.7°C (80°F) dry bulb and 19.4°C (67°F) wet bulb entering evaporator air with 6.0 m (20 feet) of connecting refrigerant lines.

**Expansion valve kit is optional and must be ordered extra, unless shown as factory installed.

†Net Cooling Capacity = Gross Cooling Capacity - Heat added by indoor blower motor (365W per 1000 cfm (0.47 m³/s or 3.413 Btu/W on blower coils)

Expansion valve shipped with condensing unit **MUST** be field installed on evaporator unit.

Factory installed expansion valves on evaporator units **MUST** be replaced with valve shipped with condensing unit.

REFRIGERANT LINE KITS

Condensing Unit Model Number	Line Set Model Number	Length of Lines		Liquid Line Outside Diameter		Suction Line Outside Diameter	
		ft.	m	in.	mm	in.	mm
HS40-018 HS40-024	L15-21-20	20	6	5/16	7.9	5/8	15.9
	L15-21-25	25	8				
	L15-21-35	35	11				
	L15-21-50	50	15				
HS40-036	L15-41-20	20	6	3/8	9.5	3/4	19
	L15-41-30	30	9				
	L15-41-40	40	12				
	L15-41-50	50	15				
HS40-048	L15-65-30	30	9	3/8	9.5	7/8	22.2
	L15-65-40	40	12				
	L15-65-50	50	15				
HS40-065	Field Fabricate			3/8	9.5	1-1/8	28.5

INSTALLATION CLEARANCES - MM (IN.)

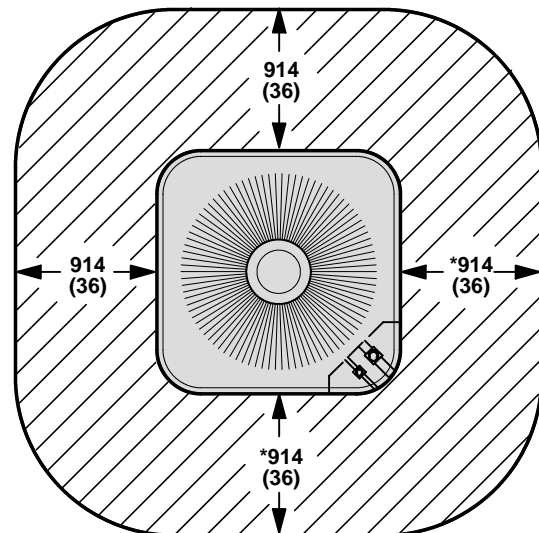

NOTE — 1219 mm (48 inch) clearance required on top of unit.
***NOTE** — One side must be 914 mm (36 inches) for service.
 Two of the remaining three sides may be 305 mm (12 inches).

DIMENSIONS – MM (INCHES)

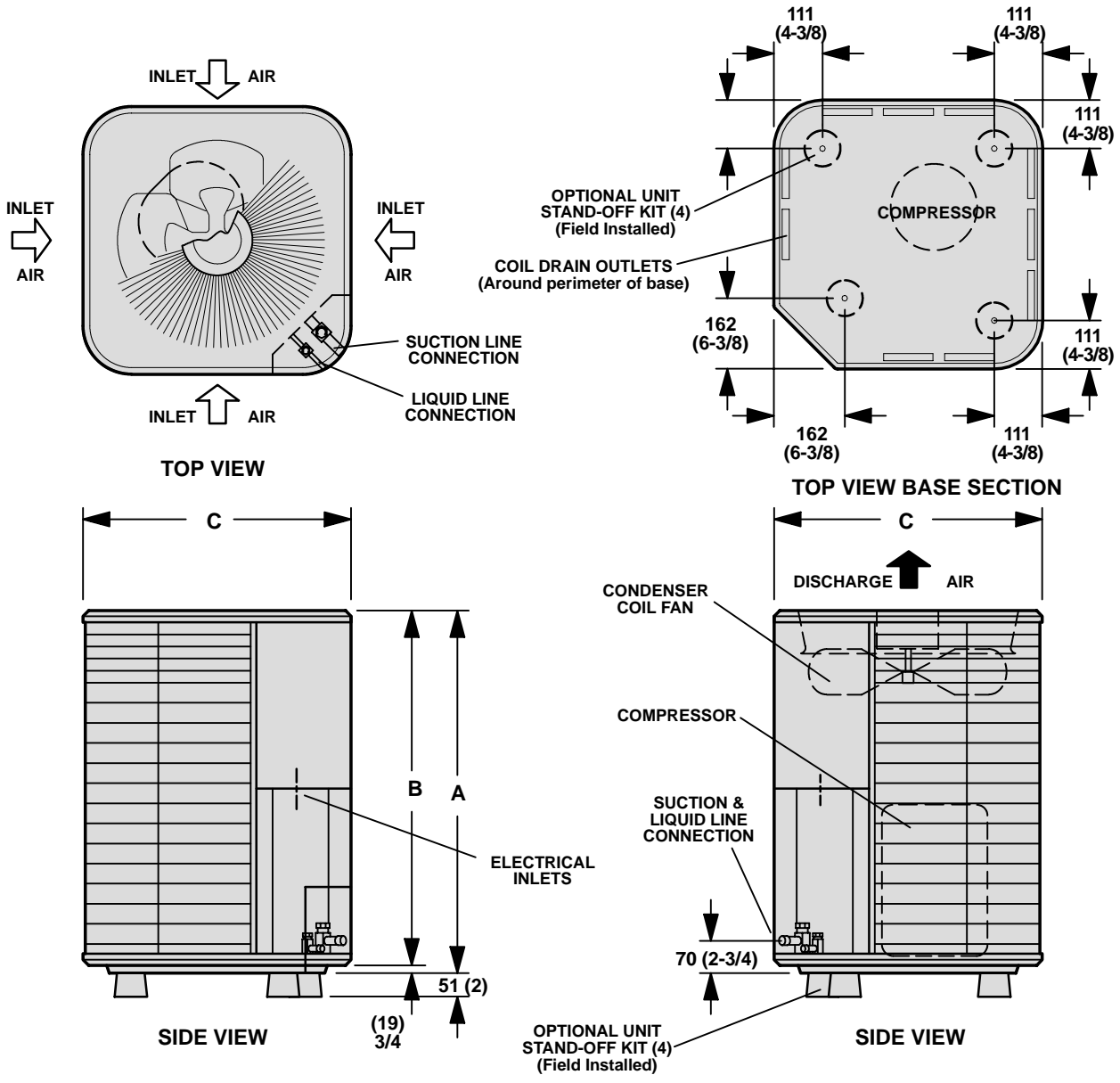

Model Number		A	B	C
HS40-018 HS40-024	mm	635	616	616
	in.	25	24-1/4	24-1/4
HS40-036 HS40-048	mm	838	819	616
	in.	33	32-1/4	24-1/4
HS40-065	mm	946	927	718
	in.	37-1/4	36-1/2	28-1/4

RATINGS – 50HZ

NOTE For Temperatures and Capacities not shown, see bulletin — Cooling Unit Rating Table Correction Factor Data in Miscellaneous Engineering Data Section. All values are gross capacities and do not include evaporator coil blower motor heat deduction.

HS40-018 — CB29M-21/26 COOLING CAPACITY

Entering Wet Bulb Temperature	Total Air Volume		Outdoor Air Temperature Entering Outdoor Coil																													
			29°C (85°F)						35°C (95°F)						41°C (105°F)						46°C (115°F)											
			Total Cooling Capacity		Comp Motor kW Input		Sensible To Total Ratio (S/T)			Total Cooling Capacity		Comp Motor kW Input		Sensible To Total Ratio (S/T)			Total Cooling Capacity		Comp Motor kW Input		Sensible To Total Ratio (S/T)			Total Cooling Capacity		Comp Motor kW Input		Sensible To Total Ratio (S/T)				
							Dry Bulb							Dry Bulb							Dry Bulb							Dry Bulb				
m³/s	cfm	kW	kBtuh	24°C 75°F	27°C 80°F	29°C 85°F	kW	kBtuh	Input	24°C 75°F	27°C 80°F	29°C 85°F	kW	kBtuh	Input	24°C 75°F	27°C 80°F	29°C 85°F	kW	kBtuh	Input	24°C 75°F	27°C 80°F	29°C 85°F	kW	kBtuh	Input	24°C 75°F	27°C 80°F	29°C 85°F		
17°C (63°F)	.30	650	5.6	19.0	1.29	.76	.91	1.00	5.3	18.2	1.46	.77	.93	1.00	5.0	17.2	1.67	.80	.96	1.00	5.0	17.0	1.93	.82	.99	1.00	4.7	16.2	1.92	.82	.99	1.00
	.38	800	5.8	19.8	1.29	.81	.97	1.00	5.5	18.9	1.47	.83	.99	1.00	5.3	18.0	1.68	.86	1.00	1.00	5.0	17.0	1.93	.89	1.00	1.00	5.0	17.0	1.93	.89	1.00	1.00
	.45	950	6.0	20.5	1.30	.87	1.00	1.00	5.7	19.6	1.48	.89	1.00	1.00	5.5	18.6	1.69	.92	1.00	1.00	5.2	17.6	1.93	.95	1.00	1.00	5.2	17.6	1.93	.95	1.00	1.00
19°C (67°F)	.30	650	5.9	20.2	1.30	.58	.73	.88	5.6	19.2	1.47	.59	.75	.90	5.3	18.2	1.68	.60	.77	.93	5.0	17.0	1.93	.62	.80	.96	5.0	17.0	1.93	.62	.80	.96
	.38	800	6.1	20.8	1.30	.62	.79	.95	5.8	19.7	1.48	.63	.81	.97	5.5	18.6	1.69	.64	.84	.99	5.1	17.5	1.94	.66	.87	1.00	5.1	17.5	1.94	.66	.87	1.00
	.45	950	6.2	21.2	1.30	.65	.84	.99	5.9	20.1	1.48	.67	.87	1.00	5.6	19.0	1.69	.68	.90	1.00	5.2	17.8	1.94	.71	.93	1.00	5.2	17.8	1.94	.71	.93	1.00
22°C (71°F)	.30	650	6.3	21.6	1.31	.43	.57	.71	6.0	20.6	1.49	.43	.58	.72	5.7	19.4	1.69	.43	.59	.74	5.3	18.2	1.94	.44	.61	.77	5.3	18.2	1.94	.44	.61	.77
	.38	800	6.5	22.1	1.31	.44	.60	.76	6.2	21.0	1.49	.44	.62	.78	5.8	19.9	1.70	.45	.63	.81	5.5	18.6	1.95	.46	.65	.84	5.5	18.6	1.95	.46	.65	.84
	.45	950	6.6	22.5	1.31	.45	.64	.82	6.3	21.4	1.49	.46	.65	.85	5.9	20.1	1.71	.47	.68	.88	5.5	18.9	1.95	.48	.70	.91	5.5	18.9	1.95	.48	.70	.91

HS40-024 — CB29M-21/26 COOLING CAPACITY

Entering Wet Bulb Temperature	Total Air Volume		Outdoor Air Temperature Entering Outdoor Coil																													
			29°C (85°F)						35°C (95°F)						41°C (105°F)						46°C (115°F)											
			Total Cooling Capacity		Comp Motor kW Input		Sensible To Total Ratio (S/T)			Total Cooling Capacity		Comp Motor kW Input		Sensible To Total Ratio (S/T)			Total Cooling Capacity		Comp Motor kW Input		Sensible To Total Ratio (S/T)			Total Cooling Capacity		Comp Motor kW Input		Sensible To Total Ratio (S/T)				
							Dry Bulb							Dry Bulb							Dry Bulb							Dry Bulb				
m³/s	cfm	kW	kBtuh	24°C 75°F	27°C 80°F	29°C 85°F	kW	kBtuh	Input	24°C 75°F	27°C 80°F	29°C 85°F	kW	kBtuh	Input	24°C 75°F	27°C 80°F	29°C 85°F	kW	kBtuh	Input	24°C 75°F	27°C 80°F	29°C 85°F	kW	kBtuh	Input	24°C 75°F	27°C 80°F	29°C 85°F		
17°C (63°F)	.30	650	6.4	21.9	1.67	.71	.86	.98	6.1	20.8	1.90	.72	.88	1.00	5.8	19.7	2.17	.74	.91	1.00	5.4	18.5	2.49	.77	.94	1.00	5.4	18.5	2.49	.77	.94	1.00
	.38	800	6.6	22.6	1.68	.76	.93	1.00	6.3	21.6	1.91	.78	.95	1.00	6.0	20.5	2.17	.81	.97	1.00	5.7	19.3	2.50	.83	.99	1.00	5.7	19.3	2.50	.83	.99	1.00
	.45	950	6.8	23.3	1.68	.81	.98	1.00	6.5	22.3	1.91	.83	.99	1.00	6.2	21.2	2.18	.86	1.00	1.00	5.9	20.0	2.51	.90	1.00	1.00	5.9	20.0	2.51	.90	1.00	1.00
19°C (67°F)	.30	650	6.8	23.3	1.68	.55	.68	.82	6.5	22.2	1.91	.56	.70	.84	6.1	20.9	2.18	.57	.72	.87	5.7	19.6	2.51	.58	.74	.91	5.7	19.6	2.51	.58	.74	.91
	.38	800	7.0	23.9	1.69	.58	.74	.89	6.7	22.8	1.92	.59	.75	.92	6.3	21.5	2.19	.60	.78	.95	5.9	20.1	2.51	.62	.81	.98	5.9	20.1	2.51	.62	.81	.98
	.45	950	7.2	24.4	1.69	.61	.78	.95	6.8	23.2	1.92	.62	.81	.98	6.4	21.9	2.20	.64	.84	.99	6.0	20.5	2.52	.66	.88	1.00	6.0	20.5	2.52	.66	.88	1.00
22°C (71°F)	.30	650	7.3	24.9	1.70	.41	.54	.66	6.9	23.7	1.93	.41	.54	.67	6.6	22.4	2.20	.42	.55	.70	6.2	21.0	2.53	.42	.57	.72	6.2	21.0	2.53	.42	.57	.72
	.38	800	7.5	25.5	1.70	.42	.57	.71	7.1	24.3	1.93	.43	.58	.73	6.7	22.9	2.21	.43	.59	.75	6.3	21.5	2.54	.44	.61	.78	6.3	21.5	2.54	.44	.61	.78
	.45	950	7.6	26.0	1.71	.43	.60	.76	7.2	24.7	1.94	.44	.61	.79	6.8	23.3	2.22	.45	.63	.81	6.4	21.8	2.54	.45	.65	.85	6.4	21.8	2.54	.45	.65	.85

HS40-036 — CB29M-31/41 COOLING CAPACITY

Entering Wet Bulb Temperature	Total Air Volume		Outdoor Air Temperature Entering Outdoor Coil																													
			29°C (85°F)						35°C (95°F)						41°C (105°F)						46°C (115°F)											
			Total Cooling Capacity		Comp Motor kW Input		Sensible To Total Ratio (S/T)			Total Cooling Capacity		Comp Motor kW Input		Sensible To Total Ratio (S/T)			Total Cooling Capacity		Comp Motor kW Input		Sensible To Total Ratio (S/T)			Total Cooling Capacity		Comp Motor kW Input		Sensible To Total Ratio (S/T)				
							Dry Bulb							Dry Bulb							Dry Bulb							Dry Bulb				
m³/s	cfm	kW	kBtuh	24°C 75°F	27°C 80°F	29°C 85°F	kW	kBtuh	Input	24°C 75°F	27°C 80°F	29°C 85°F	kW	kBtuh	Input	24°C 75°F	27°C 80°F	29°C 85°F	kW	kBtuh	Input	24°C 75°F	27°C 80°F	29°C 85°F	kW	kBtuh	Input	24°C 75°F	27°C 80°F	29°C 85°F		
17°C (63°F)	.47	1000	9.8	33.6	2.96	.70	.85	.97	9.4	32.0	3.38	.72	.87	.99	8.9	30.3	3.88	.74	.90	1.00	8.4	28.5	4.48	.76	.93	1.00	8.4	28.5	4.48	.76	.93	1.00
	.56	1200	10.1	34.6	2.98	.75	.91	1.00	9.7	33.0	3.40	.77	.93	1.00	9.2	31.3	3.91	.79	.96	1.00	8.6	29.5	4.51	.81	.98	1.00	8.6	29.5	4.51	.81	.98	1.00
	.66	1400	10.4	35.5	3.00	.79	.96	1.00	9.9	33.9	3.42	.81	.98	1.00	9.4	32.2	3.92	.84	.99	1.00	8.9	30.4	4.54	.87	1.00	1.00	8.9	30.4	4.54	.87	1.00	1.00
19°C (67°F)	.47	1000	10.5	35.8	3.00	.55	.68	.82	10.0	34.1	3.42	.56	.70	.84	9.4	32.2	3.93	.57	.72	.86	8.9	30.2	4.52	.58	.74	.90	8.9	30.2	4.52	.58	.74	.90
	.56	1200	10.7	36.6	3.02	.58	.72	.88	10.2	34.9	3.44	.59	.74	.90	9.6	32.9	3.95	.60	.76	.93	9.1	30.9	4.56	.61	.79	.96	9.1	30.9	4.56	.61	.79	.96
	.66	1400	10.9	37.3	3.03	.60	.77	.93	10.4	35.5	3.46	.61	.79	.95	9.8	33.5	3.96	.63	.81	.98	9.2	31.4	4.58	.64	.85	1.00	9.2	31.4	4.58	.64	.85	1.00
22°C (71°F)	.47	1000	11.2	38.1	3.05	.41	.54	.66	10.7	36.4	3.48	.41	.54	.67	10.1	34.4	3.99	.42	.55	.69	9.4	32.2	4.60	.42	.57	.71	9.4	32.2	4.60	.42	.57	.71
	.56	1200	11.4	39.0	3.07	.42	.56	.70	10.9	37.2	3.50	.42	.57	.72	10.3	35.1	4.01	.43	.58	.74	9.6	32.9	4.63	.44	.60	.77	9.6	32.9	4.63	.44	.60	.77
	.66	1400	11.6	39.7	3.08	.43	.59	.74	11.0	37.7	3.51	.44	.60	.76	10.4	35.6	4.03	.44	.61	.79	9.8	33.3	4.64	.45	.64	.82	9.8	33.3	4.64	.45	.64	.82

HS40-036 — CB29M-51 COOLING CAPACITY

Entering Wet Bulb Temperature	Total Air Volume		Outdoor Air Temperature Entering Outdoor Coil																													
			29°C (85°F)						35°C (95°F)						41°C (105°F)						46°C (115°F)											
			Total Cooling Capacity		Comp Motor kW Input		Sensible To Total Ratio (S/T)			Total Cooling Capacity		Comp Motor kW Input		Sensible To Total Ratio (S/T)			Total Cooling Capacity		Comp Motor kW Input		Sensible To Total Ratio (S/T)			Total Cooling Capacity		Comp Motor kW Input		Sensible To Total Ratio (S/T)				
							Dry Bulb							Dry Bulb							Dry Bulb							Dry Bulb				
m³/s	cfm	kW	kBtuh	24°C 75°F	27°C 80°F	29°C 85°F	kW	kBtuh	Input	24°C 75°F	27°C 80°F	29°C 85°F	kW	kBtuh	Input	24°C 75°F	27°C 80°F	29°C 85°F	kW	kBtuh	Input	24°C 75°F	27°C 80°F	29°C 85°F	kW	kBtuh	Input	24°C 75°F	27°C 80°F	29°C 85°F		
17°C (63°F)	.47	1000	10.6	36.0	3.03	.69	.85	.99	10.0	34.0	3.45	.70	.88	1.00	9.4	32.0	3.96	.72	.92	1.00	8.7	29.7	4.56	.75	.96	1.00	8.7	29.7	4.56	.75	.96	1.00
	.56	1200	10.9	37.1	3.05	.73	.92	1.00	10.3	35.1	3.48	.75	.95	1.00	9.7	33.0	3.98	.78	.99	1.00	9.1	30.9	4.59	.83	1.00	1.00	9.1	30.9	4.59	.83	1.00	1.00
	.66	1400	11.2	38.1	3.07	.78	.98	1.00	10.6	36.2	3.50	.81	1.00	1.00	10.0	34.2	4.01	.85	1.00	1.00	9.4	32										

RATINGS – 50HZ

NOTE For Temperatures and Capacities not shown, see bulletin — Cooling Unit Rating Table Correction Factor Data in Miscellaneous Engineering Data Section. All values are gross capacities and do not include evaporator coil blower motor heat deduction.

HS40-048 — CB29M-31/41 COOLING CAPACITY

Entering Wet Bulb Temperature	Total Air Volume		Outdoor Air Temperature Entering Outdoor Coil																													
			29°C (85°F)						35°C (95°F)						41°C (105°F)						46°C (115°F)											
			Total Cooling Capacity		Comp Motor kW Input	Sensible To Total Ratio (S/T)			Total Cooling Capacity		Comp Motor kW Input	Sensible To Total Ratio (S/T)			Total Cooling Capacity		Comp Motor kW Input	Sensible To Total Ratio (S/T)			Total Cooling Capacity		Comp Motor kW Input	Sensible To Total Ratio (S/T)								
						Dry Bulb						Dry Bulb						Dry Bulb						Dry Bulb								
m³/s	cfm	kW	kBtuh	24°C 75°F	27°C 80°F	29°C 85°F	kW	kBtuh	Input	24°C 75°F	27°C 80°F	29°C 85°F	kW	kBtuh	Input	24°C 75°F	27°C 80°F	29°C 85°F	kW	kBtuh	Input	24°C 75°F	27°C 80°F	29°C 85°F								
17°C (63°F)	.59	1250	12.0	41.0	3.64	.71	.86	.98	11.4	39.0	4.17	.72	.88	.99	10.8	36.8	4.77	.74	.91	1.00	10.9	37.3	4.78	.77	.93	1.00	10.2	34.9	5.48	.79	.96	1.00
	.63	1350	12.2	41.5	3.66	.72	.88	1.00	11.5	39.4	4.18	.74	.91	1.00	10.9	37.3	4.78	.77	.93	1.00	10.2	34.9	5.48	.79	.96	1.00	10.3	35.3	5.49	.82	.98	1.00
	.68	1450	12.3	41.9	3.67	.74	.91	1.00	11.7	39.9	4.19	.76	.93	1.00	11.0	37.7	4.80	.78	.95	1.00	10.3	35.3	5.49	.82	.98	1.00	10.6	36.3	5.52	.85	.99	1.00
19°C (67°F)	.59	1250	12.7	43.5	3.70	.55	.68	.82	12.1	41.3	4.22	.56	.70	.85	11.4	38.9	4.83	.57	.72	.87	10.6	36.3	5.52	.58	.75	.91	10.6	36.7	5.53	.60	.77	.93
	.63	1350	12.9	43.9	3.71	.56	.70	.85	12.2	41.7	4.23	.57	.72	.87	11.5	39.3	4.84	.58	.74	.90	10.8	36.7	5.53	.60	.77	.93	10.8	37.0	5.54	.61	.79	.96
	.68	1450	13.0	44.3	3.72	.57	.71	.87	12.3	42.0	4.24	.58	.74	.90	11.6	39.6	4.85	.59	.76	.93	10.8	37.0	5.54	.61	.79	.96	11.0	37.7	5.57	.63	.80	.96
22°C (71°F)	.59	1250	13.6	46.3	3.77	.41	.53	.66	12.9	43.9	4.30	.41	.54	.68	12.1	41.4	4.90	.42	.56	.70	11.3	38.7	5.61	.42	.57	.72	11.4	39.0	5.62	.43	.59	.74
	.63	1350	13.7	46.7	3.78	.42	.54	.68	13.0	44.3	4.31	.42	.56	.70	12.3	41.8	4.92	.42	.57	.72	11.4	39.0	5.62	.43	.59	.74	11.6	39.6	5.63	.44	.60	.77
	.68	1450	13.8	47.1	3.79	.42	.56	.69	13.1	44.7	4.32	.42	.57	.71	12.3	42.1	4.93	.43	.58	.74	11.5	39.3	5.63	.43	.60	.77	11.8	40.2	5.64	.44	.61	.78

HS40-048 — CB29M-51 COOLING CAPACITY

Entering Wet Bulb Temperature	Total Air Volume		Outdoor Air Temperature Entering Outdoor Coil																													
			29°C (85°F)						35°C (95°F)						41°C (105°F)						46°C (115°F)											
			Total Cooling Capacity		Comp Motor kW Input	Sensible To Total Ratio (S/T)			Total Cooling Capacity		Comp Motor kW Input	Sensible To Total Ratio (S/T)			Total Cooling Capacity		Comp Motor kW Input	Sensible To Total Ratio (S/T)			Total Cooling Capacity		Comp Motor kW Input	Sensible To Total Ratio (S/T)								
						Dry Bulb						Dry Bulb						Dry Bulb						Dry Bulb								
m³/s	cfm	kW	kBtuh	24°C 75°F	27°C 80°F	29°C 85°F	kW	kBtuh	Input	24°C 75°F	27°C 80°F	29°C 85°F	kW	kBtuh	Input	24°C 75°F	27°C 80°F	29°C 85°F	kW	kBtuh	Input	24°C 75°F	27°C 80°F	29°C 85°F	kW	kBtuh	Input	24°C 75°F	27°C 80°F	29°C 85°F		
17°C (63°F)	.66	1400	13.6	46.5	3.84	.72	.87	.99	13.0	44.2	4.39	.74	.89	1.00	12.3	41.8	5.00	.76	.92	1.00	11.5	39.2	5.72	.78	.95	1.00	11.8	40.2	5.76	.83	.99	1.00
	.75	1600	13.9	47.5	3.87	.75	.91	1.00	13.2	45.2	4.41	.77	.94	1.00	12.5	42.7	5.03	.80	.96	1.00	11.8	40.2	5.76	.83	.99	1.00	12.0	41.1	5.79	.87	1.00	1.00
	.85	1800	14.2	48.4	3.89	.79	.95	1.00	13.5	46.1	4.43	.81	.97	1.00	12.8	43.6	5.06	.83	.99	1.00	12.0	41.1	5.79	.87	1.00	12.4	42.0	5.82	.90	1.00	1.00	
19°C (67°F)	.66	1400	14.4	49.3	3.91	.56	.70	.84	13.7	46.9	4.46	.57	.71	.86	13.0	44.2	5.08	.58	.73	.89	12.1	41.4	5.80	.60	.76	.92	12.1	41.4	5.80	.60	.76	.92
	.75	1600	14.7	50.2	3.94	.58	.73	.88	14.0	47.7	4.48	.59	.75	.91	13.2	45.0	5.11	.60	.77	.93	12.3	42.0	5.84	.62	.80	.96	12.3	42.0	5.84	.62	.80	.96
	.85	1800	14.9	50.9	3.95	.60	.76	.92	14.2	48.3	4.50	.61	.79	.95	13.4	45.6	5.13	.63	.81	.97	12.5	42.6	5.85	.64	.84	.99	12.5	42.6	5.85	.64	.84	.99
22°C (71°F)	.66	1400	15.4	52.6	4.00	.42	.54	.67	14.6	49.9	4.55	.42	.56	.69	13.8	47.1	5.18	.43	.57	.71	12.9	44.1	5.91	.43	.58	.73	12.9	44.1	5.91	.43	.58	.73
	.75	1600	15.6	53.4	4.02	.43	.57	.71	14.9	50.7	4.57	.43	.58	.73	14.0	47.8	5.21	.43	.59	.75	13.1	44.7	5.93	.44	.61	.78	13.1	44.7	5.93	.44	.61	.78
	.85	1800	15.9	54.1	4.04	.43	.59	.74	15.0	51.3	4.59	.44	.60	.76	14.2	48.4	5.22	.44	.62	.79	13.2	45.2	5.95	.45	.64	.82	13.2	45.2	5.95	.45	.64	.82

HS40-065 — CB29M-51 COOLING CAPACITY

Entering Wet Bulb Temperature	Total Air Volume		Outdoor Air Temperature Entering Outdoor Coil																													
			29°C (85°F)						35°C (95°F)						41°C (105°F)						46°C (115°F)											
			Total Cooling Capacity		Comp Motor kW Input	Sensible To Total Ratio (S/T)			Total Cooling Capacity		Comp Motor kW Input	Sensible To Total Ratio (S/T)			Total Cooling Capacity		Comp Motor kW Input	Sensible To Total Ratio (S/T)			Total Cooling Capacity		Comp Motor kW Input	Sensible To Total Ratio (S/T)								
						Dry Bulb						Dry Bulb						Dry Bulb						Dry Bulb								
m³/s	cfm	kW	kBtuh	24°C 75°F	27°C 80°F	29°C 85°F	kW	kBtuh	Input	24°C 75°F	27°C 80°F	29°C 85°F	kW	kBtuh	Input	24°C 75°F	27°C 80°F	29°C 85°F	kW	kBtuh	Input	24°C 75°F	27°C 80°F	29°C 85°F	kW	kBtuh	Input	24°C 75°F	27°C 80°F	29°C 85°F		
17°C (63°F)	.80	1700	16.4	56.0	4.64	.71	.87	.98	15.7	53.5	5.24	.73	.89	1.00	14.9	50.9	5.92	.75	.91	1.00	14.2	48.4	6.69	.77	.93	1.00	14.3	48.9	6.71	.78	.95	1.00
	.85	1800	16.6	56.6	4.66	.73	.88	.99	15.8	54.0	5.26	.74	.90	1.00	15.1	51.4	5.93	.76	.93	1.00	14.3	48.9	6.71	.78	.95	1.00	14.5	49.4	6.72	.80	.96	1.00
	.89	1900	16.7	57.0	4.67	.74	.90	1.00	15.9	54.4	5.27	.76	.92	1.00	15.2	51.9	5.96	.78	.94	1.00	14.5	49.4	6.72	.80	.96	1.00	14.7	50.0	6.73	.81	.97	1.00
19°C (67°F)	.80	1700	17.4	59.5	4.74	.56	.69	.83	16.6	56.7	5.34	.57	.71	.85	15.8	53.9	6.02	.58	.72	.87	15.0	51.2	6.79	.58	.74	.90	15.0	51.2	6.79	.58	.74	.90
	.85	1800	17.6	59.9	4.75	.56	.70	.85	16.7	57.1	5.35	.57	.72	.87	15.9	54.3	6.04	.58	.74	.89	15.1	51.5	6.81	.59	.76	.92	15.1	51.5	6.81	.59	.76	.92
	.89	1900	17.7	60.3	4.76	.57	.72	.87	16.9	57.5	5.36	.58	.73	.89	16.0	54.7	6.04	.59	.75	.91	15.2	51.8	6.83	.60	.78	.94	15.2	51.8	6.83	.60	.78	.94
22°C (71°F)	.80	1700	18.6	63.3	4.85	.42	.54	.67	17.7	60.4	5.46	.42	.55	.68	16.8	57.4	6.15	.42	.56	.70	16.0	54.5	6.94	.43	.57	.72	16.0	54.5	6.94	.43	.57	.72
	.85	1800	18.7	63.7	4.86	.42	.55	.68	17.8	60.8	5.47	.42	.56	.70	16.9	57.8	6.16	.43	.57	.71	16.1	54.9	6.95	.43	.58	.73	16.1	54.9	6.95	.43	.58	.73
	.89	1900	18.8	64.1	4.87	.42	.56	.69	17.9	61.1	5.48	.42	.57	.71	17.0	58.1	6.18	.43	.58	.73	16.2	55.2	6.96	.43	.59	.75	16.2	55.2	6.96	.43	.59	.75

HS40-065 — CB29M-65 COOLING CAPACITY

Entering Wet Bulb Temperature	Total Air Volume		Outdoor Air Temperature Entering Outdoor Coil																													
			29°C (85°F)						35°C (95°F)						41°C (105°F)						46°C (115°F)											
			Total Cooling Capacity		Comp Motor kW Input	Sensible To Total Ratio (S/T)			Total Cooling Capacity		Comp Motor kW Input	Sensible To Total Ratio (S/T)			Total Cooling Capacity		Comp Motor kW Input	Sensible To Total Ratio (S/T)			Total Cooling Capacity		Comp Motor kW Input	Sensible To Total Ratio (S/T)								
						Dry Bulb						Dry Bulb						Dry Bulb						Dry Bulb								
m³/s	cfm	kW	kBtuh	24°C 75°F	27°C 80°F	29°C 85°F	kW	kBtuh	Input	24°C 75°F	27°C 80°F	29°C 85°F	kW	kBtuh	Input	24°C 75°F	27°C 80°F	29°C 85°F	kW	kBtuh	Input	24°C 75°F	27°C 80°F	29°C 85°F	kW	kBtuh	Input	24°C 75°F	27°C 80°F	29°C 85°F		
17°C (63°F)	.85	1800	17.0	58.0	4.66	.69	.86	.99	16.2	55.4	5.26	.71	.89	1.00	15.4	52.7	5.94	.72	.91	1.00	14.7	50.2	6.71	.75	.94	1.00	14.7	50.2	6.71	.75	.94	1.00
	.94	2000	17.3	59.0	4.69	.72	.90	1.00	16.5	56.3	5.29	.74	.92	1.00	15.7	53.6	5.98	.76	.95	1.00	15.0	51.1	6.74	.78	.97	1.00	15.0	51.1	6.74	.78	.97	1.00
	1.04	2200	17.6	59.9	4.72	.74	.93	1.00	16.7	57.1	5.32	.77	.96	1.00	16.0	54.5	6.00	.79	.98	1.00	15.2	52.0	6.78	.82	.99	1.00	15.2</					