

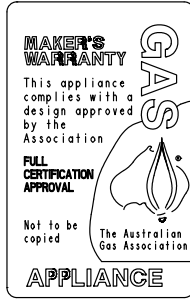

© 2006 Lennox Industries Inc.
Dallas, Texas, USA



INSTALLATION INSTRUCTIONS

G61MPVT SERIES UNITS

GAS UNITS
505,187M
01/2010

TP Technical
Publications
Litho U.S.A.

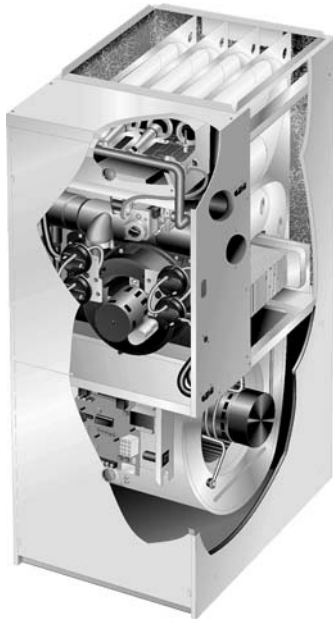

**RETAIN THESE INSTRUCTIONS
FOR FUTURE REFERENCE**

Table of Contents

Unit Dimensions	2
G61MPVT Parts Arrangement	3
Shipping and Packing List	4
Safety Information	4
Installation - Setting Equipment	5
Filters	9
Duct System	9
Pipe & Fittings Specifications	10
Vent Piping Guidelines	11
Joint Cementing Procedure	12
Venting Practices	13
Gas Piping	21
Electrical	23
Integrated Control Board	27
Unit Start-Up	34
Gas Pressure Adjustment	35
Manifold Pressure & High Altitude Information	35
Other Unit Adjustments	36
Heating Sequence of Operation	37
Service	38
Requirements	40
General	40
Combustion, Dilution & Ventilation Air	41
Ignition Control Board Diagnostic Codes	44
Troubleshooting	45
Repair Parts List	51
Vent Pipe Sizing Worksheet	51
Start-Up & Performance Check List	52



! WARNING

FIRE OR EXPLOSION HAZARD.



Failure to follow safety warnings exactly could result in serious injury, death, or property damage.

Do not store or use gasoline or other flammable vapors and liquids in the vicinity of this or any other appliance.

Installation and service must be performed by a qualified installer, service agency or the gas supplier.

WHAT TO DO IF YOU SMELL GAS:

- **Do not try to light any appliance.**
- **Do not touch any electrical switch; do not use any phone in your building.**
- **Leave the building immediately.**
- **Immediately call your gas supplier from a neighbor's phone. Follow the gas supplier's instructions.**
- **If you cannot reach your gas supplier, call the fire department.**



G61MPVT Unit Dimensions - mm

*60C and 60D size units installed in upflow applications that require air volumes over 1800 cfm (850 L/s) must have one of the following:

1. Single side return air with transition, to accommodate 20 x 25 x 1 in. (508 x 635 x 25 mm) air filter. Required to maintain proper air velocity.
2. Single side return
3. Bottom return air.
4. Return air from both sides.
5. Bottom and one side return air.

Refer to Engineering Handbook for additional information.

**Consider sizing requirements for optional IAQ equipment before cutting side return opening.

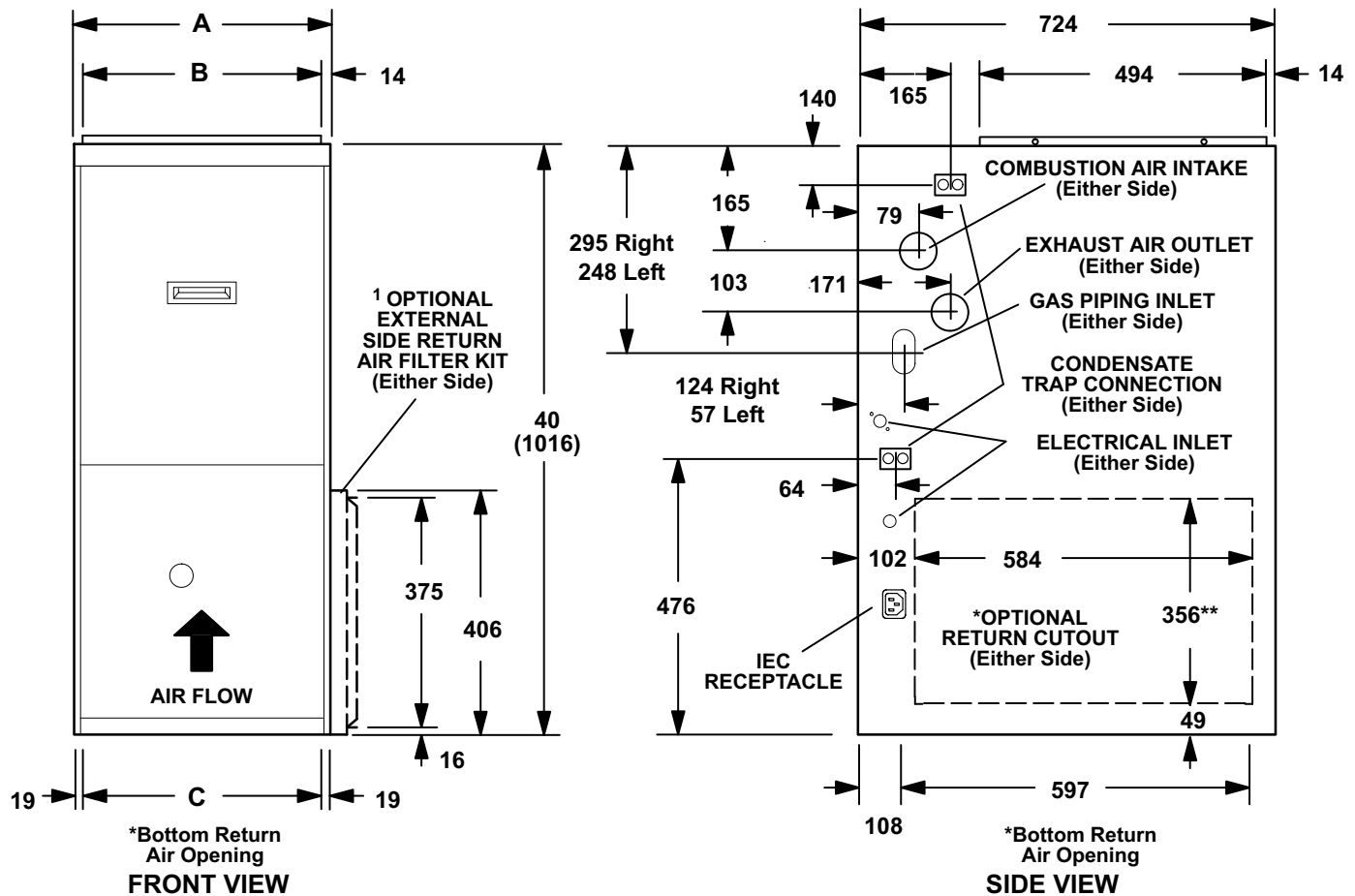
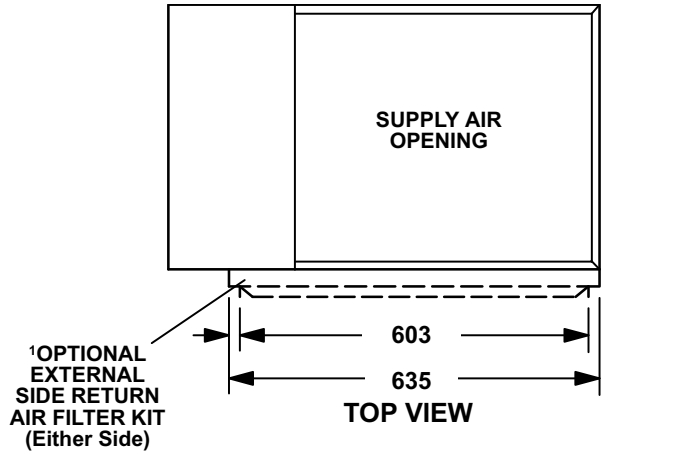

Model No.	A	B	C
	mm	mm	mm
G61MPVT-36B-070	446	416	406
G61MPVT-60C-090 G61MPVT-60C-110	533	454	495
G61MPVT-60D-135	622	594	584

G61MPVT Parts Arrangement

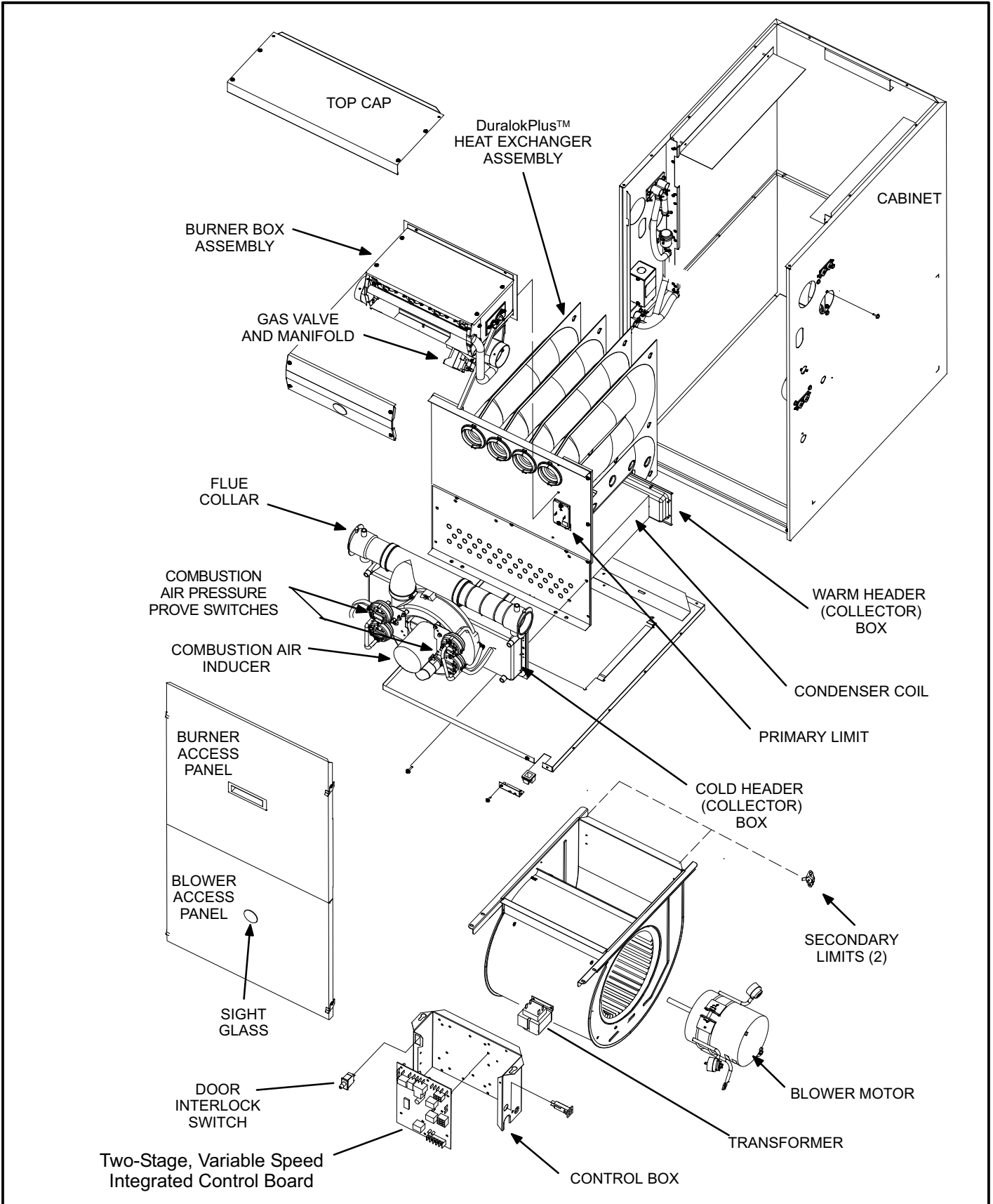

FIGURE 1

G61MPVT Gas Furnace

The G61MPVT gas furnace is equipped with a two-stage, variable speed integrated control. This control ensures compatibility with a thermostat which provides humidity control. Each G61MPVT is shipped ready for installation in the upflow, downflow, horizontal left air discharge or horizontal right air discharge position. The furnace is shipped with the bottom panel in place. The bottom panel must be removed if the unit is to be installed in upflow applications with bottom return air. The bottom panel must also be removed and discarded in all downflow or horizontal applications.

The furnace is equipped for installation in natural gas applications. A conversion kit (ordered separately) is required for use in propane/LP gas applications.

All G61MPVT models can be installed as a Direct Vent gas central furnace. G61MPVT-070, -090 and -110 models can be installed as a Non-Direct Vent gas central furnace.

NOTE - In Direct Vent installations, combustion air is taken from outdoors and flue gases are discharged outdoors. In Non-Direct Vent installations, combustion air is taken from indoors and flue gases are discharged outdoors. See figure 2 for applications involving roof termination.

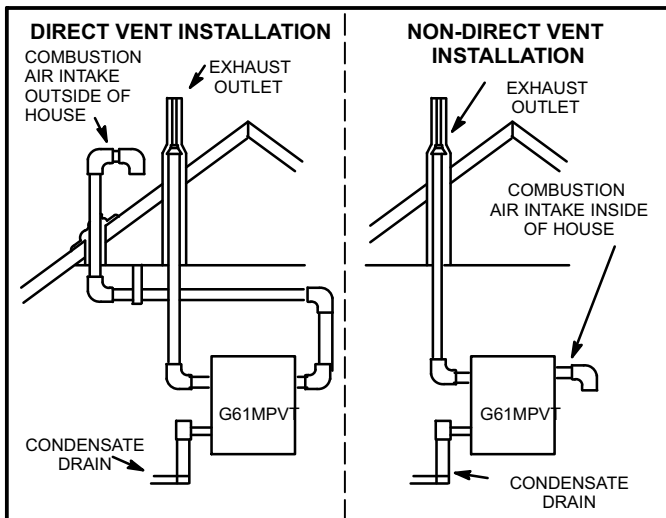

FIGURE 2

Shipping and Packing List

Package 1 of 1 contains

- 1 - Assembled G61MPVT unit
- 1 - Bag assembly containing the following:
 - 3 - Screws
 - 3 - Wire nuts
 - 1 - Snap bushing
 - 1 - Snap plug
 - 1 - Wire tie
 - 1 - Condensate trap
 - 1 - Condensate trap cap
 - 2 - 2" diameter vent / intake plugs
 - 1 - 3" diameter cabinet plug (intake)
 - 2 - 2" diameter debris screen
- 1 - Bag assembly containing the following:
 - 1 - 50 hertz power wiring harness

NOTE - G61MPVT-60C-110 and -60D-135 units also include two 50mm to 80mm diameter ABS street elbows and two 80mm to 50mm ABS reducing elbows, which are shipped on the blower deck in the heating compartment.

The following items may also be ordered separately:

- 1 - Thermostat
- 1 - Propane/LP changeover kit

Check equipment for shipping damage. If you find any damage, immediately contact the last carrier.

Safety Information

⚠ WARNING

Improper installation, adjustment, alteration, service or maintenance can cause property damage, personal injury or loss of life. Installation and service must be performed by a qualified installer, service agency or the gas supplier.

⚠ CAUTION

As with any mechanical equipment, personal injury can result from contact with sharp sheet metal edges. Be careful when you handle this equipment.

Installation - Setting Equipment

⚠ WARNING

Do not install the furnace on its front or its back. Do not connect the return air ducts to the back of the furnace. Doing so will adversely affect the operation of the safety control devices, which could result in personal injury or death.

Select a location that allows for the required clearances that are listed on the unit nameplate. Also consider gas supply connections, electrical supply, vent connection, condensate trap and drain connections, and installation and service clearances [610 mm (24 inches) at unit front]. *The unit must be level from front to back and side to side.*

*NOTE - G61MPVT-36B units with 1/2 hp blower motors are equipped with three flexible legs and one rigid leg. The rigid leg is equipped with a shipping bolt and a flat white plastic washer (rather than the rubber mounting grommet used with a flexible mounting leg). **The bolt and washer must be removed before the furnace is placed into operation.** After the bolt and washer have been removed, the rigid leg will not touch the blower housing.*

NOTE - G61MPVT-60D-135 units are equipped with a shipping pad under the blower housing. Remove the shipping pad prior to operation.

Allow for clearances to combustible materials as indicated on the unit nameplate. Minimum clearances for closet or alcove installations are shown in figures 3, 9 and 6.

⚠ WARNING

Blower access panel must be securely in place when blower and burners are operating. Gas fumes, which could contain carbon monoxide, can be drawn into living space resulting in personal injury or death.

⚠ WARNING

Improper installation of the furnace can result in personal injury or death. Combustion and flue products must never be allowed to enter the return air system or air in the living space. Use sheet metal screws and joint tape to seal return air system to furnace. In platform installations with furnace return, the furnace should be sealed airtight to the return air plenum. A door must never be used as a portion of the return air duct system. The base must provide a stable support and an airtight seal to the furnace. Allow absolutely no sagging, cracks, gaps, etc. For no reason should return and supply air duct systems ever be connected to or from other heating devices such as a fireplace or stove, etc. Fire, explosion, carbon monoxide poisoning, personal injury and/or property damage could result.

Upflow Applications

The G61MPVT gas furnace can be installed as shipped in the upflow position. Refer to figure 3 for clearances.

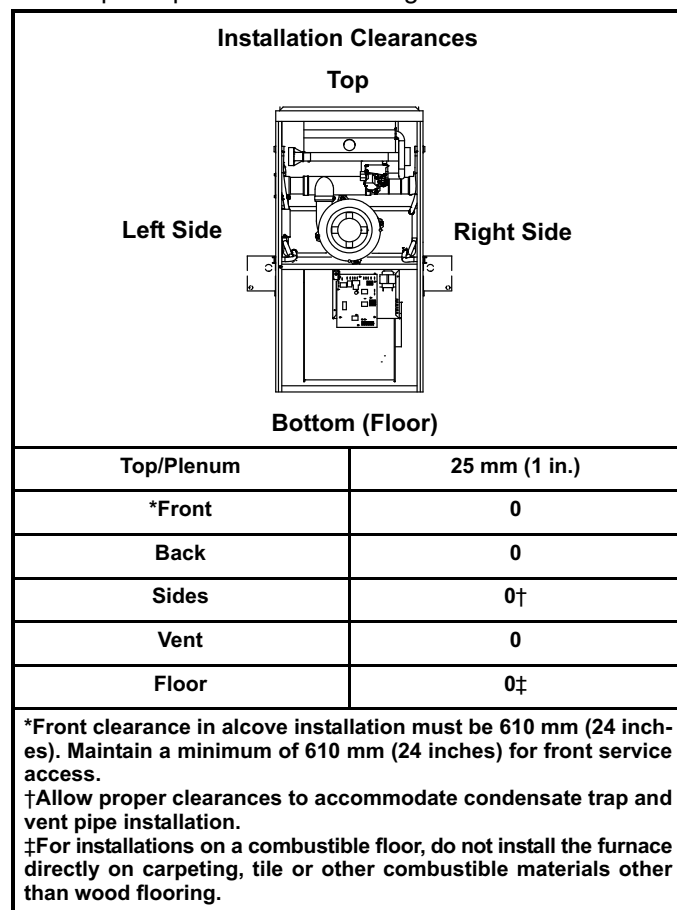

FIGURE 3

Return Air -- Upflow Units

NOTE - G61MPVT-135 models are not approved for installation in upflow air discharge applications.

Return air can be brought in through the bottom or either side of the furnace installed in an upflow application. If the furnace is installed on a platform with bottom return, make an airtight seal between the bottom of the furnace and the platform to ensure that the furnace operates properly and safely. The furnace is equipped with a removable bottom panel to facilitate installation.

Markings are provided on both sides of the furnace cabinet for installations that require side return air. Cut the furnace cabinet at the maximum dimensions shown on page 2.

NOTE - When air volumes over 850 L/s (1800 cfm) are required with 60C or 60D models in an upflow application, the following return air options are available:

- 1 - Return air from single side with transition which will accommodate 508 x 635 x 25 mm (20 x 25 x 1 in.) air filter. (Required to maintain proper air velocity.) See figure 4.
- 2 - Return air from single side.
- 3 - Return air from bottom.
- 4 - Return air from both sides.

5 - Return air from bottom and one side.
 Refer to Engineering Handbook for additional information.
G61MPVT applications which include side return air and a condensate trap installed on the same side of the cabinet require either a return air base or field-fabricated transition to accommodate an optional IAQ accessory taller than 368mm (14.5 inches).

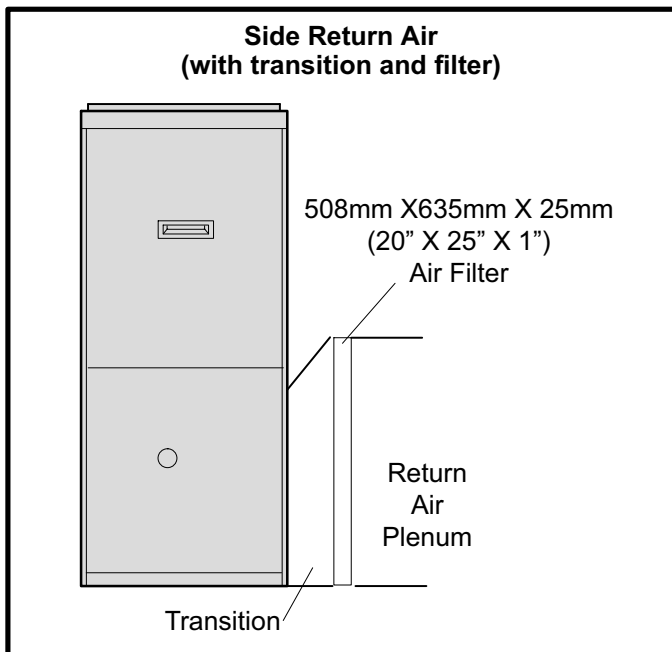

**FIGURE 4
Removing the Bottom Panel**

Remove the two screws that secure the bottom cap to the furnace. Pivot the bottom cap down to release the bottom panel. Once the bottom panel has been removed, reinstall the bottom cap. See figure 5.

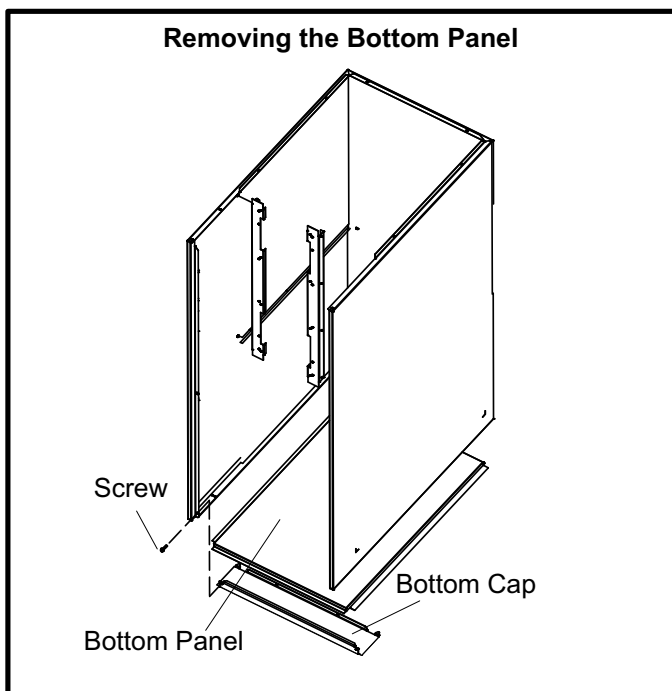

FIGURE 5

Horizontal Applications

G61MPVT furnaces, with the exception of the G61MPVT-60D-135, can be installed in horizontal applications with either right- or left-hand air discharge. The G61MPVT-60D-135 can only be installed in horizontal applications with right-hand air discharge. Refer to figure 6 for clearances in horizontal applications.

**Horizontal Application
Installation Clearances**

**Right-Hand Discharge
Top**

Left End Right End

Bottom (Floor)**

**Left-Hand Discharge
Top**

Left End Right End

Bottom (Floor)**

Top	0
Front*	0
Back	0
Ends	0
Vent	0
Floor	0‡

*Front clearance in alcove installation must be 610 mm (24 inches). Maintain a minimum of 610mm (24 inches) for front service access.
 **A 140mm (5-1/2") service clearance must be maintained below the unit to provide for servicing of the condensate trap.
 ‡For installations on a combustible floor, do not install the furnace directly on carpeting, tile or other combustible materials other than wood flooring.

FIGURE 6

This furnace may be installed in either a roof space or under floor. Install the furnace on a field-fabricated raised platform, as shown in figure 7. The unit must be supported at both ends and beneath the blower deck to prevent sagging.

NOTE - In horizontal applications, the unit must be level side-to-side. The unit may be tilted back-to-front a maximum of 25mm (1 inch) to ensure proper draining of the heat exchanger. The heat exchanger coil will not drain properly if the unit is tilted backward.

TYPICAL HORIZONTAL ROOF SPACE INSTALLATION (FORCED AIR FURNACE)

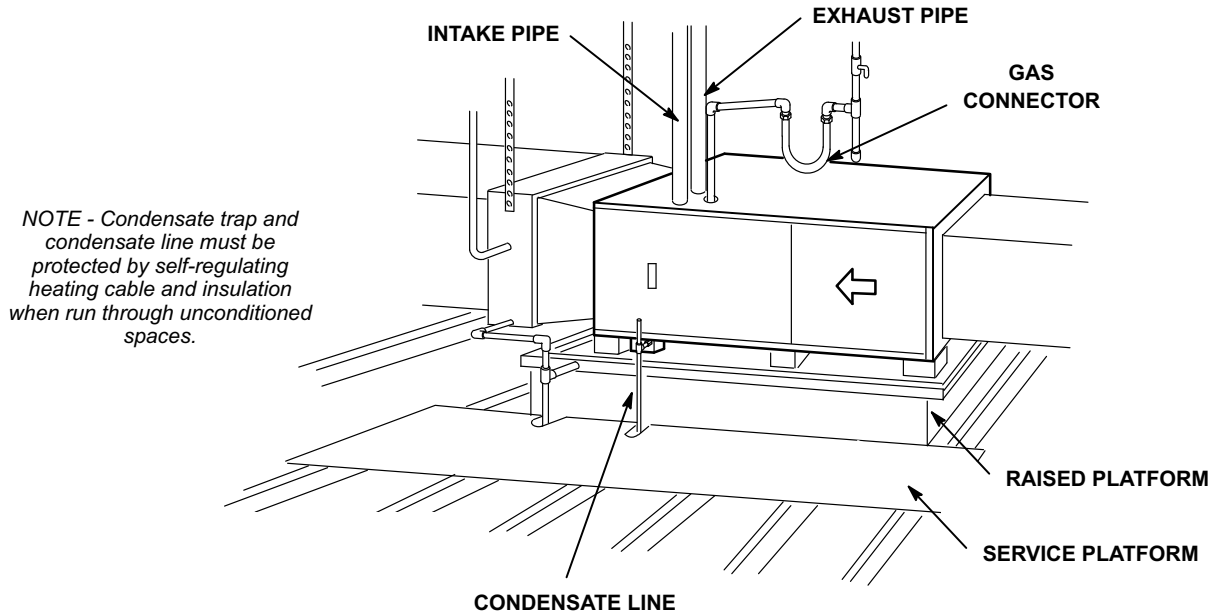

FIGURE 7

Platform Installation of Horizontal Unit in Roof Space

- 1 - Select location for unit keeping in mind service and other necessary clearances. See figure 6.
- 2 - Construct a raised wooden frame and cover frame with a plywood sheet. Provide a service platform for unit. A drain pan is also recommended.
- 3 - Route auxiliary drain line so that water draining from this outlet will be easily noticed by the homeowner.
- 4 - Set unit in drain pan (if used) as shown in figure 7. Unit must be level to ensure proper coil drainage. Leave 140mm (5-1/2 inches) for service clearance below unit for condensate trap.
- 5 - Continue with exhaust, condensate and intake piping installation according to instructions.

Platform Installation of Horizontal Unit Installed Under Floor

- 1 - Select location for unit, keeping in mind service and other clearances.

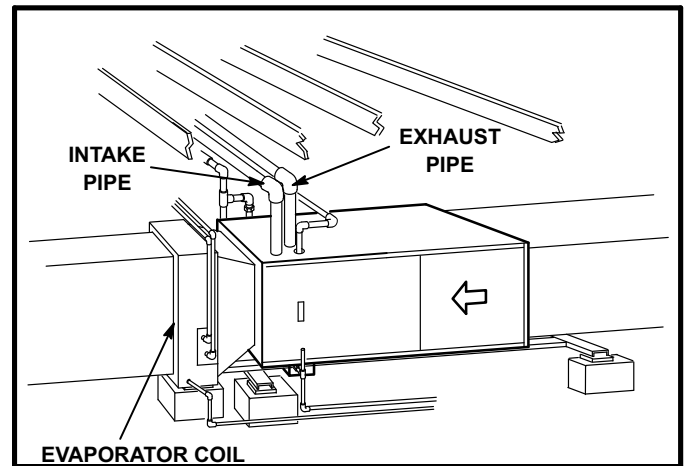

FIGURE 8

- 2 - After positioning cement blocks, mount support frame on top of blocks and install unit. Unit must be level to ensure proper heat exchanger coil drainage. Leave 140mm (5-1/2 inches) for service clearance) for condensate trap.
- 3 - Install exhaust and intake piping according to information given in following section.

Return Air -- Horizontal Applications

Return air may be brought in only through the end of a furnace installed in the horizontal position. The furnace is equipped with a removable bottom panel to facilitate installation. See figure 5.

Downflow Applications

The unit may be installed three ways in downflow applications: on non-combustible flooring, on combustible flooring using an additive base, or on a reverse-flow cooling cabinet. **Do not drag the unit across the floor in the downflow position. Flange damage will result.**

Refer to figure 9 for clearances in downflow applications.

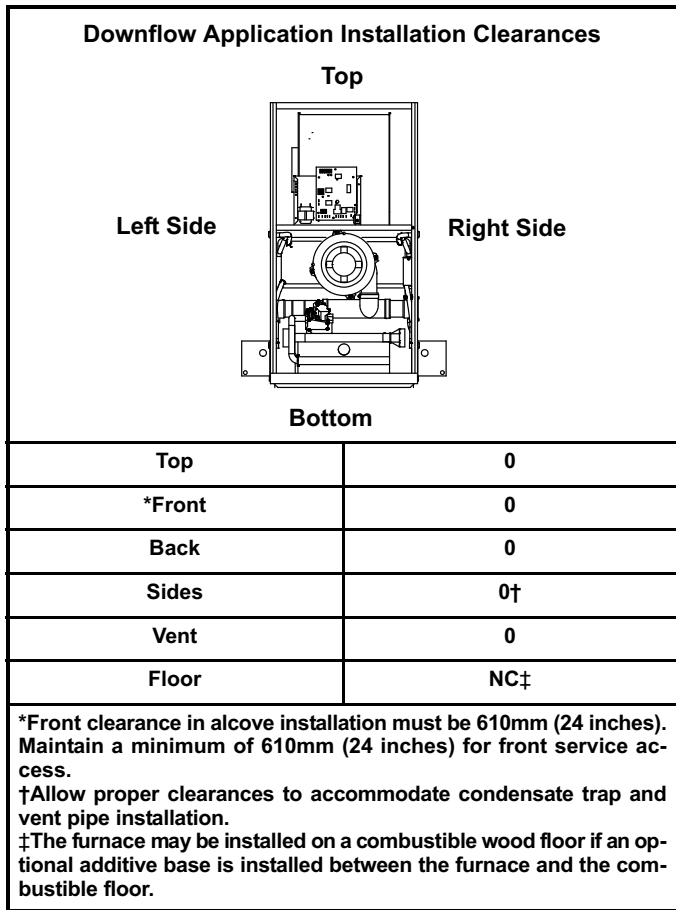

FIGURE 9

Installation on Non-Combustible Flooring

- 1 - Cut floor opening keeping in mind clearances listed on unit rating plate. Also keep in mind gas supply connections, electrical supply, flue and air intake connections and sufficient installation and servicing clearances. See table 1 for correct floor opening size.
- 2 - Flange warm air plenum and lower the plenum into the opening.

- 3 - Set the unit over the plenum and seal the plenum to the unit.
- 4 - Ensure that the seal is adequate.

**TABLE 1
NON-COMBUSTIBLE FLOOR OPENING SIZE**

Model No.	Front to Rear		Side to Side	
	in.	mm	in.	mm
B Cabinet (445mm)	19 - 3/4	502	16 - 5/8	422
C Cabinet (533mm)	19 - 3/4	502	20-1/8	511
D Cabinet (622mm)	19 - 3/4	502	23 - 5/8	600

NOTE - Floor opening dimensions listed are 1/4 inch (6 mm) larger than the unit opening. See dimension drawing on page 2.

Installation on Combustible Flooring

- 1 - When unit is installed on a combustible floor, an additive base must be installed between the furnace and the floor. The base must be ordered separately for the following cabinet sizes:
 - B cabinet 445mm - # 11M60
 - C cabinet 533mm - # 11M61
 - D cabinet 622mm - # 11M62
- See table 2 for opening size to cut in floor.

⚠ CAUTION

The furnace and additive base shall not be installed directly on carpeting, tile, or other combustible material other than wood flooring.

**TABLE 2
ADDITIVE BASE FLOOR OPENING SIZE**

Model	Front to Rear		Side to Side	
	in.	mm	in.	mm
B Cabinet (445mm)	22	559	18 - 3/4	476
C Cabinet (533mm)	22	559	22 - 3/4	578
D Cabinet (622mm)	22	559	25 - 3/4	654

- 2 - After opening is cut, set additive base into opening.
- 3 - Check fiberglass strips on additive base to make sure they are properly glued and positioned.
- 4 - Lower supply air plenum into additive base until plenum flanges seal against fiberglass strips.

NOTE - Be careful not to damage fiberglass strips. Check for a tight seal.
- 5 - Set the furnace over the plenum.
- 6 - Ensure that the seal between the furnace and plenum is adequate.

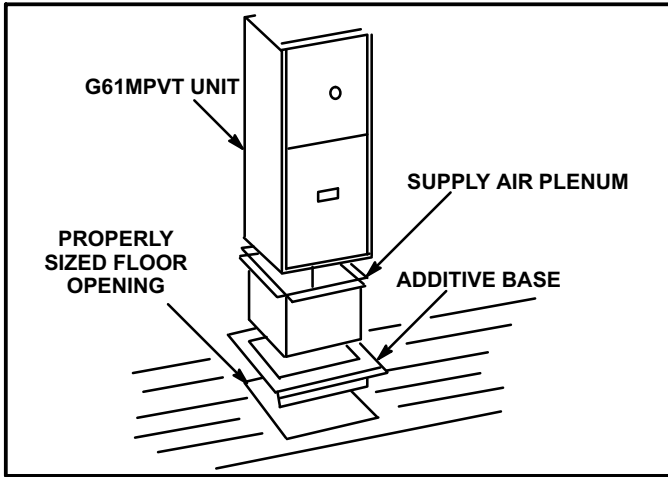

FIGURE 10

Installation on Cooling Cabinet

- 1 - Refer to reverse-flow coil installation instructions for correctly sized opening in floor and installation of cabinet.
- 2 - When cooling cabinet is in place, set and secure the furnace according to the instructions that are provided with the cooling coil. Secure the furnace to the cabinet.
- 3 - Seal the cabinet and check for air leaks.

Return Air Opening -- Downflow Units

Return air may be brought in only through the top opening of a furnace installed in the downflow position. The following steps should be taken when installing plenum:

- 1 - Bottom edge of plenum should be flanged with a hemmed edge (See figure 11 or 12).
- 2 - Sealing strips should be used to ensure an airtight seal between the cabinet and the plenum.
- 3 - In all cases, plenum should be secured to top of furnace using sheet metal screws.
- 4 - Make certain that an adequate seal is made.

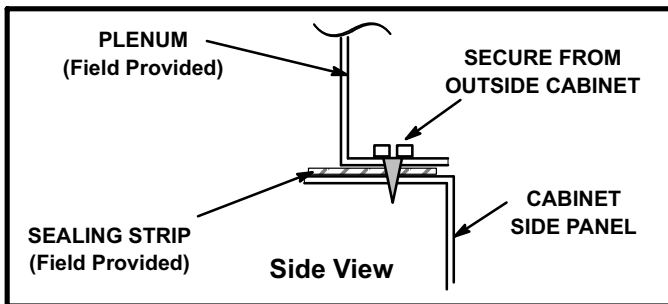

FIGURE 11

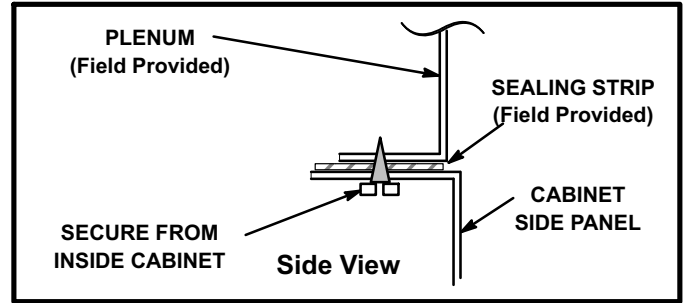

FIGURE 12

Filters

This unit is not equipped with a filter or rack. A field-provided filter is required for the unit to operate properly. Table 3 lists recommended minimum filter sizes.

A filter must be in place when the unit is operating.

NOTE - In upflow applications where side return air filter is installed on same side as the condensate trap, filter rack must be installed beyond condensate trap to avoid interference.

TABLE 3

Furnace Cabinet Size	Filter Size -- mm	
	Side Return	Bottom Return
445mm	406 X 635 X 25 (1)	406 X 635 X 25 (1)
533mm	406 X 635 X 25 (1)	508 X 635 X 25 (1)
622mm	406 X 635 X 25 (2)	610 X 635 X 25 (1)

Duct System

Use industry-approved standards to size and install the supply and return air duct system. This will result in a quiet and low-static system that has uniform air distribution.

NOTE - Operation of this furnace in heating mode (indoor blower operating at selected heating speed) with an external static pressure which exceeds 200 Pa (0.8 inches w.c.) may result in erratic limit operation.

Supply Air Plenum

If the furnace is installed without a cooling coil, a removable access panel should be installed in the supply air duct. The access panel should be large enough to permit inspection (either by smoke or reflected light) of the heat exchanger for leaks after the furnace is installed. If present, this access panel must always be in place when the furnace is operating and it must not allow leaks into the supply air duct system.

Return Air Plenum

Return air must not be drawn from a room where this furnace, or any other gas appliance (ie., a water heater), is installed. When return air is drawn from a room, a negative pressure is created in the room. If a gas appliance is operating in a room with negative pressure, the flue products can be pulled back down the vent pipe and

into the room. This reverse flow of the flue gas may result in incomplete combustion and the formation of carbon monoxide gas. This toxic gas might then be distributed throughout the house by the furnace duct system.

Return air can be brought in through the bottom or either side of the furnace. If a furnace with bottom return air is installed on a platform, make an airtight seal between the bottom of the furnace and the platform to ensure that the unit operates properly and safely. Use fiberglass sealing strips, caulking, or equivalent sealing method between the plenum and the furnace cabinet to ensure a tight seal. If a filter is installed, size the return air duct to fit the filter frame.

Pipe & Fittings Specifications

All pipe and fittings to be Pressure Pipe, Class E / Class 12 / Schedule 40 or equivalent

All pipe, fittings, primer and solvent cement must conform

with Australian standards. The solvent shall be free flowing and contain no lumps, undissolved particles or any foreign matter that adversely affects the joint strength or chemical resistance of the cement. The cement shall show no gelation, stratification, or separation that cannot be removed by stirring.

⚠ CAUTION

Solvent cements for plastic pipe are flammable liquids and should be kept away from all sources of ignition. Do not use excessive amounts of solvent cement when making joints. Good ventilation should be maintained to reduce fire hazard and to minimize breathing of solvent vapors. Avoid contact of cement with skin and eyes.

Table 4 lists the available exhaust termination kits, as well as vent pipe equivalencies which must be used when sizing vent pipe. All Lennox vent terminations are PVC or ABS.

**TABLE 4
OUTDOOR TERMINATION KITS AND CORRESPONDING EQUIVALENCIES**

UNIT MODEL	VENT PIPE DIA. (in.)	Vent Pipe Length Equivalency (meters)								
		Outdoor Exhaust Accelerator (Dia. X Length)	Outdoor Exhaust Accelerator (Dia. X Length)	40mm (1-1/2") Concentric Kit	50mm (2") Concentric Kit	80mm (3") Concentric Kit	50mm (2") Wall Plate Kit	80mm (3") Wall Plate Kit	50mm (2") Wall Kit with Vent Extension	50mm (2") Wall Ring Kit
		40mm X 305mm	50mm X 305mm	71M80	60M29	60L46	22G44	44J40 81J20	30G28	15F74
-070	50mm	1.2	Not Allowed	3.6	Not Allowed	Not Allowed	4	4*	4	4
	80mm	2.4	Not Allowed	7.3	Not Allowed	Not Allowed	8	8*	8	8
	100mm	4.3	Not Allowed	12.8	Not Allowed	Not Allowed	14	14*	14	14
-090	50mm	Not Allowed	0.3	Not Allowed	.9	.9	Not Allowed	1	Not Allowed	1**
	80mm	Not Allowed	0.6	Not Allowed	1.8	1.8	Not Allowed	2	Not Allowed	2**
	100mm	Not Allowed	1.2	Not Allowed	3.7	3.7	Not Allowed	4	Not Allowed	4**
-110	80mm	Not Allowed	0.6	Not Allowed	1.8	1.8	Not Allowed	2	Not Allowed	2***
	100mm	Not Allowed	1.2	Not Allowed	3.7	3.7	Not Allowed	4	Not Allowed	4***
-135	80mm	Not Allowed	1.8	Not Allowed	Not Allowed	4.6	Not Allowed	6	Not Allowed	6***
	100mm	Not Allowed	3.0	Not Allowed	Not Allowed	7.6	Not Allowed	10	Not Allowed	10***

Vent Piping Guidelines

G61MPVT furnaces, with the exception of the G61MPVT-60D-135, can be installed as either a Non-Direct Vent or a Direct Vent gas central furnace. The G61MPVT-60D-135 can only be installed as a Direct Vent (two pipe) gas central furnace.

NOTE - In Non-Direct Vent installations, combustion air is taken from indoors and flue gases are discharged outdoors. In Direct Vent installations, combustion air is taken from outdoors and flue gases are discharged outdoors.

*Intake and exhaust pipe sizing in Direct Vent applications and exhaust pipe sizing in Non-Direct Vent applications -- Size pipe according to tables 5 and 6. Table 5 lists the *minimum* equivalent vent pipe lengths permitted. Table 6 lists the *maximum* equivalent pipe lengths permitted.*

Maximum vent length is defined as:

- Total length (linear meters) of pipe,
- Plus** Equivalent length (meters) of fittings,
- Plus** Equivalent length (meters) of termination.

NOTE - Include ALL pipe and ALL fittings, both in doors and outdoors.

Regardless of the diameter of pipe used, the standard roof and wall terminations described in section *Exhaust Piping Terminations* should be used. Exhaust vent termination pipe is sized to optimize the velocity of the exhaust gas as it exits the termination. Refer to table 7.

NOTE - The exhaust pipe should be offset a minimum of 305mm (12 inches) to avoid the possibility of water droplets being released from the exhaust termination. The minimum exhaust vent length is 4.5m (15 feet). Shorter exhaust vent lengths may result in the discharge of water droplets from the exhaust termination, in spite of the 305mm (12-inch) vertical offset.

Each 90° elbow (including those provided with the furnace) of any diameter is equivalent to 1.5m (5 feet) of vent pipe of the same diameter. Two 45° elbows are equivalent to one 90° elbow of the same diameter. One 45° elbow is equal to .76m (2.5 feet) of vent pipe of the same diameter.

In some applications which permit the use of several different sizes of vent pipe, a combination vent pipe may be used. Contact Lennox for assistance in sizing vent pipe in these applications.

NOTE - The flue collar on all models is sized to accommodate 50mm Schedule 40 / Class 12 / Class E pressure pipe. When vent pipe which is larger than 50mm must be used in an upflow application, a 50mm elbow must be applied at the flue collar in order to properly transition to the larger diameter flue pipe. This elbow must be added to the elbow count used to determine acceptable vent lengths. Assign an equivalent meter value to this elbow according to the larger size pipe being used. Contact Lennox for more information concerning sizing of vent systems which include multiple pipe sizes.

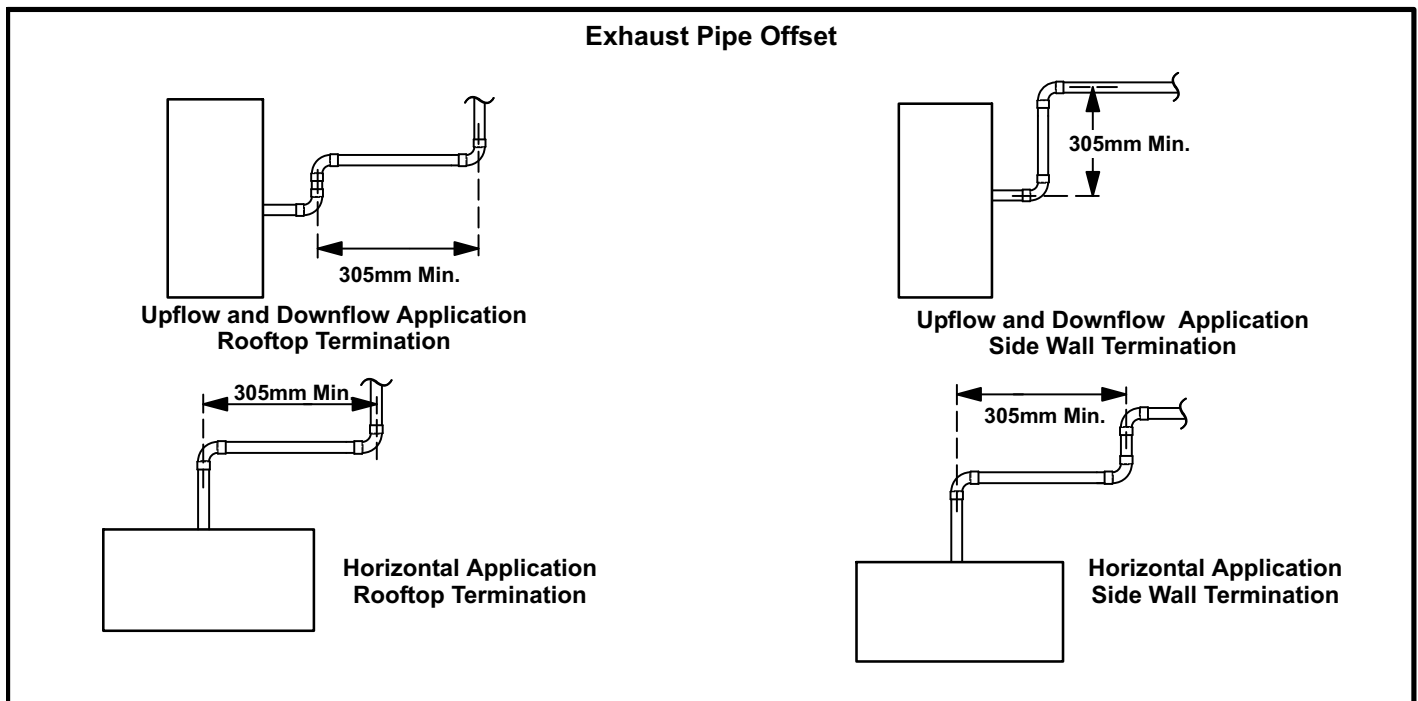

Use the following steps to correctly size vent pipe diameter. **Refer to Vent Pipe Size Determination Worksheet on page 52.**

- 1 - Determine the vent termination and its corresponding equivalent meter value per table 6.
- 2 - Determine the number of 90° elbows required for both indoor and outdoor use. Calculate the corresponding equivalent meters of vent pipe.
- 3 - Determine the number of 45° elbows required for both indoor and outdoor use. Calculate the corresponding equivalent meters of vent pipe.
- 4 - Determine the length of straight pipe required.
- 5 - Add the total equivalent meters calculated in steps 1 through 4 and compare that length to the maximum values given in table 6 for the proposed vent pipe diameter. If the total equivalent length required exceeds the maximum equivalent length listed in the appropriate table, evaluate the next larger size pipe.

**TABLE 5
MINIMUM VENT PIPE LENGTHS**

G61MPVT MODEL	MIN. EQUIV. VENT LENGTH	EXAMPLE
070, 090	4.5m*	1.5m plus 2 elbows of 50mm or 80mm diameter pipe
110***		1.5m plus 2 elbows of 80mm diameter pipe
135***		1.5m plus 2 elbows of 80mm diameter pipe

*Any approved termination may be added to the minimum equivalent length listed.

**G61MPVT-60C-110 and G61MPVT-60D-135 must have 90° street ell (supplied) installed directly into unit flue colla and 50mm to 80mm reducer (supplied) must be installed on the 50mm ell.

NOTE - All 90° elbows used in configuration of vent, must be sweep elbows.

**TABLE 6
MAXIMUM VENT PIPE LENGTHS**

ALTITUDE	G61MPVT MODEL	MAXIMUM EQUIVALENT VENT LENGTH METERS		
		50mm dia.	80mm dia.	100mm dia.
0 - 610m	070	12.2	16.1	44
	090	4.5	12.2	34.5
	110*	n/a	12.2	30
	135*	n/a	7.6	20
611 -1372m	070	7.6	10	27.5
	090	n/a	7.6	21.5
	110*	n/a	7.6	18.7
	135*	n/a	n/a	n/a

n/a -- Not allowed.

*G61MPVT-60C-110 and G61MPVT-60D-135 must have 90° street ell (supplied) installed directly into unit flue colla and 50mm to 80mm reducer (supplied) must be installed on the 50mm ell.

NOTE - All 90° elbows used in configuration of vent, must be sweep elbows.

⚠ IMPORTANT

The G61MPVT unit is not suitable for use at elevations over 610m.

Joint Cementing Procedure

All cementing of joints should be done according to the relevant local authority.

⚠ WARNING

DANGER OF EXPLOSION!

Fumes from PVC glue may ignite during system check. Allow fumes to dissipate for at least 5 minutes before placing unit into operation.

- 1 - Measure and cut vent pipe to desired length.
- 2 - Debur and chamfer end of pipe, removing any ridges or rough edges. If end is not chamfered, edge of pipe may remove cement from fitting socket and result in a leaking joint.
- 3 - Clean and dry surfaces to be joined.
- 4 - Test fit joint and mark depth of fitting on outside of pipe.
- 5 - Uniformly apply liberal coat of PVC primer for PVC or ABS cleaner for ABS to inside socket surface of fitting and male end of pipe to depth of fitting socket.
- 6 - Promptly apply solvent cement to end of pipe and inside socket surface of fitting. Cement should be applied lightly but uniformly to inside of socket. Take care to keep excess cement out of socket. Apply second coat to end of pipe.

NOTE - Time is critical at this stage. Do not allow primer to dry before applying cement.

- 7 - Immediately after applying last coat of cement to pipe, and while both inside socket surface and end of pipe are wet with cement, forcefully insert end of pipe into socket until it bottoms out. Turn pipe 1/4 turn during assembly (but not after pipe is fully inserted) to distribute cement evenly.

NOTE - Assembly should be completed within 20 seconds after last application of cement. Hammer blows should not be used when inserting pipe.

- 8 - After assembly, wipe excess cement from pipe at end of fitting socket. A properly made joint will show a bead around its entire perimeter. Any gaps may indicate a defective assembly due to insufficient solvent.
- 9 - Handle joints carefully until completely set.

Venting Practices

- 1 - Use recommended piping materials for exhaust piping (**Class E / Class 12 / Schedule 40**).
- 2 - Secure all joints so that they are gas-tight using approved cement.

Suspend piping using hangers at a minimum of every 1.52m (5 feet) for Schedule 40 vent pipe. A suitable hanger can be fabricated by using metal or plastic strapping or a large wire tie.

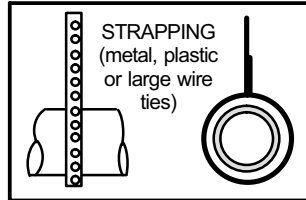

FIGURE 14

- 3 - In areas where piping penetrates joists or interior walls, hole must be large enough to allow clearance on all sides of pipe through center of hole using a hanger.
- 4 - Isolate piping at the point where it exits the outside wall or roof in order to prevent transmission of vibration to the structure.
- 5 - When furnace is installed in a residence where unit is shut down for an extended period of time, such as a vacation home, make provisions for draining condensate collection trap and lines.

Exhaust Piping (Figures 15 and 16)

*NOTE - Two 50mm diameter street ells and two 80mm to 50mm reducers are contained in a bag assembly strapped to the blower deck of 60C-110 and 60D-135 units. The street ells **must be** glued directly into the unit flue collar. See figure 15. The 80mm to 50mm reducers must be glued to the street ells in **upflow or downflow applications**.*

- 1 - Choose the appropriate side for venting in upflow or

downflow positions. Exhaust piping exits from the top of the unit in horizontal air discharge applications. Glue the field-provided exhaust vent pipe (or provided street ell or reducing ell in upflow or downflow applications) to the flue collar. Refer to pipe and fittings specifications and gluing procedures.

⚠ IMPORTANT

Exhaust piping and condensate trap must be installed on the same side of the unit in upflow and downflow applications.

- 2 - All horizontal runs of exhaust pipe must slope back toward unit. A minimum of 6mm (1/4") drop for each 305mm (12 inches) of horizontal run is mandatory for drainage. Horizontal runs of exhaust piping must be supported every 1.5m (5 feet) using hangers.

NOTE - Exhaust piping should be checked carefully to make sure there are no sags or low spots.

- 3 - On the opposite side of the cabinet, glue the provided 50mm vent plug into the unused flue collar.
- 4 - Route piping to outside of structure. Continue with installation following instructions given in piping termination section.

⚠ CAUTION

Do not discharge exhaust into an existing stack or stack that also serves another gas appliance. If vertical discharge through an existing unused stack is required, insert PVC pipe inside the stack until the end is even with the top or outlet end of the metal stack.

⚠ CAUTION

The exhaust vent pipe operates under positive pressure and must be completely sealed to prevent leakage of combustion products into the living space.

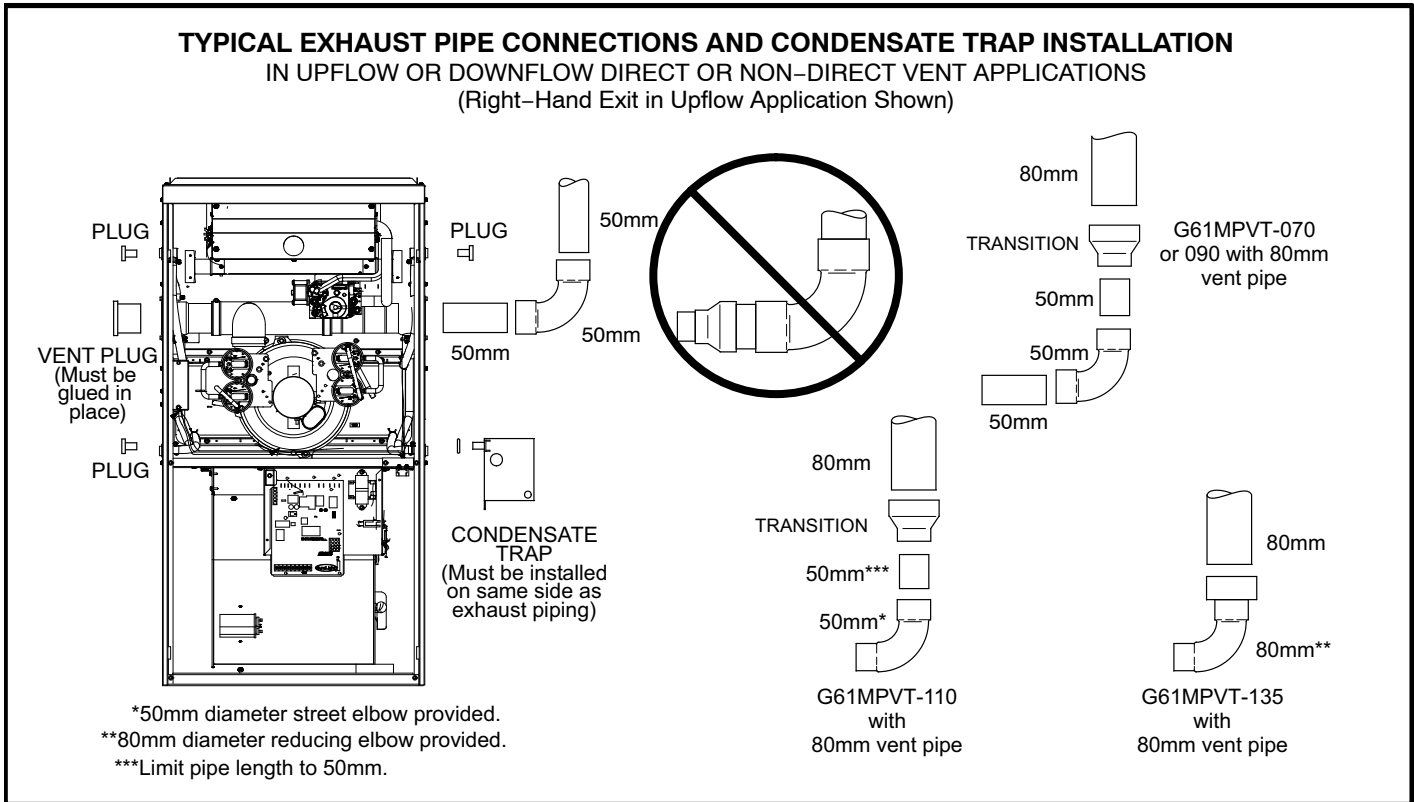

FIGURE 15

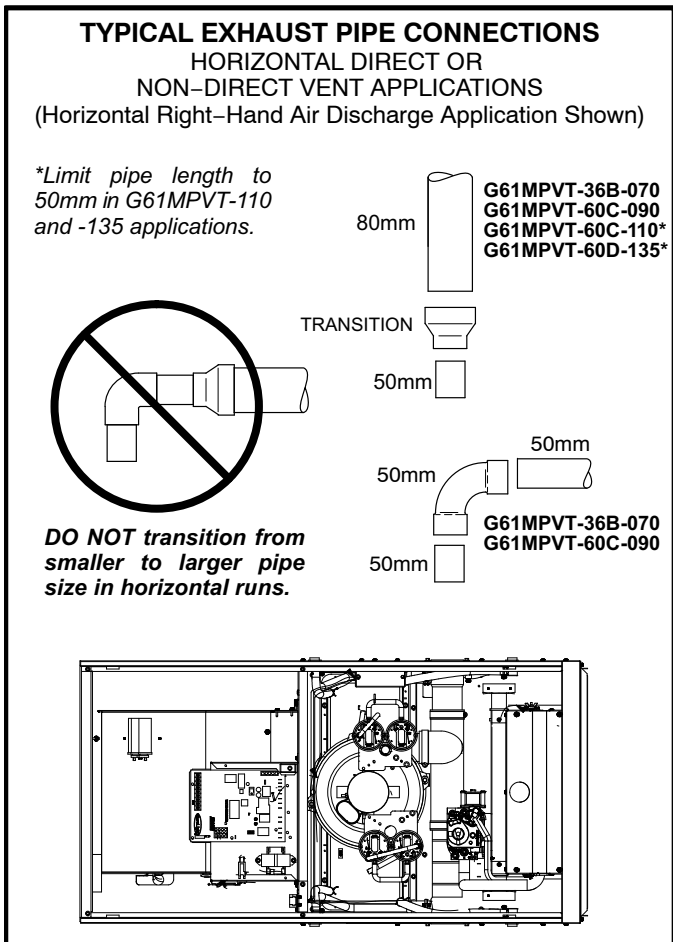

FIGURE 16

Intake Piping

G61MPVT furnaces, with the exception of the G61MPVT-60D-135, can be installed as either a Non-Direct Vent or a Direct Vent gas central furnace. The G61MPVT-60D-135 can only be installed as a Direct Vent (two pipe) gas central furnace. In non-direct vent applications, when intake air will be drawn into the furnace from the surrounding space, the indoor air quality must be considered and guidelines listed in Combustion, Dilution and Ventilation Air section must be followed.

The G61MPVT unit is designed for either left-side or right-side air intake connections in either upflow or downflow applications. In horizontal applications, air intake must be brought in through the top. Intake air piping is independent of exhaust piping.

Follow the next four steps when installing the unit in **direct vent applications**, where combustion air is taken from outdoors and flue gases are discharged outdoors.

- 1 - Cement intake piping in slip connector located on the side of the burner box.
- 2 - Use a sheet metal screw to secure the intake pipe to the connector, if desired. A pilot indentation is provided in the slip connector to assist in locating and starting the fastener.
- 3 - Glue the provided 50mm plug into the unused air intake connector on the opposite side of the cabinet.
- 4 - Route piping to outside of structure. Continue with installation following instructions given in general guide lines for piping terminations and in intake and exhaust piping terminations for direct vent sections. Refer to figure 17 for pipe sizes.

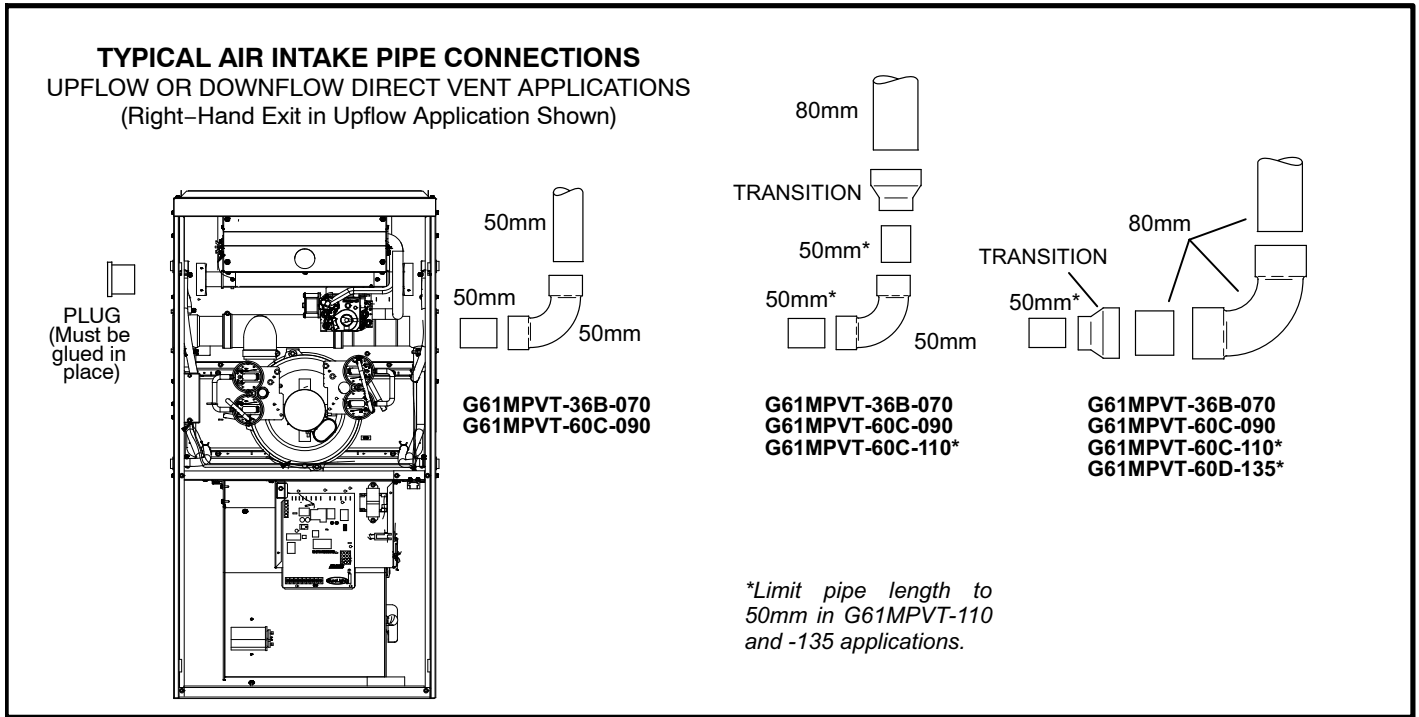

FIGURE 17

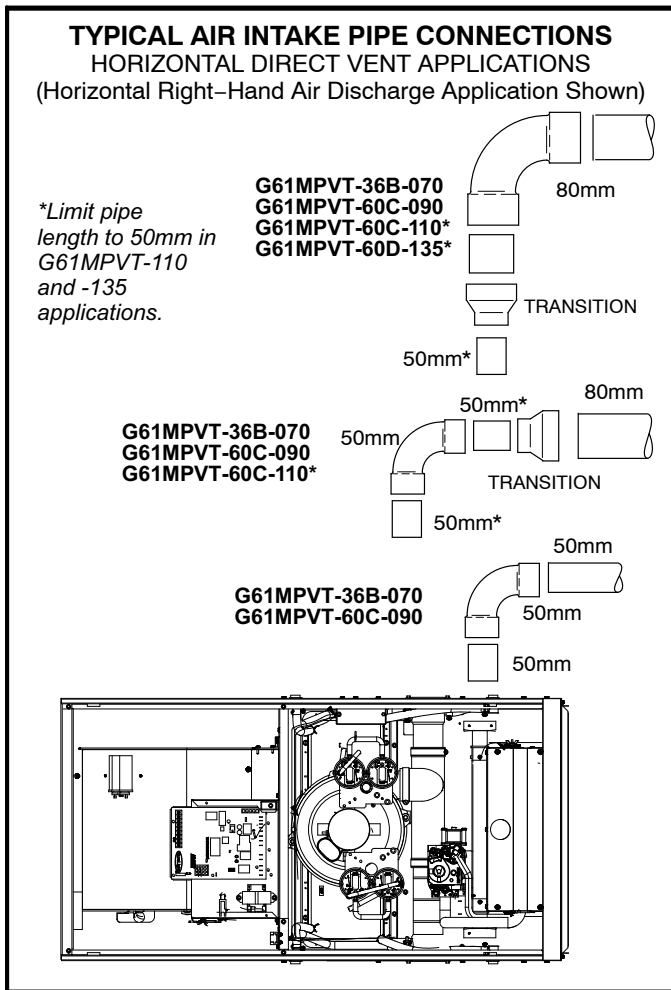

FIGURE 18

Follow the next three steps when installing the unit in **Non-Direct Vent applications** where combustion air is taken from indoors and flue gases are discharged outdoors.

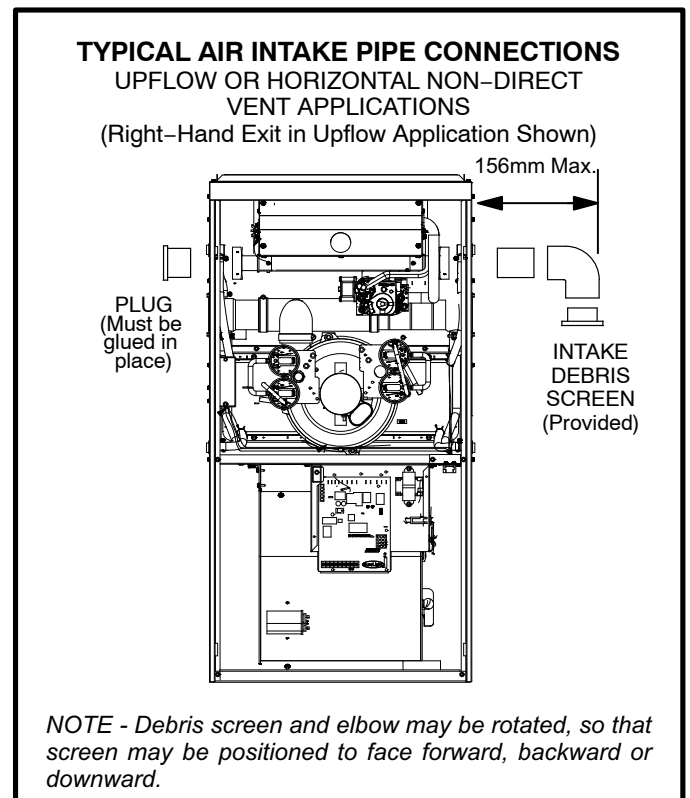
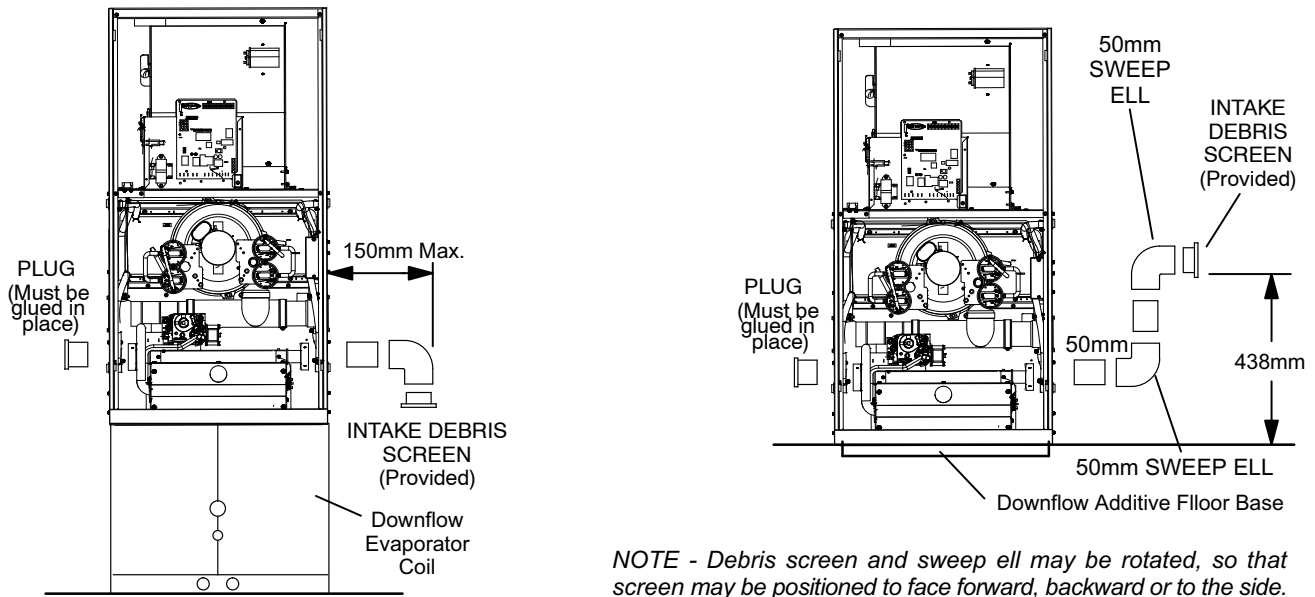

FIGURE 19

TYPICAL AIR INTAKE PIPE CONNECTIONS
DOWNFLOW NON-DIRECT VENT APPLICATIONS
 (Right-Hand Exit in Downflow Applications Shown)



NOTE - Debris screen and sweep ell may be rotated, so that screen may be positioned to face forward, backward or to the side.

FIGURE 20

1 - Use field-provided materials and the factory-provided air intake screen to route the intake piping as shown in figures 19 and 20. Maintain a minimum clearance of 76mm (3 inches) around the air intake opening. The air intake opening (with the protective screen) should always be directed either downward or straight out. Use 50mm pipe and fittings only and make sure that the air intake does not extend more than 156mm (6inches) beyond the G61MPVT cabinet.

The air intake connector must not be located near the floor. To avoid this complication in downflow applications which do not include a downflow evaporator coil, the intake air routing should be modified as shown in figure 20.

- 2 - Use a sheet metal screw to secure the intake pipe to the connector, if desired. A pilot indentation is provided in the slip connector to assist in locating and starting the fastener.
- 3 - Glue the provided 50mm plug into the unused air intake connector on the opposite side of the cabinet.

Testing for Proper Venting and Sufficient Combustion Air
(Non-Direct Vent Applications Only)

⚠ WARNING

CARBON MONOXIDE POISONING HAZARD!

Failure to follow the steps outlined below for each appliance connected to the venting system being placed into operation could result in carbon monoxide poisoning or death.

The following steps shall be followed for each appliance connected to the venting system being placed into operation, while all other appliances connected to the venting system are not in operation.

After the G61MPVT gas furnace has been started, the following test should be conducted to ensure proper venting and sufficient combustion air has been provided to the G61MPVT, as well as to other gas-fired appliances which are separately vented. The test should be conducted while all appliances (both in operation and those not in operation) are connected to the venting system being tested.

If the venting system has been installed improperly, or if provisions have not been made for sufficient amounts of combustion air, corrections must be made as outlined in the previous section.

- 1 - Seal any unused openings in the venting system.
- 2 - Visually inspect the venting system for proper size and horizontal pitch. Determine there is no blockage or restriction, leakage, corrosion, or other deficiencies which could cause an unsafe condition.
- 3 - To the extent that it is practical, close all building doors and windows and all doors between the space in which the appliances connected to the venting system are located and other spaces of the building.
- 4 - Close fireplace dampers.
- 5 - Turn on clothes dryers and any appliances not connected to the venting system. Turn on any exhaust fans, such as range hoods and bathroom exhausts, so they will operate at maximum speed. Do not operate a summer exhaust fan.
- 6 - Follow the lighting instruction to place the appliance being inspected into operation. Adjust thermostat so appliance will operate continuously.
- 7 - Test for spillage of flue gases at the draft hood relief opening after 5 minutes of main burner operation. Use the flame of match or candle, or smoke from a cigarette, cigar.
- 8 - If improper venting is observed during any of the above tests, the venting system must be corrected or sufficient combustion/make-up air must be provided.
- 9 - After determining that each appliance remaining connected to the common venting system properly vents when tested as indicated in step 3, return doors, windows, exhaust fans, fireplace dampers and any other gas-burning appliance to their previous condition of use.

General Guidelines for Vent Terminations for Non-Direct Vent Installations.

In Non-Direct Vent applications, combustion air is taken

from indoors and the flue gases are discharged to the outdoors. The G61MPVT is then classified as a non-direct vent gas furnace. In Non-Direct Vent applications, the vent termination is limited by local building codes.

Position termination end according to location given in figure 21. In addition, position termination end so it is free from any obstructions and above the level of snow accumulation (where applicable). The termination should be at least 305mm (12 inches) from any opening through which flue products could enter the building.

At vent termination, care must be taken to maintain protective coatings over building materials (prolonged exposure to exhaust condensate can destroy protective coatings). It is recommended that the exhaust outlet not be located within 1.8m (6 feet) of a condensing unit because the condensate can damage the painted coating.

NOTE - If winter design temperature is below 0°C (32°F), exhaust piping should be insulated with 13mm (1/2 inch), Armaflex or equivalent when run through unheated space. Do not leave any surface area of exhaust pipe open to outside air; exterior exhaust pipe should be insulated with 13mm (1/2 inch) Armaflex or equivalent. In extreme cold climate areas, 19mm (3/4 inch) Armaflex or equivalent may be necessary. Insulation on outside runs of exhaust pipe must be painted or wrapped to protect insulation from deterioration. Exhaust pipe insulation may not be necessary in some specific applications.

NOTE - During extremely cold temperatures, below approximately -6.7°C (20°F), units with long runs of vent pipe through unconditioned space, even when insulated, may form ice in the exhaust termination that prevents the unit from operating properly. Longer run times of at least 5 minutes will alleviate most icing problems. Also, a heating cable may be installed on exhaust piping and termination to prevent freeze-ups. Heating cable installation kit is available from Lennox.

VENT TERMINATION CLEARANCES (AS 5601)

- ▼ - G61MPVT VENT TERMINATION
- Ⓐ - AIR INLET OF OTHER APPLIANCE

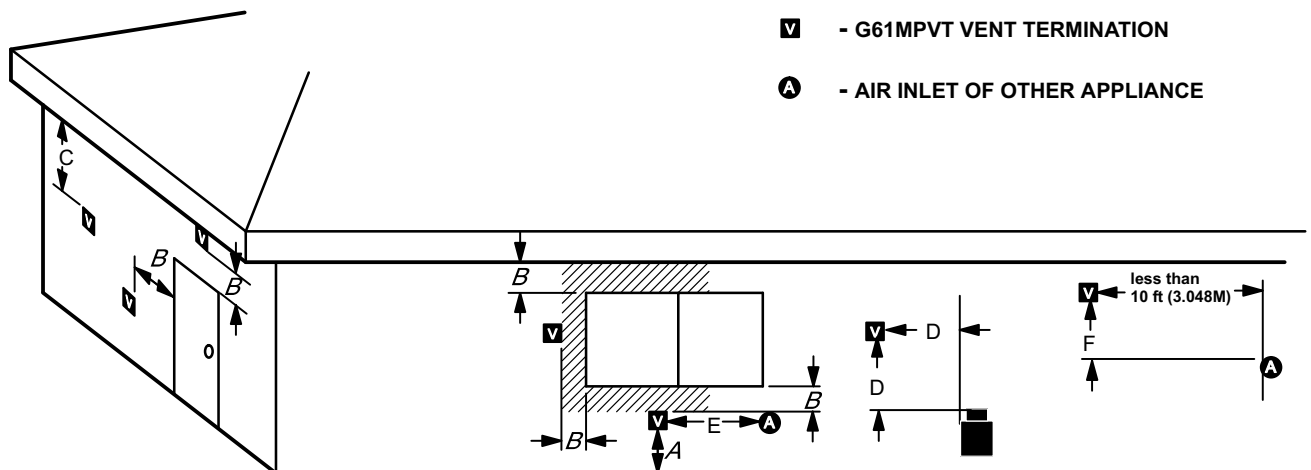

- A - Clearance above ground level - 305mm.
- B - Clearance horizontally to window or door that may be opened - 305mm minimum for appliances up to 150MJ/h; Clearance vertically below a window that may be opened - 1000mm minimum for appliances up to 150MJ/h.
- C - Clearance below eaves, balconies and other projections - 305mm.
- D - Clearance to electric meters, gas meters, regulators and relief equipment - 1000mm minimum.
- E - Clearance to non-mechanical air supply inlet or outlet - 300mm minimum horizontal and 1000mm minimum vertically for appliances up to 150MJ/h;
- F - Clearance to mechanical air supply inlet including a spa blower -- 1000mm minimum.
- G - Do not point terminations into recessed areas such as window wells, stairwells or alcoves.
- H - Do not position terminations directly above a walkway.

FIGURE 21

Details of Intake and Exhaust Piping Terminations for Direct Vent Installations

NOTE - In Direct Vent installations, combustion air is taken from outdoors and flue gases are discharged to outdoors. Intake and exhaust pipes may be routed either horizontally through an outside wall or vertically through the roof. In attic or closet installations, vertical termination through the roof is preferred. Figures 22 through 25 show typical terminations.

- 1 - Exhaust and intake exits must be in same pressure zone. Do not exit one through the roof and one on the side. Also, do not exit the intake on one side and the exhaust on another side of the house or structure.
- 2 - Intake and exhaust pipes should be placed as close together as possible at termination end (refer to illustrations). Maximum separation is 76mm (3 inches) on roof terminations and 152mm (6 inches) on side wall terminations.

- 3 - If necessary, install a field-provided transition to adapt larger vent pipe size to termination pipe size.
- 4 - On roof terminations, the intake piping should terminate straight down using two 90° elbows (See figure 22).
- 5 - Exhaust piping must terminate straight out or up as shown. In rooftop applications, a reducer may be required on the exhaust piping at the point where it exits the structure to improve the velocity of exhaust away from the intake piping. See table 7.

NOTE - Care must be taken to avoid recirculation of exhaust back into intake pipe.

- 6 - On field supplied terminations for side wall exits, exhaust piping should extend a maximum of 305mm (12 inches) beyond the outside wall unless supported. Intake piping should be as short as possible.

7 - On field supplied terminations, a minimum separation distance between the end of the exhaust pipe and the end of the intake pipe is 203mm (8 inches).

**TABLE 7
EXHAUST PIPE TERMINATION SIZE REDUCTION**

G61MPVT MODEL	Exhaust Pipe Size	Termination Pipe Size
070	50 or 80mm	40mm
090	50 or 80mm	50mm
110	80mm	50mm*
135	80mm	50mm*

*Approved 3" concentric termination kit terminates with 2-5/8" ID pipe.

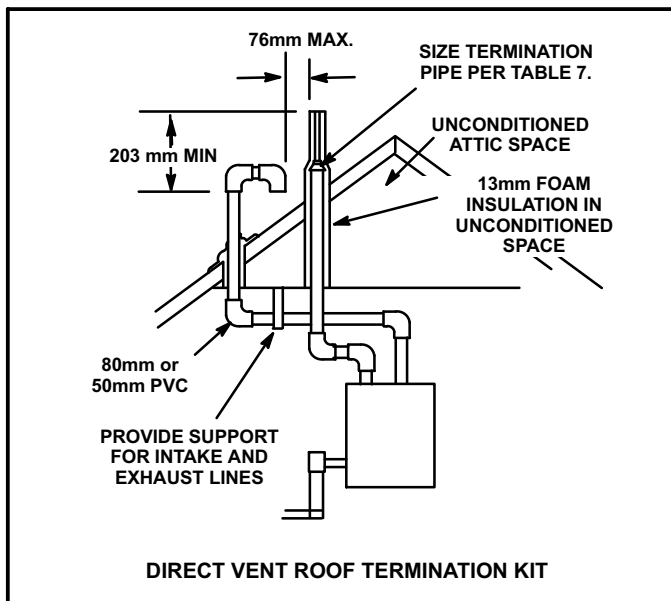

FIGURE 22

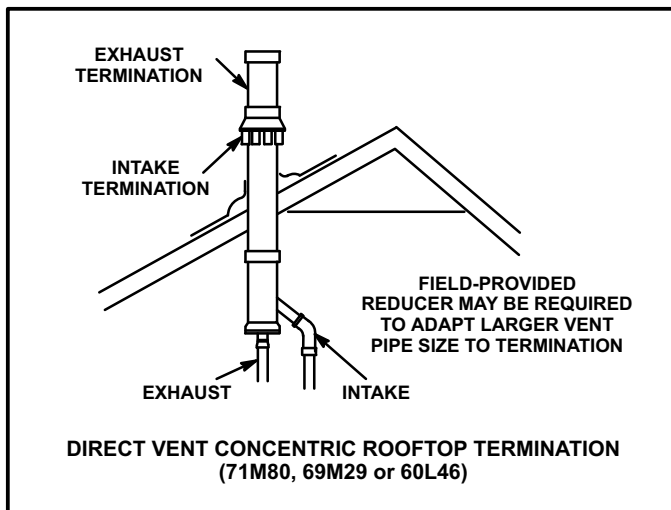

FIGURE 23

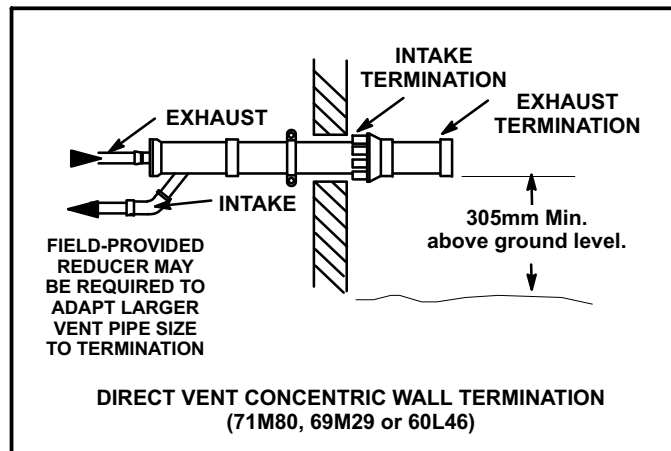

FIGURE 24

Details of Exhaust Piping Terminations for Non-Direct Vent Applications

Exhaust pipes may be routed either horizontally through an outside wall or vertically through the roof. In attic or closet installations, vertical termination through the roof is preferred. Figure 25 shows a typical terminations.

- 1 - Exhaust piping must terminate straight out or up as shown. The termination pipe must be sized as listed in table 7. The specified pipe size ensures proper velocity required to move the exhaust gases away from the building.
- 2 - On field supplied terminations for side wall exits, exhaust piping should extend a maximum of 305mm (12 inches) beyond the outside wall, unless support is provided in the horizontal section.

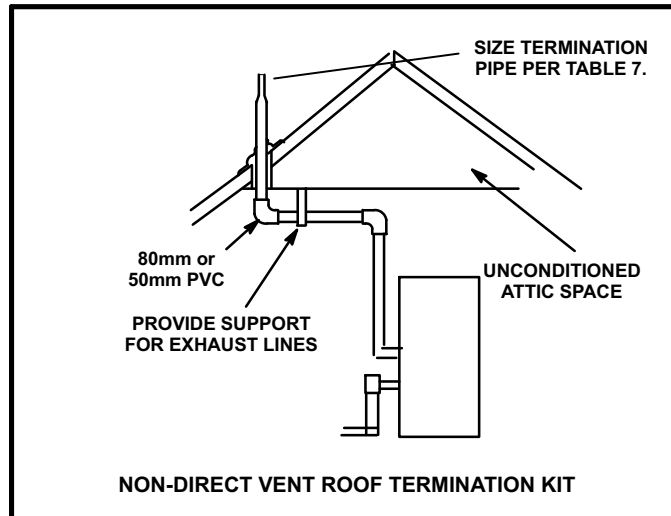

FIGURE 25

Condensate Piping

This unit is designed for either right- or left-side exit of condensate piping in either upflow or downflow applications; however, it must be installed on the same side of the unit as the exhaust piping. In horizontal applications, the condensate trap should extend below the unit. A 140mm (5-1/2-inch) service clearance is required for the condensate trap. Refer to figure 26 for condensate trap locations.

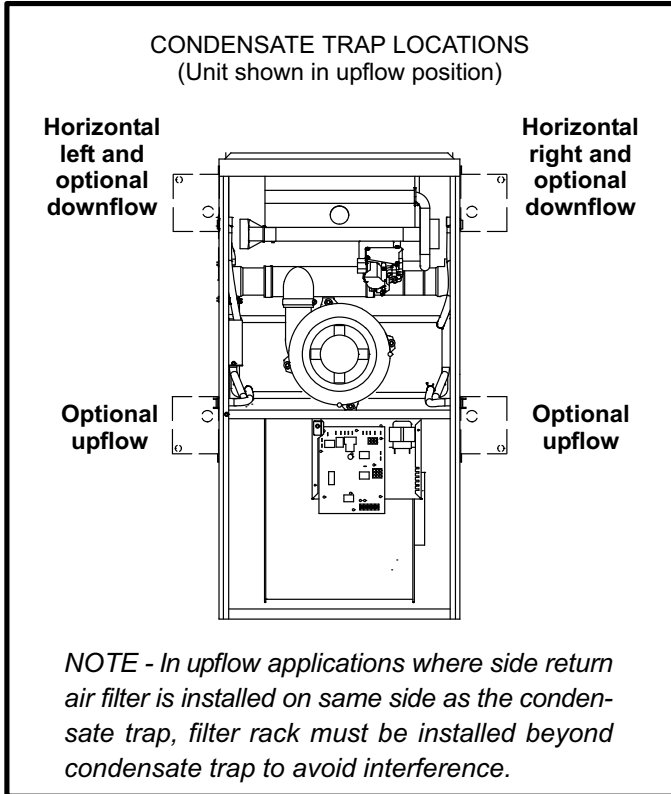

FIGURE 26

- 1 - Determine which side condensate piping will exit the unit. Remove plugs from the condensate collar at the appropriate location on the side of the unit.

NOTE - The condensate trap is factory-shipped with two rubber O-rings and two rubber clean-out caps installed. Check to make sure that these items are in place before installing the trap assembly.

- 2 - Install condensate trap onto the condensate collar. Use provided HI/LO screws to secure two upper flanges of the trap to the collar. Use provided sheet metal screw to secure bottom trap flange to side of unit. See figure 27.

NOTE - In upflow and downflow applications, condensate trap must be installed on the same side as exhaust piping.

- 3 - Glue the field-provided coupling or pipe to the trap. Install a tee and vent pipe near the trap.

NOTE - The condensate trap drain stubs (both sides) have an outer diameter which will accept a standard 19mm (3/4") PVC coupling. The inner diameter of each stub will accept standard 13mm (1/2") diameter PVC pipe.

NOTE - Vinyl tubing may be used for condensate drain. Tubing must be 32mmOD X 25mm ID (1-1/4" OD X 1" ID) and should be attached to the drain stubs on the trap using a hose clamp.

- 4 - Glue the field-provided drain line to the tee. Route the drain line to an open drain. As an alternate, clear vinyl tubing may be used to drain condensate away from the trap. Secure the vinyl tubing to the drain stubs on the trap using a hose clamp. Do not overtighten the hose clamp.

Condensate line must be sloped downward away from condensate trap to drain. If drain level is above condensate trap, condensate pump must be used.

⚠ CAUTION

Do not use copper tubing or existing copper condensate lines for drain line.

- 5 - If unit will be started immediately upon completion of installation, prime trap per procedure outlined in Unit Start-Up section.
- 6 - Glue the provided cap onto the unused condensate drain line stub.

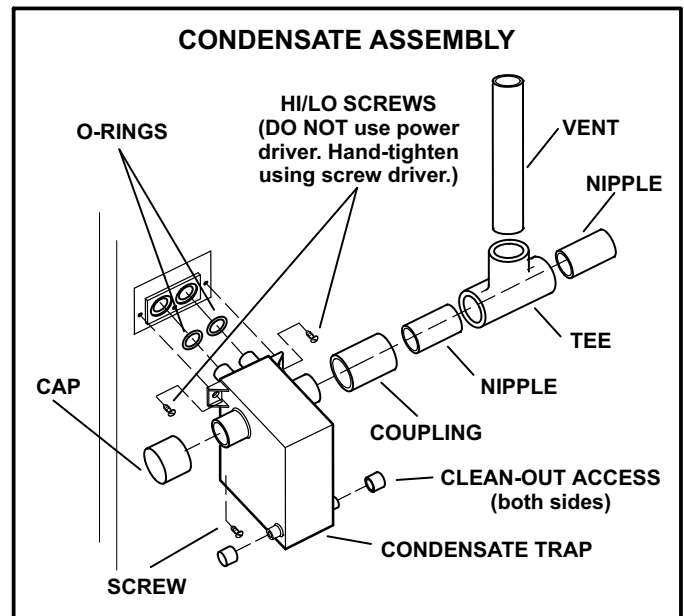

FIGURE 27

Gas Piping

⚠ CAUTION

DO NOT over-tighten when attaching pipe or fittings to gas valve. Damage may occur.

- 1 - Gas piping may be routed into the unit through either the left- or right-hand side. Supply piping enters into the gas valve from the side of the valve as shown in figures 29 and 30.
- 2 - When connecting gas supply, factors such as length of run, number of fittings and furnace rating must be considered to avoid excessive pressure drop. Table 8 lists recommended pipe sizes for typical applications.
NOTE - Use two wrenches when connecting gas piping to avoid transferring torque to the manifold.
- 3 - Gas piping must not run in or through air ducts, clothes chutes, chimneys or gas vents, dumb waiters or elevator shafts. Center gas line through piping hole. Gas line should not touch side of unit. See figures 29 and 30.
- 4 - Piping should be sloped 1/4 inch per 15 feet (6mm per 5.6m) upward toward the gas meter from the furnace. The piping must be supported at proper intervals, every 2.44 to 3.05m (8 to 10 feet), using suitable hangers or straps. Install a drip leg in vertical pipe runs to serve as a trap for sediment or condensate.
- 5 - A 1/8" N.P.T. plugged tap or pressure post is located on the gas valve to facilitate test gauge connection. See figure 34.
- 6 - In some localities, codes may require installation of a manual main shut-off valve and union (furnished by installer) external to the unit. Union must be of the ground joint type.

⚠ IMPORTANT

Compounds used on threaded joints of gas piping must be resistant to the actions of liquified petroleum gases.

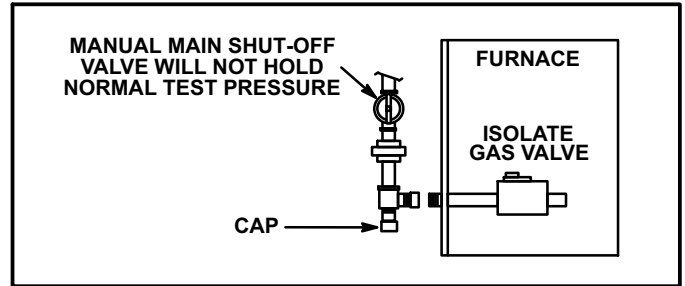

FIGURE 28

Leak Check

After gas piping is completed, carefully check all piping connections (factory- and field-installed) for gas leaks. Use a leak detecting solution or other preferred means.

The furnace must be isolated from the gas supply system by closing its individual manual shut-off valve during any pressure testing of the gas supply system at pressures less than or equal to 1/2 psig (3.48 kPa, 14 inches w.c.).

⚠ IMPORTANT

When testing gas lines using pressures in excess of 1/2 psig (3.48 kPa), gas valve must be disconnected and isolated. See figure 28. Gas valves can be damaged if subjected to pressures greater than 1/2 psig (3.48 kPa).

⚠ WARNING

FIRE OR EXPLOSION HAZARD

Failure to follow the safety warnings exactly could result in serious injury, death, or property damage. Never use an open flame to test for gas leaks. Check all connections using a commercially available soap solution made specifically for leak detection. Some soaps used for leak detection are corrosive to certain metals. Carefully rinse piping thoroughly after leak test has been completed.

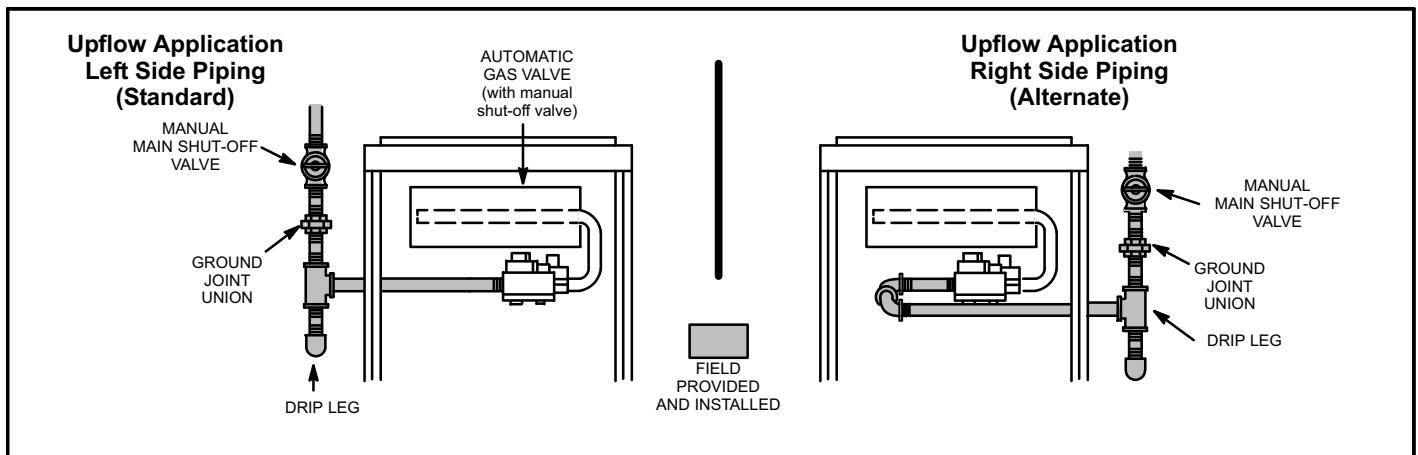

FIGURE 29

**Horizontal Applications
Possible Gas Piping Configurations**

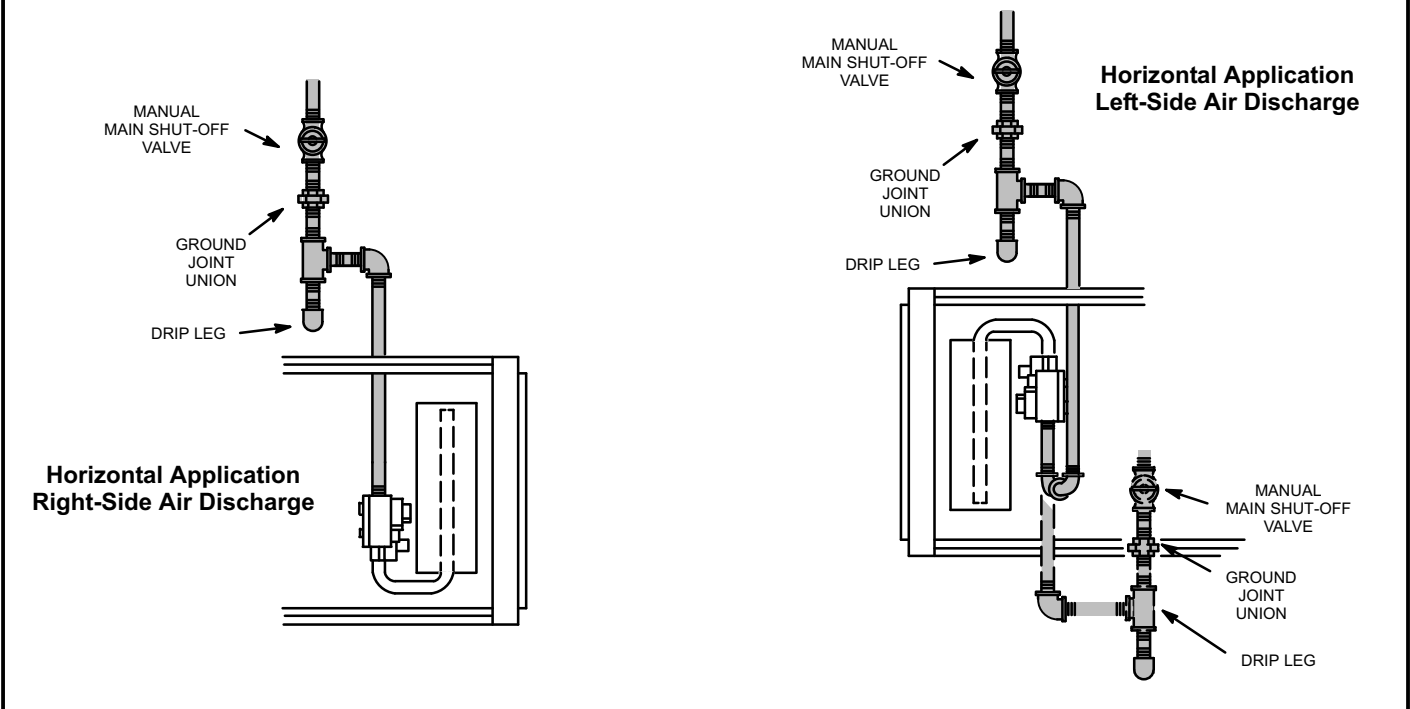

FIGURE 30

**TABLE 8
GAS PIPE CAPACITY - FT³/HR (kL/HR)**

Nominal Iron Pipe Size -Inches(mm)	Internal Diameter -Inches(mm)	Length of Pipe-Feet(m)									
		10 (3.048)	20 (6.096)	30 (9.144)	40 (12.192)	50 (15.240)	60 (18.288)	70 (21.336)	80 (24.384)	90 (27.432)	100 (30.480)
1/4 (6.35)	.364 (9.246)	43 (1.13)	29 (.82)	24 (.68)	20 (.57)	18 (.51)	16 (.45)	15 (.42)	14 (.40)	13 (.37)	12 (.34)
3/8 (9.53)	.493 (12.522)	95 (2.69)	65 (1.84)	52 (1.47)	45 (1.27)	40 (1.13)	36 (1.02)	33 (.73)	31 (.88)	29 (.82)	27 (.76)
1/2 (12.7)	.622 (17.799)	175 (4.96)	120 (3.40)	97 (2.75)	82 (2.32)	73 (2.07)	66 (1.87)	61 (1.73)	57 (1.61)	53 (1.50)	50 (1.42)
3/4 (19.05)	.824 (20.930)	360 (10.19)	250 (7.08)	200 (5.66)	170 (4.81)	151 (4.28)	138 (3.91)	125 (3.54)	118 (3.34)	110 (3.11)	103 (2.92)
1 (25.4)	1.049 (26.645)	680 (19.25)	465 (13.17)	375 (10.62)	320 (9.06)	285 (8.07)	260 (7.36)	240 (6.80)	220 (6.23)	205 (5.80)	195 (5.52)
1-1/4 (31.75)	1.380 (35.052)	1400 (39.64)	950 (26.90)	770 (21.80)	660 (18.69)	580 (16.42)	530 (15.01)	490 (13.87)	460 (13.03)	430 (12.18)	400 (11.33)
1-1/2 (38.1)	1.610 (40.894)	2100 (59.46)	1400 (41.34)	1180 (33.41)	990 (28.03)	900 (25.48)	810 (22.94)	750 (21.24)	690 (19.54)	650 (18.41)	620 (17.56)
2 (50.8)	2.067 (52.502)	3950 (111.85)	2750 (77.87)	2200 (62.30)	1900 (53.80)	1680 (47.57)	1520 (43.04)	1400 (39.64)	1300 (36.81)	1220 (34.55)	1150 (32.56)
2-1/2 (63.5)	2.469 (67.713)	6300 (178.39)	4350 (123.17)	3520 (99.67)	3000 (84.95)	2650 (75.04)	2400 (67.96)	2250 (63.71)	2050 (58.05)	1950 (55.22)	1850 (52.38)
3 (76.2)	3.068 (77.927)	11000 (311.48)	7700 (218.03)	6250 (176.98)	5300 (150.07)	4750 (134.50)	4300 (121.76)	3900 (110.43)	3700 (104.77)	3450 (97.69)	3250 (92.03)
4 (101.6)	4.026 (102.260)	23000 (651.27)	15800 (447.39)	12800 (362.44)	10900 (308.64)	9700 (274.67)	8800 (249.18)	8100 (229.36)	7500 (212.37)	7200 (203.88)	6700 (189.72)

NOTE - Capacity given in cubic feet of gas per hour (kilo liters of gas per hour) and based on 0.60 specific gravity gas.

Electrical

ELECTROSTATIC DISCHARGE (ESD) Precautions and Procedures

⚠ CAUTION

Electrostatic discharge can affect electronic components. Take precautions during furnace installation and service to protect the furnace's electronic controls. Precautions will help to avoid control exposure to electrostatic discharge by putting the furnace, the control and the technician at the same electrostatic potential. Neutralize electrostatic charge by touching hand and all tools on an unpainted unit surface, such as the gas valve or blower deck, before performing any service procedure.

A power wiring harness is shipped with each G61MPVT furnace. An IEC receptacle is provided on the right side of the unit. Plug the harness into the IEC receptacle and into a properly sized wall plug.

Refer to figure 31 and table 9 for field wiring and figure 32 for schematic wiring diagram and troubleshooting.

- 1 - Ensure that power connection point is located with 2m of furnace.
- 2 - Holes are on both sides of the furnace cabinet to facilitate thermostat wiring.
- 3 - Before connecting the thermostat wiring, check to make sure the wires will be long enough for servicing at a later date. Remove the blower access panel to check the length of the wire.
- 4 - Complete the wiring connections to the equipment. Use the provided unit wiring diagram and the field wiring diagram shown in figure 31 and table 9. Use 18-gauge wire or larger that is suitable for Class II rating for thermostat connections.

- 5 - Electrically ground the unit according to local codes.
NOTE - The G61MPVT furnace contains electronic components that are polarity sensitive. Make sure that the furnace is wired correctly and is properly grounded.
- 6 - One line voltage "EAC" spade terminal is provided on the furnace control board. Any electronic air cleaner rated up to one amp can be connected to this terminal with the neutral leg of the circuit being connected to one of the provided neutral terminals. See figure 33 for control board configuration. This terminal is energized when the indoor blower is operating.
- 7 - One line voltage "HUM" spade terminal is provided on the furnace control board. Any humidifier rated up to one amp can be connected to this terminal with the neutral leg of the circuit being connected to one of the provided neutral terminals. See figure 33 for control board configuration. This terminal is energized in the heating mode when the combustion air inducer is operating.
- 8 - Install the room thermostat according to the instructions provided with the thermostat. See table 9 for thermostat connections. If the furnace is being matched with a heat pump, refer to the instruction packaged with the dual fuel thermostat.

Indoor Blower Speeds

- 1 - When the thermostat is set to "FAN ON," the indoor blower will run continuously at approximately 38% of the second-stage cooling speed when there is no cooling or heating demand.
- 2 - When the G61MPVT is running in the heating mode, the indoor blower will run on the heating speed designated by the positions of DIP switches 7 and 8.
- 3 - When there is a cooling demand, the indoor blower will run on the cooling speed designated by the positions of DIP switches 3 and 4.

TYPICAL G61MPVT FIELD WIRING DIAGRAM

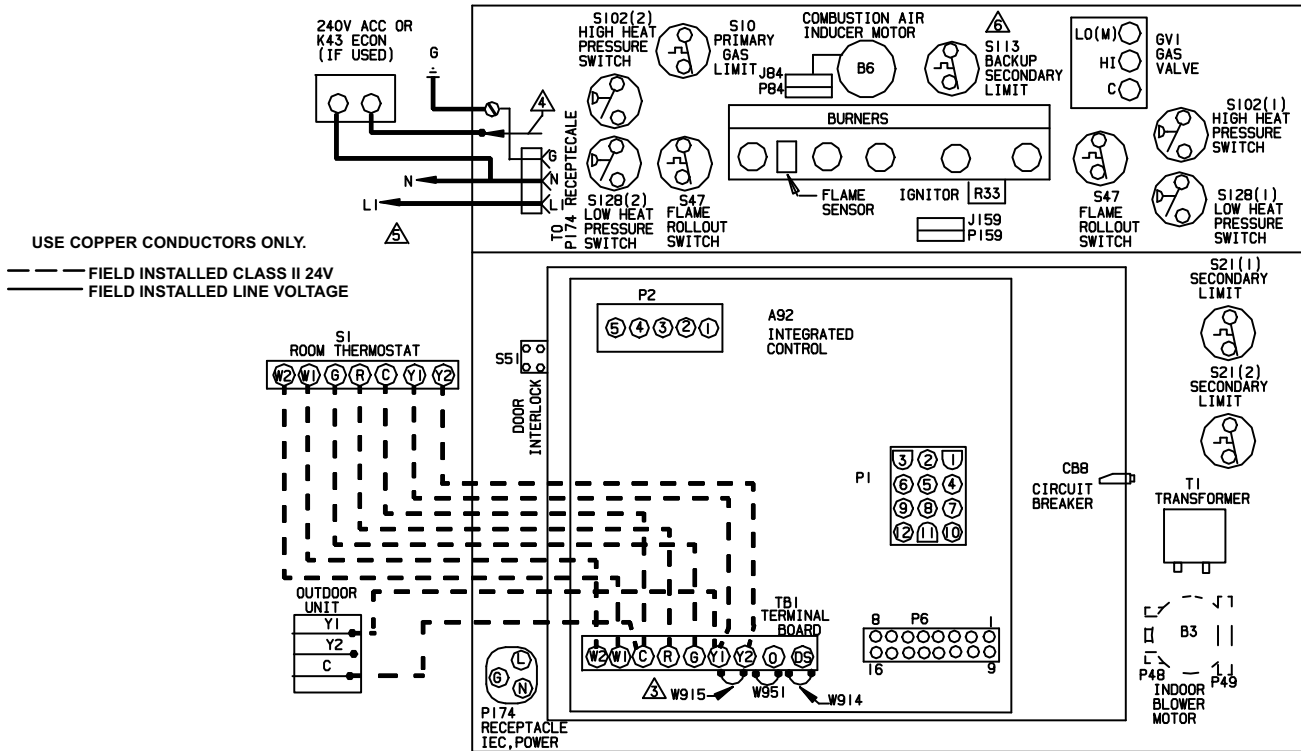

FIGURE 31

TABLE 9
Field Wiring Applications

Thermostat	Jumper Settings (See figure 33)				Wiring Connections
	Heat Staging Jumper	W915 Two-Stage Cooling	W914 Dehumidification	W951 Heat Pumps	
1Heat / 1 Cool <i>NOTE - Use heat staging jumper to set second-stage heat ON delay. No delay (None), 10 minutes, or 15 minutes.</i>	15 Minutes	Intact	Intact	Intact	
2 Heat / 1 Cool <i>NOTE - Use heat staging jumper to set second-stage heat ON delay. No delay (None), 10 minutes, or 15 minutes.</i>	10 Minutes	Intact	Intact	Intact	

TYPICAL G61MPVT WIRING DIAGRAM

BLOWER SPEED CHART			
UNIT	HEAT	COOL	ADJUST
36B-070	2	4	NDRH
60C-090	2	4	NDRH
60C-110	2	4	NDRH
60D-135	2	4	NDRH

NOTE: SEE INSTALLATION INSTRUCTIONS FOR PROCEDURE TO SET CORRECT BLOWER SPEED FOR SPECIFIC COOLING TONNAGE BEING APPLIED, AND HEATING TEMPERATURE RISE DESIRED.

JACKPLUG CHART	
J.P6	JACK/PLUG-OUTPUT
J.P4B	JACK/PLUG-MOTOR/VARIABLE SPEED
J.P4S	JACK/PLUG-MOTOR/VARIABLE SPEED
J.P1	JACK/PLUG-BURNER CONTROL
J.F84	JACK/PLUG-COMB. AIR INDUCER
J.P135	JACK/PLUG-SECONDARY LIMIT
J.P2	JACK/PLUG-INDUCER/IGNITOR
J.P159	JACK/PLUG-IGNITOR

THERMOSTAT HEAT ANTICIPATION SETTING
 .65 AMP HONEYWELL VALVE

- ⚠ IS TO R, CUT W914 JUMPER A92 BURNER CONTROL BOARD WHEN A20 HUMIDITY CONTROL IS USED
- ⚠ R TO D, JUMPER W951 ON A92 BURNER CONTROL BOARD IS USED FOR APPLICATIONS WITH CONDENSING UNITS, DO NOT CUT
- ⚠ LEAVE W915 CLIPPABLE JUMPER CONNECTED FOR ONE STAGE COOL THERMOSTAT, CUT JUMPER W915 AND SEPARATE LEADS FOR TWO STAGE COOL THERMOSTAT.
- ⚠ FIELD SUPPLIED ACC WIRE
- ⚠ USE COPPER CONDUCTORS ONLY
- ⚠ S113 IS USED ON 090,110, AND 135 UNITS ONLY

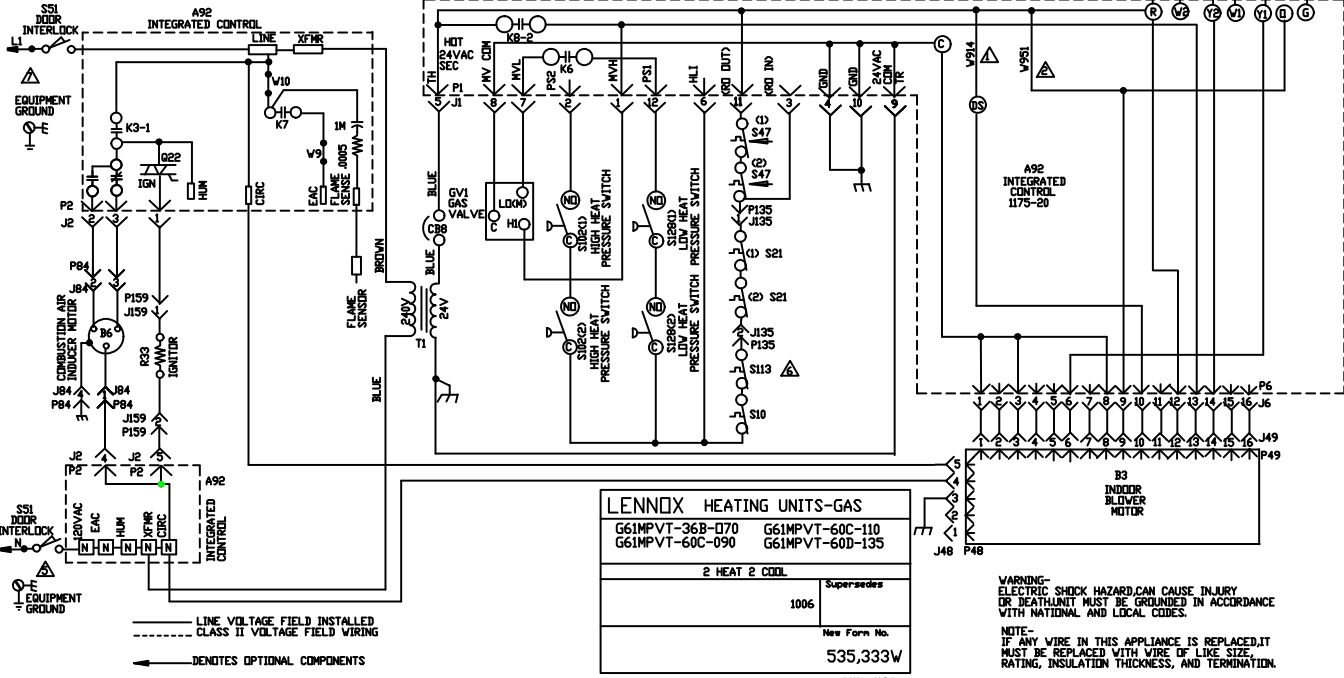
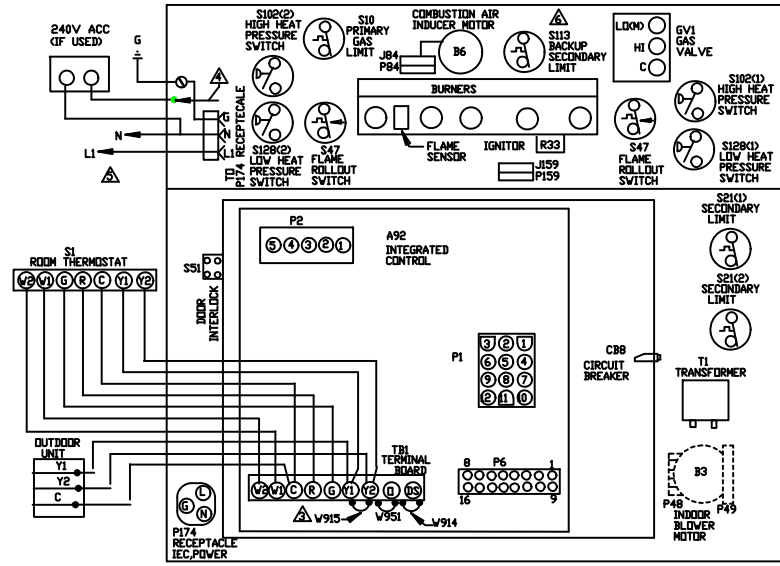

LENNOX HEATING UNITS-GAS	
G61MPVT-36B-070	G61MPVT-60C-110
G61MPVT-60C-090	G61MPVT-60D-135
2 HEAT 2 COOL	
1006	
New Form No.	
535,333W	

WARNING-
 ELECTRIC SHOCK HAZARD CAN CAUSE INJURY OR DEATH. UNIT MUST BE GROUNDED IN ACCORDANCE WITH NATIONAL AND LOCAL CODES.
 NOTE-
 IF ANY WIRE IN THIS APPLIANCE IS REPLACED, IT MUST BE REPLACED WITH WIRE OF LIKE SIZE, RATING, INSULATION THICKNESS, AND TERMINATION.

FIGURE 32

Integrated Control Board

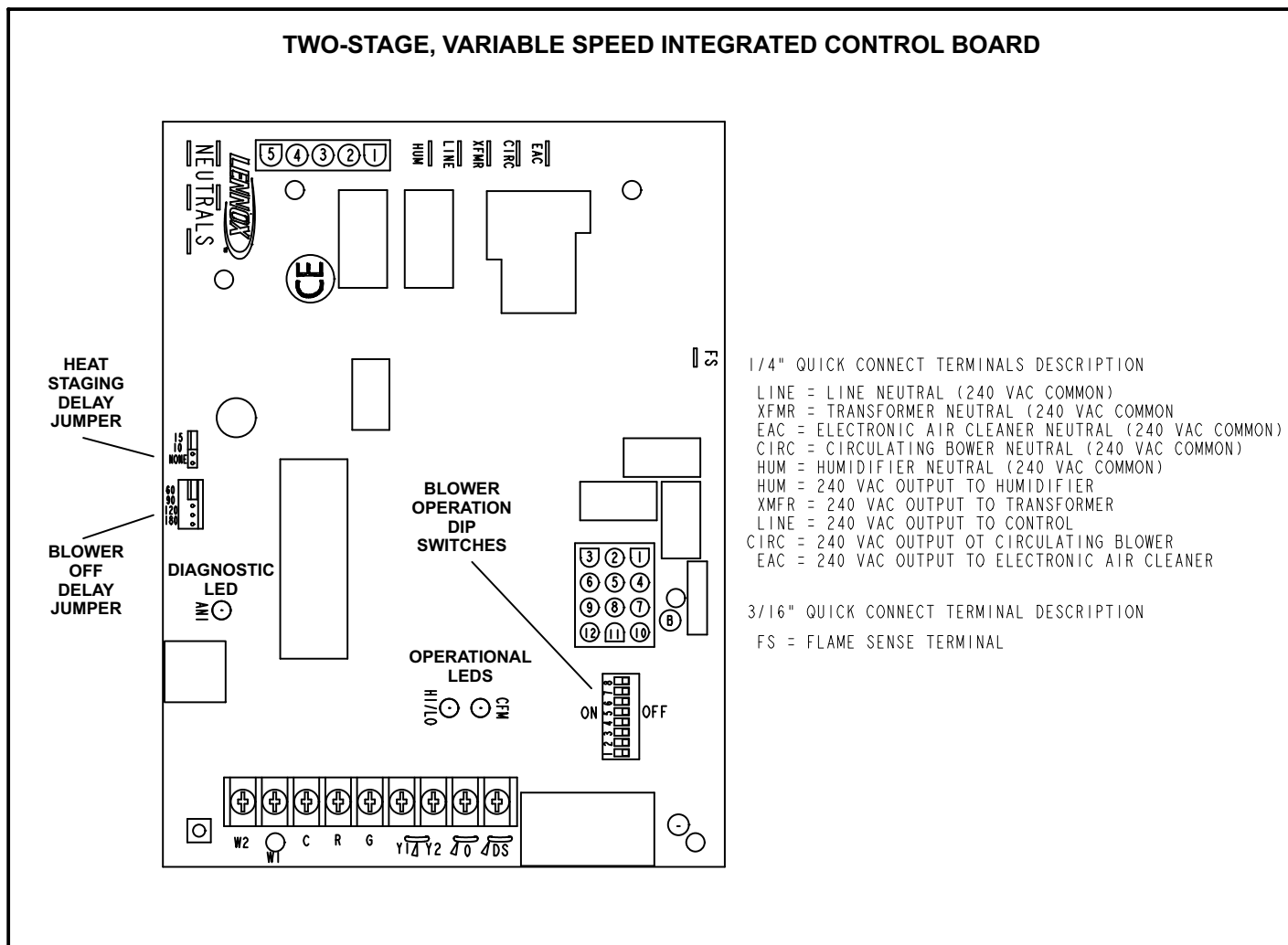

FIGURE 33

G61MPVT units are equipped with a two-stage, variable speed integrated control. This control manages ignition timing, heating mode fan off delays and indoor blower speeds based on selections made using the control dip switches and jumpers. The control includes an internal watchguard feature which automatically resets the ignition control when it has been locked out. After one hour of continuous thermostat demand for heat, the watchguard will break and remake thermostat demand to the furnace and automatically reset the control to relight the furnace.

Heat Staging Jumper

The heat staging jumper is factory-positioned in the NONE position for use with a two-stage thermostat. If a single-stage thermostat is to be used, the jumper must be repositioned.

When the G61MPVT unit is used with single-stage thermostat – The heat staging jumper is used to determine the second stage on delay. The jumper may be positioned to

provide either a 10-minute or a 15-minute delay before second-stage heat is initiated.

Blower-Off Delay Jumper -- The heating mode blower-on delay of 45 seconds is not adjustable. The heating mode blower-off delay (time that the blower operates after the heating demand has been satisfied) can be adjusted by moving blower-off delay jumper on the integrated control board. The unit is shipped from the factory with a blower-off delay of 90 seconds. The blower off delay affects comfort and is adjustable to satisfy individual applications. Adjust the blower off delay to achieve a supply air temperature between 32° and 43°C (90° and 110°F) at the exact moment that the blower is de-energized. Longer off delay settings provide lower supply air temperatures; shorter settings provide higher supply air temperatures. Settings of 60, 90, 120 and 180 seconds are available.

On-Board Jumper W914

On-board jumper W914, which connects terminals DS and R on the integrated control board, must be cut when the furnace is installed with a thermostat which features humidity control.

On-Board Jumper W951

On-board jumper W951, which connects terminals R and O on the integrated control board, must be cut when the furnace is installed in applications which include a heat pump unit and a thermostat which features dual fuel use. If the jumper is left intact, terminal "O" will remain energized eliminating the HEAT MODE in the heat pump.

On-Board Jumper W915

On-board jumper W915, which connects terminals Y1 and Y2 on the integrated control board, must be cut if two-stage cooling will be used. If the jumper is not cut the outdoor unit will operate in first-stage cooling only.

Status LEDs (HI/LO, CFM, ANI)

The green HI/LO LED indicates circulating blower speed in response to the DS signal. The LED is lit during normal blower operation and is off during a dehumidification demand.

The green CFM LED indicates the blower air flow. Count the number of blinks between the two-second pauses to determine the air flow. Each blink represents approximately 50 L/s (100CFM).

The red ANI LED flashes diagnostic codes, which are detailed on page 43.

Indoor Fan Operation DIP Switch Settings

Switches 1 and 2 -- Blower Speed Adjustment --

Switches 1 and 2 are used to select blower speed adjustment settings. The unit is shipped from the factory with the DIP switches positioned for NORMAL (no) adjustment. The DIP switches may be positioned to adjust the blower speed by +10% or -10% to better suit the application. The table below provides blower speed adjustments that will result from different switch settings. Refer to tables 14 through NO TAG for corresponding cfm values.

**TABLE 10
Blower Speed Adjustment**

Adjustment	Switch 1	Switch 2
+10% (approx.)	On	Off
NORMAL (Factory)	Off	Off
-10% (approx.)	Off	On

Switches 3 and 4 -- Cooling Mode Blower Speed --

Switches 3 and 4 are used to select cooling blower motor speed. The unit is shipped from the factory with the DIP switches positioned for high speed (4) indoor blower motor operation during the cooling mode. The table below provides the cooling mode blower speeds that will result from different switch settings. Refer to tables 14 through NO TAG for corresponding cfm values.

**TABLE 11
Cooling Mode Blower Speeds**

Speed	Switch 3	Switch 4
1 - Low	On	On
2 - Medium Low	Off	On
3 - Medium High	On	Off
4 - High (Factory)	Off	Off

Switches 5 and 6 -- Cooling Mode Blower Speed Ramping -- Switches 5 and 6 are used to select cooling mode blower speed ramping options. Blower speed ramping may be used to enhance dehumidification performance. The switches are factory set at option A which has the greatest effect on blower motor performance. Table 12 provides the cooling mode blower speed ramping options that will result from different switch settings. The cooling mode blower speed ramping options are detailed on the next page.

NOTE - The off portion of the selected ramp profile also applies during heat pump operation in dual fuel applications.

**TABLE 12
Cooling Mode Blower Speed Ramping**

Ramping Option	Switch 5	Switch 6
A (Factory)	Off	Off
B	On	Off
C	Off	On
D	On	On

Ramping Option A (Factory Selection)

- Motor runs at 50% for 30 seconds.
- Motor then runs at 82% for approximately 7-1/2 minutes.
- If demand has not been satisfied after 7-1/2 minutes, motor runs at 100% until demand is satisfied.
- Once demand is met, motor runs at 50% for 30 seconds then ramps down to stop.

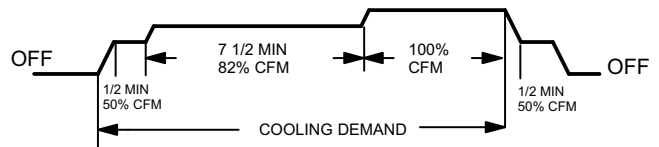

Ramping Option B

- Motor runs at 82% for approximately 7-1/2 minutes. If demand has not been satisfied after 7-1/2 minutes, motor runs at 100% until demand is satisfied.
- Once demand is met, motor ramps down to stop.

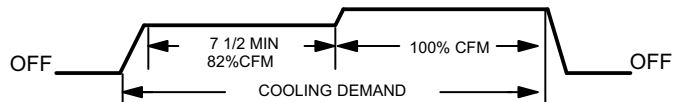

Ramping Option C

- Motor runs at 100% until demand is satisfied.
- Once demand is met, motor runs at 100% for 45 seconds then ramps down to stop.

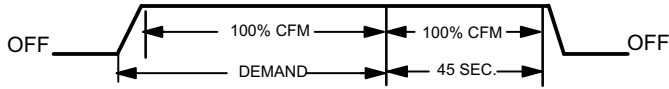

Switches 7 and 8 -- Heating Mode Blower Speed --
 Switches 7 and 8 are used to select heating mode blower motor speed. The unit is shipped from the factory with the dip switches positioned for medium low (2) speed indoor blower motor operation during the heating mode. The table below provides the heating mode blower speeds that will result from different switch settings. Refer to tables 14 through NO TAG for corresponding L/s values.

Ramping Option D

- Motor runs at 100% until demand is satisfied.
- Once demand is met, motor ramps down to stop.

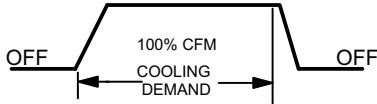

**TABLE 13
 Heating Mode Blower Speeds**

Speed	Switch 7	Switch 8
1 - Low	On	On
2 - Medium Low (Factory)	Off	On
3 - Medium High	On	Off
4 - High	Off	Off

**TABLE 14
 G61MPVT-36B-070 BLOWER MOTOR PERFORMANCE (LESS FILTER)
 0.0" to 0.8" w.g. (0 through 200 Pa) External Static Pressure Range
 Factory Settings: Heating Speed - 2; Cooling Speed - 4; Speed Adjust - NORM**

"ADJUST" Switch Positions	Speed Switch Positions															
	Second Stage "HEAT" Speed								Second Stage "COOL" Speed							
	1		2		3		4		1		2		3		4	
	cfm	L/s	cfm	L/s	cfm	L/s	cfm	L/s	cfm	L/s	cfm	L/s	cfm	L/s	cfm	L/s
+	895	420	1025	485	1290	610	1340	630	1015	480	1190	560	1280	605	1395	660
NORM	820	385	940	445	1155	545	1210	570	930	440	1065	505	1155	545	1270	600
-	N/A	N/A	840	395	1020	480	1055	495	830	390	950	450	1010	475	1105	520

"ADJUST" Switch Positions	First Stage "HEAT" Speed								First Stage "COOL" Speed							
	1		2		3		4		1		2		3		4	
	cfm	L/s	cfm	L/s	cfm	L/s	cfm	L/s	cfm	L/s	cfm	L/s	cfm	L/s	cfm	L/s
+	820	385	930	440	1160	550	1210	570	730	345	815	385	865	410	935	440
NORM	760	360	865	410	1045	495	1090	515	680	320	755	355	795	375	855	405
-	N/A	N/A	775	365	930	440	965	455	625	295	695	330	730	345	775	365

N/A - First and second stage HEAT positions shown cannot be used on this model.

NOTES - The effect of static pressure is included in air volumes shown.

First stage HEAT is approximately 91% of the same second stage HEAT speed position.

First stage COOL (two-stage air conditioning units only) is approximately 70% of the same second stage COOL speed position.

Continuous Fan Only speed is approximately 38% of the same second stage COOL speed position - minimum 500 cfm (235 L/s).

TABLE 15
G61MPVT-60C-090 BLOWER MOTOR PERFORMANCE (LESS FILTER)
0.0" to 0.8" w.g. (0 through 200 Pa) External Static Pressure Range
Factory Settings: Heating Speed - 2; Cooling Speed - 4; Speed Adjust - NORM.
Return Air Options: Bottom; both sides; or bottom and one side.

"ADJUST" Switch Positions	Speed Switch Positions															
	Second Stage "HEAT" Speed								Second Stage "COOL" Speed							
	1		2		3		4		1		2		3		4	
	cfm	L/s	cfm	L/s	cfm	L/s	cfm	L/s	cfm	L/s	cfm	L/s	cfm	L/s	cfm	L/s
+	1500	710	1675	790	1880	885	2090	985	1605	760	1710	805	1925	910	2165	1020
NORM	1355	640	1545	730	1720	810	1900	895	1440	680	1560	735	1755	825	1960	925
—	1194	565	1365	645	1540	730	1695	800	1275	600	1380	650	1590	750	1755	830
"ADJUST" Switch Positions	First Stage "HEAT" Speed								First Stage "COOL" Speed							
	1		2		3		4		1		2		3		4	
	cfm	L/s	cfm	L/s	cfm	L/s	cfm	L/s	cfm	L/s	cfm	L/s	cfm	L/s	cfm	L/s
+	1360	640	1560	735	1730	815	1910	900	1105	520	1185	560	1355	640	1545	730
NORM	1220	575	1405	665	1585	750	1740	820	995	470	1080	510	1205	570	1345	635
—	1105	520	1235	585	1410	665	1570	740	890	420	960	455	1090	515	1215	575

NOTES - The effect of static pressure is included in air volumes shown.
 First stage HEAT is approximately **91%** of the same second stage HEAT speed position.
 First stage COOL (two-stage air conditioning units only) is approximately 70% of the same second stage COOL speed position.
 Continuous Fan Only speed is approximately **38%** of the same second stage COOL speed position - minimum 500 cfm (235 L/s).

TABLE 16
G61MPVT-60C-090 BLOWER MOTOR PERFORMANCE (LESS FILTER)
0.0" to 0.8" w.g. (0 through 200 Pa) External Static Pressure Range
Factory Settings: Heating Speed - 2; Cooling Speed - 4; Speed Adjust - NORM.
Return Air Options: Single side return air - Bold volumes require field-fabricated transition to accommodate
20 x 25 x 1 in. (508 x 635 x 25 mm) cleanable air filter in order to maintain proper air velocity across the filter.

"ADJUST" Switch Positions	Speed Switch Positions															
	Second Stage "HEAT" Speed								Second Stage "COOL" Speed							
	1		2		3		4		1		2		3		4	
	cfm	L/s	cfm	L/s	cfm	L/s	cfm	L/s	cfm	L/s	cfm	L/s	cfm	L/s	cfm	L/s
+	1450	685	1640	775	1820	860	2055	970	1575	745	1690	795	1895	895	2135	1005
NORM	1320	625	1510	710	1700	800	1870	880	1405	665	1530	720	1735	820	1935	910
—	1165	550	1320	625	1500	705	1665	785	1250	590	1355	640	1560	735	1735	820
"ADJUST" Switch Positions	First Stage "HEAT" Speed								First Stage "COOL" Speed							
	1		2		3		4		1		2		3		4	
	cfm	L/s	cfm	L/s	cfm	L/s	cfm	L/s	cfm	L/s	cfm	L/s	cfm	L/s	cfm	L/s
+	1315	620	1510	715	1695	800	1875	885	1080	510	1160	545	1315	620	1490	705
NORM	1190	560	1365	645	1545	730	1715	810	985	465	1060	500	1185	560	1330	625
—	1075	510	1205	570	1370	645	1520	715	865	410	930	440	1065	500	1185	560

NOTES - The effect of static pressure is included in air volumes shown.
 First stage HEAT is approximately **91%** of the same second stage HEAT speed position.
 First stage COOL (two-stage air conditioning units only) is approximately 70% of the same second stage COOL speed position.
 Continuous Fan Only speed is approximately **38%** of the same second stage COOL speed position - minimum 500 cfm (235 L/s).

TABLE 17
G61MPVT-60C-090 BLOWER MOTOR PERFORMANCE (LESS FILTER)
0.0" to 0.8" w.g. (0 through 200 Pa) External Static Pressure Range
Factory Settings: Heating Speed - 2; Cooling Speed - 4; Speed Adjust - NORM.
Return Air Options: Single side return with optional RAB return air base

"ADJUST" Switch Positions	Speed Switch Positions															
	Second Stage "HEAT" Speed								Second Stage "COOL" Speed							
	1		2		3		4		1		2		3		4	
	cfm	L/s	cfm	L/s	cfm	L/s	cfm	L/s	cfm	L/s	cfm	L/s	cfm	L/s	cfm	L/s
+	1440	680	1630	770	1810	855	2015	950	1525	720	1655	780	1860	880	2100	990
NORM	1300	615	1485	700	1655	780	1830	865	1385	655	1500	710	1695	800	1905	900
—	1155	545	1310	620	1480	700	1640	775	1240	585	1320	625	1510	710	1695	800

"ADJUST" Switch Positions	First Stage "HEAT" Speed								First Stage "COOL" Speed							
	1		2		3		4		1		2		3		4	
	cfm	L/s	cfm	L/s	cfm	L/s	cfm	L/s	cfm	L/s	cfm	L/s	cfm	L/s	cfm	L/s
+	1320	625	1490	700	1665	785	1840	870	1060	500	1135	535	1285	605	1455	685
NORM	1180	555	1345	635	1515	715	1680	795	960	455	1035	490	1165	550	1310	620
—	1055	500	1180	560	1340	630	1490	705	865	405	920	435	1050	495	1165	550

NOTES - The effect of static pressure is included in air volumes shown.
 First stage HEAT is approximately 91% of the same second stage HEAT speed position.
 First stage COOL (two-stage air conditioning units only) is approximately 70% of the same second stage COOL speed position.
 Continuous Fan Only speed is approximately 38% of the same second stage COOL speed position - minimum 500 cfm (235 L/s).

TABLE 18
G61MPVT-60C-110 BLOWER MOTOR PERFORMANCE (LESS FILTER)
0.0" to 0.8" w.g. (0 through 200 Pa) External Static Pressure Range
Factory Settings: Heating Speed - 2; Cooling Speed - 4; Speed Adjust - NORM.
Return Air Options: Bottom; both sides; or bottom and one side.

"ADJUST" Switch Positions	Speed Switch Positions															
	Second Stage "HEAT" Speed								Second Stage "COOL" Speed							
	1		2		3		4		1		2		3		4	
	cfm	L/s	cfm	L/s	cfm	L/s	cfm	L/s	cfm	L/s	cfm	L/s	cfm	L/s	cfm	L/s
+	1505	710	1710	805	1915	905	2130	1005	1625	770	1745	825	1990	940	2210	1045
NORM	1370	645	1565	740	1765	835	1945	920	1465	690	1580	745	1790	845	1995	940
—	1205	570	1380	650	1565	740	1740	820	1290	610	1405	660	1605	760	1790	845

"ADJUST" Switch Positions	First Stage "HEAT" Speed								First Stage "COOL" Speed							
	1		2		3		4		1		2		3		4	
	cfm	L/s	cfm	L/s	cfm	L/s	cfm	L/s	cfm	L/s	cfm	L/s	cfm	L/s	cfm	L/s
+	1370	645	1570	740	1760	830	1945	920	945	445	1020	480	1160	545	1300	615
NORM	1235	585	1420	670	1600	755	1780	840	840	395	910	430	1055	500	1180	555
—	1105	525	1250	590	1420	670	1580	745	740	350	800	380	920	435	1045	495

NOTES - The effect of static pressure is included in air volumes shown.
 First stage HEAT is approximately 91% of the same second stage HEAT speed position.
 First stage COOL (two-stage air conditioning units only) is approximately 70% of the same second stage COOL speed position.
 Continuous Fan Only speed is approximately 38% of the same second stage COOL speed position - minimum 500 cfm (235 L/s).

TABLE 19
G61MPVT-60C-110 BLOWER MOTOR PERFORMANCE (LESS FILTER)
0.0" to 0.8" w.g. (0 through 200 Pa) External Static Pressure Range

Factory Settings: Heating Speed - 2; Cooling Speed - 4; Speed Adjust - NORM.

Return Air Options: Single side return air - Bold volumes require field-fabricated transition to accommodate 20 x 25 x 1 in. (508 x 635 x 25 mm) cleanable air filter in order to maintain proper air velocity across the filter.

"ADJUST" Switch Positions	Speed Switch Positions															
	Second Stage "HEAT" Speed								Second Stage "COOL" Speed							
	1		2		3		4		1		2		3		4	
	cfm	L/s	cfm	L/s	cfm	L/s	cfm	L/s	cfm	L/s	cfm	L/s	cfm	L/s	cfm	L/s
+	1485	700	1675	790	1870	885	2080	980	1585	750	1700	800	1905	900	2135	1005
NORM	1350	637	1525	720	1725	815	1895	895	1435	680	1535	725	1740	820	1930	910
—	1175	555	1335	630	1505	710	1670	790	1280	605	1385	655	1570	740	1755	830
"ADJUST" Switch Positions	First Stage "HEAT" Speed								First Stage "COOL" Speed							
	1		2		3		4		1		2		3		4	
	cfm	L/s	cfm	L/s	cfm	L/s	cfm	L/s	cfm	L/s	cfm	L/s	cfm	L/s	cfm	L/s
+	1325	625	1505	710	1695	800	1870	885	935	440	1025	485	1155	545	1285	605
NORM	1195	565	1365	645	1550	730	1720	810	840	395	915	430	1050	495	1175	555
—	1080	510	1205	570	1365	645	1530	720	750	355	800	380	925	435	1050	495

NOTES - The effect of static pressure is included in air volumes shown.
 First stage HEAT is approximately **91%** of the same second stage HEAT speed position.
 First stage COOL (two-stage air conditioning units only) is approximately **70%** of the same second stage COOL speed position.
 Continuous Fan Only speed is approximately **38%** of the same second stage COOL speed position - minimum 500 cfm (235 L/s).

TABLE 20
G61MPVT-60C-110 BLOWER MOTOR PERFORMANCE (LESS FILTER)
0.0" to 0.8" w.g. (0 through 200 Pa) External Static Pressure Range

Factory Settings: Heating Speed - 2; Cooling Speed - 4; Speed Adjust - NORM.

Return Air Options: Single side return air with optional RAB return base. - 20 x 25 x 1 in. (508 x 635 x 25 mm) cleanable air filter in order to maintain proper air velocity across the filter.

"ADJUST" Switch Positions	Speed Switch Positions															
	Second Stage "HEAT" Speed								Second Stage "COOL" Speed							
	1		2		3		4		1		2		3		4	
	cfm	L/s	cfm	L/s	cfm	L/s	cfm	L/s	cfm	L/s	cfm	L/s	cfm	L/s	cfm	L/s
+	1475	695	1670	790	1865	880	2070	980	1555	735	1685	795	1895	895	2130	1005
NORM	1345	635	1500	710	1695	800	1865	880	1415	670	1540	725	1735	820	1930	910
—	1180	555	1345	635	1510	710	1685	795	1245	590	1350	635	1545	730	1725	815
"ADJUST" Switch Positions	First Stage "HEAT" Speed								First Stage "COOL" Speed							
	1		2		3		4		1		2		3		4	
	cfm	L/s	cfm	L/s	cfm	L/s	cfm	L/s	cfm	L/s	cfm	L/s	cfm	L/s	cfm	L/s
+	1330	625	1510	715	1695	800	1875	885	1085	510	1155	545	1310	620	1475	695
NORM	1195	565	1375	650	1550	730	1725	815	955	450	1050	495	1185	560	1335	630
—	1080	510	1210	570	1370	645	1520	715	850	400	920	435	1070	505	1195	565

NOTES - The effect of static pressure is included in air volumes shown.
 First stage HEAT is approximately **91%** of the same second stage HEAT speed position.
 First stage COOL (two-stage air conditioning units only) is approximately **70%** of the same second stage COOL speed position.
 Continuous Fan Only speed is approximately **38%** of the same second stage COOL speed position - minimum 500 cfm (235 L/s).

TABLE 21
G61MPVT-60D-135 BLOWER MOTOR PERFORMANCE (LESS FILTER)
0.0" to 0.8" w.g. (0 through 200 Pa) External Static Pressure Range
Factory Settings: Heating Speed - 2; Cooling Speed - 4; Speed Adjust - NORM.
Return Air Options: Bottom.

"ADJUST" Switch Positions	Speed Switch Positions															
	Second Stage "HEAT" Speed								Second Stage "COOL" Speed							
	1		2		3		4		1		2		3		4	
	cfm	L/s	cfm	L/s	cfm	L/s	cfm	L/s	cfm	L/s	cfm	L/s	cfm	L/s	cfm	L/s
+	1505	710	1705	805	1900	900	2110	995	1615	760	1730	815	1945	920	2190	1035
NORM	1365	645	1550	730	1740	820	1920	905	1455	685	1580	745	1780	840	1985	935
—	1225	580	1380	650	1545	730	1720	810	1305	615	1400	660	1600	755	1780	840
"ADJUST" Switch Positions	First Stage "HEAT" Speed								First Stage "COOL" Speed							
	1		2		3		4		1		2		3		4	
	cfm	L/s	cfm	L/s	cfm	L/s	cfm	L/s	cfm	L/s	cfm	L/s	cfm	L/s	cfm	L/s
+	1385	655	1570	740	1760	830	1930	910	1135	535	1205	570	1365	645	1540	725
NORM	1250	590	1425	670	1595	755	1775	835	1025	485	1105	520	1235	580	1390	655
—	1135	535	1265	595	1430	675	1585	750	915	430	985	465	1115	525	1235	585

NOTES - The effect of static pressure is included in air volumes shown.
 First stage HEAT is approximately **91%** of the same second stage HEAT speed position.
 First stage COOL (two-stage air conditioning units only) is approximately **70%** of the same second stage COOL speed position.
 Continuous Fan Only speed is approximately **38%** of the same second stage COOL speed position - minimum 500 cfm (235 L/s).

Unit Start-Up

FOR YOUR SAFETY READ BEFORE OPERATING

⚠ WARNING

Do not use this furnace if any part has been under water. A flood-damaged furnace is extremely dangerous. Attempts to use the furnace can result in fire or explosion. Immediately call a qualified service technician to inspect the furnace and to replace all gas controls, control system parts, and electrical parts that have been wet or to replace the furnace, if deemed necessary.

⚠ WARNING



Danger of explosion. Can cause injury or product or property damage. Should the gas supply fail to shut off or if overheating occurs, shut off the gas valve to the furnace before shutting off the electrical supply.

⚠ CAUTION

Before attempting to perform any service or maintenance, turn the electrical power to unit OFF at disconnect switch.

Priming Condensate Trap

The condensate trap should be primed with water prior to start-up to ensure proper condensate drainage. Either pour 10 fl. oz. (300 ml) of water into the trap, or follow these steps to prime the trap:

- 1 - Follow the lighting instructions to place the unit into operation.
- 2 - Set the thermostat to initiate a heating demand.
- 3 - Allow the burners to fire for approximately 3 minutes.
- 4 - Adjust the thermostat to deactivate the heating demand.
- 5 - Wait for the combustion air inducer to stop. Set the thermostat to initiate a heating demand and again allow the burners to fire for approximately 3 minutes.
- 6 - Adjust the thermostat to deactivate the heating demand and again wait for the combustion air inducer to stop. At this point, the trap should be primed with sufficient water to ensure proper condensate drain operation.

BEFORE LIGHTING the unit, smell all around the furnace area for gas. Be sure to smell next to the floor because some gas is heavier than air and will settle on the floor.

The gas valve on the G61MPVT is equipped with a gas control knob. Use only your hand to turn the gas control knob. Never use tools. If the knob will not push in or turn by hand, do not try to repair it. Call a qualified service technician. Force or attempted repair may result in a fire or explosion.

Placing the furnace into operation:

G61MPVT units are equipped with an automatic ignition system. Do not attempt to manually light burners on this furnace. Each time the thermostat calls for heat, the burners will automatically light. The ignitor does not get hot when there is no call for heat on units with this ignition system.

⚠ WARNING

If you do not follow these instructions exactly, a fire or explosion may result causing property damage, personal injury or death.

Gas Valve Operation (Figure 34)

- 1 - **STOP!** Read the safety information at the beginning of this section.
- 2 - Set the thermostat to the lowest setting.
- 3 - Turn off all electrical power to the unit.
- 4 - This furnace is equipped with an ignition device which automatically lights the burners. Do **not** try to light the burners by hand.
- 5 - Remove the upper access panel.
- 6 - *Honeywell VR8205 Gas Valve* - Turn knob on gas valve clockwise  to **OFF**. Do not force. See figure 34.
- 7 - Wait five minutes to clear out any gas. If you then smell gas, **STOP!** Immediately call your gas supplier from a neighbor's phone. Follow the gas supplier's instructions. If you do not smell gas go to next step.

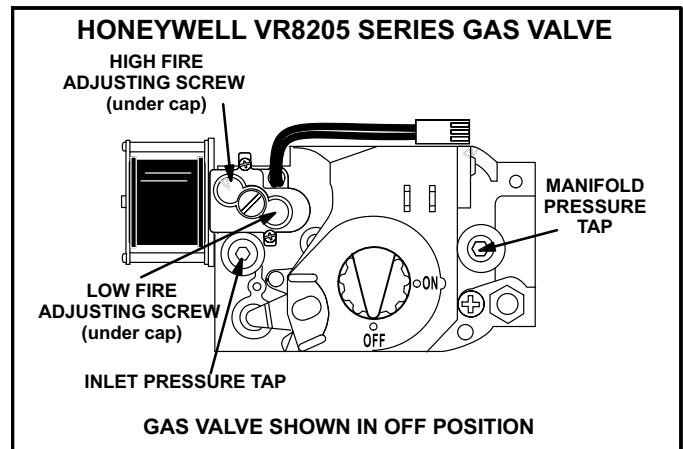



FIGURE 34

- 8 - *Honeywell VR8205 Gas Valve* - Turn knob on gas valve counterclockwise  to **ON**. Do not force.
- 9 - Replace the upper access panel.
- 10- Turn on all electrical power to the unit.

11- Set the thermostat to desired setting.

NOTE - When unit is initially started, steps 1 through 11 may need to be repeated to purge air from gas line.

12- If the appliance will not operate, follow the instructions "Turning Off Gas to Unit" and call your service technician or gas supplier.

Turning Off Gas to Unit

- 1 - Set the thermostat to the lowest setting.
- 2 - Turn off all electrical power to the unit if service is to be performed.
- 3 - Remove the upper access panel.
- 4 - *Honeywell VR8205 Gas Valve* - Turn knob on gas valve clockwise  to **OFF**. Do not force.
- 5 - Replace the upper access panel.

Gas Pressure Adjustment

Gas Flow (Approximate)

- 1 - Operate unit at least 15 minutes before checking gas flow. Determine the time in seconds for one revolutions of gas through the meter.

TABLE 22

Gas Flow Rate (Ft. ³ /Hr.)		
Seconds for 1 Revolution	Gas Meter Size	
	1/2 cu ft Dial	1 cu ft Dial
10	180	360
12	150	300
14	129	257
16	113	225
18	100	200
20	90	180
22	82	164
24	75	150
26	69	138
28	64	129
30	60	120
32	56	113
34	53	106
36	50	100
38	47	95
40	45	90
42	43	86
44	41	82
46	39	78
48	38	75
50	36	72
52	35	69
54	33	67
56	32	64
58	31	62
60	30	60

- 2 - Compare the number of seconds and the gas meter size in table 22 to determine the gas flow rate. Multiply the gas flow rate by the heating value to determine the unit input rate. If manifold pressure is correct and the unit input rate is incorrect, check gas orifices for proper size and restriction.

3 - Remove temporary gas meter if installed.

NOTE - To obtain accurate reading, shut off all other gas appliances connected to meter.

Manifold Pressure Measurement & Adjustment

NOTE - Pressure test adapter kit (10L34) is available from Lennox to facilitate manifold pressure measurement.

- 1 - Connect test gauge to outlet tap on gas valve.
- 2 - Disconnect pressure sensing hose from barbed fitting on gas valve. Use an obstruction to plug the hose.
- 3 - Start unit on low heat and allow 5 minutes for unit to reach steady state.
- 4 - While waiting for the unit to stabilize, notice the flame. Flame should be stable and should not lift from burner. Natural gas should burn blue.
- 5 - After allowing unit to stabilize for 5 minutes, record manifold pressure and compare to value given in table 23.
- 6 - Repeat steps 3, 4 and 5 on high heat.

NOTE - Shut unit off and remove manometer as soon as an accurate reading has been obtained. Take care to replace pressure tap plug.

NOTE - During this test procedure, the unit will be overfiring:

- Operate unit only long enough to obtain accurate reading to prevent overheating heat exchanger.
 - Attempts to clock gas meter during this procedure will be inaccurate. Measure gas flow rate only during normal unit operation.
- 7 - When test is complete remove obstruction from hose and return hose to barbed fitting on gas valve.

Manifold Pressure and High Altitude Information

The units are factory-ready for use with natural gas. If LP/propane fuel use is required, a conversion kit must be installed.

NOTE - A natural to L.P. propane gas changeover kit is necessary to convert this unit. Refer to the changeover kit installation instruction for the conversion procedure.

Refer to table 23 for proper gas conversion kits and high altitude pressure switch kits at varying altitudes. Table 24 lists high fire manifold pressure settings at varying altitudes.

The combustion air pressure switches are factory-set and require no adjustment.

TABLE 23
Conversion Kit Requirements
for Models -070, -090, -110 and -135

Model Input Size	High Altitude Pressure Switch Kit ORDER TWO EACH		Natural Gas to LPG / Propane Kit		LPG / Propane Gas to Natural Gas Kit	
	611 - 1372 m		0 - 610 m		611 - 1372 m	
-070	59M17	56M23	N/A	No change	N/A	No Change
	59M14	56M23	59M13	No change	59M13	No Change
-090	59M17	56M21	N/A	No change	N/A	75M22
	59M14	56M21	59M13	No change	59M13	75M22
-110	59M17	75M22	N/A	No change	N/A	56M23
	59M14	75M22	59M13	No change	59M13	56M23
-135	59M17	56M93	N/A	No change	N/A	56M93
	59M14	56M93	59M13	No change	59M13	56M93

NOTE - Pressure switch is factory set. No adjustment necessary. All models use the factory installed pressure switch from 0-4500 feet (0-1372 m).
 *Two pressure switch assemblies required per unit.

TABLE 24

Fuel	Manifold Pressure (Outlet) at High Fire - kPa Altitude - m			
	0-610	¹ 611-914	¹ 915-1219	¹ 1220-1372
Natural	0.87	0.80	0.75	0.70
² LPG/Propane	2.49	2.29	2.12	2.02

¹High Altitude Pressure Switch Kits required for certain models, see Gas Heat Accessories table for order number.

²LPG/Propane conversion kit required, see Gas Heat Accessories table for order number.

Other Unit Adjustments

Primary and Secondary Limits

The primary limit is located on the heating compartment vestibule panel. The secondary limits are located in the blower compartment, attached to the back side of the blower. These limits are factory set and require no adjustment.

Flame Rollout Switches (Two)

These manually reset switches are located on the burner box. If tripped, check for adequate combustion air before resetting.

Pressure Switches (Two or Four)

The pressure switches are located in the heating compartment on the combustion air inducer. These switches check for proper combustion air inducer operation before allowing ignition trial. The switches are factory-set and require no adjustment.

Back-Up Secondary Limit (090, 110 & 135 Models)

The back-up secondary limit is located on the combustion air inducer. This switch protects the plastic components from overheating due to indoor blower motor failure. If tripped, check for proper blower operation before resetting.

Temperature Rise

After the furnace has been started and supply and return air temperatures have been allowed to stabilize, check the temperature rise. If necessary, adjust the blower speed to maintain the temperature rise within the range shown on the unit nameplate. Increase the blower speed to decrease the temperature. Decrease the blower speed to increase the temperature rise. Failure to do adjust the temperature rise may cause erratic limit operation.

Thermostat Heat Anticipation

Set the heat anticipator setting (if adjustable) according to the amp draw listed on the wiring diagram that is attached to the unit.

Electrical

- 1 - Check all wiring for loose connections.
- 2 - Check for the correct voltage at the furnace (furnace operating).
- 3 - Check amp-draw on the blower motor.
 Motor Nameplate _____ Actual _____

NOTE - Do not secure the electrical conduit directly to the air ducts or structure.

Electronic Ignition

The integrated control has an added feature of an internal Watchguard control. The feature serves as an automatic reset device for ignition control lockout caused by ignition failure. This type of lockout is usually due to low gas line pressure. After one hour of continuous thermostat demand for heat, the Watchguard will break and remake thermostat demand to the furnace and automatically reset the control to begin the ignition sequence.

Exhaust and Air Intake Pipe

- 1 - Check exhaust and air intake connections for tightness and to make sure there is no blockage.
- 2 - Are pressure switches closed? Obstructed exhaust pipe will cause unit to shut off at pressure switches. Check exhaust pipe and termination for blockages.
- 3 - Reset manual flame rollout switches on burner box cover.

Failure To Operate

If the unit fails to operate, check the following:

- 1 - Is the thermostat calling for heat?
- 2 - Are access panels securely in place?
- 3 - Is the main disconnect switch closed?
- 4 - Is there a blown fuse?
- 5 - Is the filter dirty or plugged? Dirty or plugged filters will cause the limit control to shut the unit off.
- 6 - Is gas turned on at the meter?
- 7 - Is the manual main shut-off valve open?
- 8 - Is the internal manual shut-off valve open?
- 9 - Is the unit ignition system in lock out? If the unit locks out again, call the service technician to inspect the unit for blockages.

Heating Sequence of Operation

NOTE - The heat staging jumper on the control board is factory-set in the NONE (or no delay) position.

Applications Using a Two-Stage Thermostat

A - Heating Sequence -- Control Board Heat Staging Jumper in NONE Position (Factory Setting)

- 1 - On a call for heat, thermostat first-stage contacts close sending a signal to the integrated control. The integrated control runs a self-diagnostic program and checks high temperature limit switches for normally closed contacts and pressure switches for normally open contacts. The combustion air inducer is energized at low speed and the humidifier terminal is energized.
- 2 - Once the control receives a signal that the low pressure switch has closed, the combustion air inducer begins a 15-second pre-purge in low speed.
- 3 - After the pre-purge is complete, a 20-second initial ignitor warm-up period begins. The combustion air inducer continues to operate at low speed.
- 4 - After the 20-second warm-up period has ended, the gas valve is energized on low fire (first stage) and ignition occurs. At the same time, the control module sends a signal to begin an indoor blower 45-second ON-delay.

When the delay ends, the indoor blower motor is energized on the low fire heating speed. The furnace will continue this operation as long as the thermostat has a first-stage heating demand.

- 5 - If second-stage heat is required, the thermostat second-stage heat contacts close and send a signal to the integrated control.
- 6 - The integrated control energizes the combustion air inducer at high speed. The control also checks the high-fire (second stage) pressure switch to make sure it is closed. Once the the control receives a signal that the high-fire pressure switch is close, the high-fire (second stage) gas valve is energized and the indoor blower motor is energized for operation at the high-fire heating speed.
- 7 - When the demand for high-fire (second stage) heat is satisfied, the combustion air inducer is switched to the low-fire heating speed and the high-fire (second stage) gas valve is de-energized. The low-fire (first stage) gas valve continues operation. The indoor blower motor is switched to the low-fire heating speed.
- 8 - When the thermostat demand for low-fire (first stage) heat is satisfied, the gas valve is de-energized and the field-selected indoor blower off delay begins. The combustion air inducer begins a 5-second post-purge period.
- 9 - When the combustion air post-purge period is complete, the inducer and humidifier terminal are de-energized. The indoor blower is de-energized at the end of the off delay.

Applications Using A Single-Stage Thermostat

B - Heating Sequence -- Control Board Heat Staging Jumper in Either 10-Minute or 15-Minute Stage Delay Position

NOTE - In these applications, two-stage heat will be initiated by the integrated control if heating demand has not been satisfied after the field adjustable period (10 or 15 minutes).

- 1 - On a call for heat, thermostat first-stage contacts close sending a signal to the integrated control. The integrated control runs a self-diagnostic program and checks high temperature limit switches for normally closed contacts and pressure switches for normally open contacts. The combustion air inducer is energized at low speed and the humidifier terminal is energized.
- 2 - Once the control receives a signal that the low pressure switch has closed, the combustion air inducer begins a 15-second pre-purge in low speed.
- 3 - After the pre-purge is complete, a 20-second initial ignitor warm-up period begins. The combustion air inducer continues to operate at low speed.
- 4 - After the 20-second warm-up period has ended, the gas valve is energized on low fire (first stage) and ignition occurs. At the same time, the control module sends a signal to begin an indoor blower 45-second ON-delay. When the delay ends, the indoor blower motor is energized on the low-fire heating speed. The integrated control also initiates a second-stage on delay of either 10 minutes or 15 minutes.

- 5 - If the heating demand continues beyond the second-stage on delay, the integrated control energizes the combustion air inducer at high speed. The control also checks the high-fire (second stage) pressure switch to make sure it is closed. Once the control receives a signal the high-fire pressure switch is closed, the high-fire (second stage) gas valve is energized and the indoor blower motor is energized for operation at the high-fire heating speed.
- 6 - When the thermostat heating demand is satisfied, the combustion air inducer begins a 5-second post-purge. The field-selected indoor blower off delay begins.
- 7 - When the combustion air post-purge period is complete, the inducer and humidifier terminal are de-energized. The indoor blower is de-energized at the end of the off delay.

Service

WARNING

ELECTRICAL SHOCK, FIRE, OR EXPLOSION HAZARD.

Failure to follow safety warnings exactly could result in dangerous operation, serious injury, death or property damage.

Improper servicing could result in dangerous operation, serious injury, death, or property damage.

Before servicing, disconnect all electrical power to furnace.

When servicing controls, label all wires prior to disconnecting. Take care to reconnect wires correctly. Verify proper operation after servicing.

At the beginning of each heating season, system should be checked as follows by a qualified service technician:

Blower

Check the blower wheel for debris and clean if necessary. The blower motors are prelubricated for extended bearing life. No further lubrication is needed.

WARNING

The blower access panel must be securely in place when the blower and burners are operating. Gas fumes, which could contain carbon monoxide, can be drawn into living space resulting in personal injury or death.

Filters

All G61MPVT filters are installed external to the unit. Filters should be inspected monthly. Clean or replace the filters when necessary to ensure proper furnace operation. Table 3 lists recommended filter sizes.

Exhaust and air intake pipes

Check the exhaust and air intake pipes and all connections for tightness and to make sure there is no blockage.

Electrical

- 1 - Check all wiring for loose connections.
- 2 - Check for the correct voltage at the furnace (furnace operating).
- 3 - Check amp-draw on the blower motor.
Motor Nameplate _____ Actual _____

Cleaning Heat Exchanger

If cleaning the heat exchanger becomes necessary, follow the below procedures and refer to figure 1 when disassembling unit. Use papers or protective covering in front of furnace while removing heat exchanger assembly.

- 1 - Turn off electrical and gas supplies to the furnace.
- 2 - Remove the upper and lower furnace access panels.
- 3 - Mark all gas valve wires and disconnect them from valve.
- 4 - Remove gas supply line connected to gas valve. Remove gas valve/manifold assembly.
- 5 - Remove sensor wire from sensor. Disconnect 2-pin plug from the ignitor.
- 6 - Disconnect wires from flame roll-out switches.
- 7 - Remove burner box cover and remove four burner box screws at the vestibule panel and remove burner box. Set burner box assembly aside.
NOTE - G61MPVT-135 units are secured to the vestibule panel by two additional screws. These screws must be removed for servicing; however it is not necessary to replace the screws.
NOTE - If necessary, clean burners at this time. Follow procedures outlined in Burner Cleaning section.
- 8 - Loosen three clamps and remove flexible exhaust tee.
- 9 - Remove 3/8 inch rubber cap from condensate drain plug and drain. Replace cap after draining.
- 10 - Disconnect condensate drain line from the condensate trap. Remove condensate trap (it may be necessary to cut drain pipe). Remove screws that secure condensate collars to either side of the furnace and remove collars. Remove drain tubes from cold end header collector box.
- 11 - Disconnect condensate drain tubing from flue collar. Remove screws that secure both flue collars into place. Remove flue collars. It may be necessary to cut the exiting exhaust pipe for removal of the fittings.
- 12 - Mark and disconnect all combustion air pressure tubing from cold end header collector box.
- 13 - Mark and remove wires from pressure switches. Remove pressure switches. Keep tubing attached to pressure switches.
- 14 - Disconnect the 3-pin plug from the combustion air inducer. Disconnect the two wires to the backup secondary limit, if applicable. Remove four screws which secure combustion air inducer to collector box. Remove combustion air inducer assembly. Remove ground wire from vest panel.
- 15 - Remove electrical junction box from the side of the furnace.

- 16 - Mark and disconnect any remaining wiring to heating compartment components. Disengage strain relief bushing and pull wiring and bushing through the hole in the blower deck.
 - 17 - Remove the primary limit from the vestibule panel.
 - 18 - Remove two screws from the front cabinet flange at the blower deck. Spread cabinet sides slightly to allow clearance for removal of heat exchanger.
 - 19 - Remove screws along vestibule sides and bottom which secure vestibule panel and heat exchanger assembly to cabinet. Remove two screws from blower rail which secure bottom heat exchanger flange. Remove heat exchanger from furnace cabinet.
 - 20 - Back wash heat exchanger with soapy water solution or steam. **If steam is used it must be below 135°C (275°F).**
 - 21 - Thoroughly rinse and drain the heat exchanger. Soap solutions can be corrosive. Take care to rinse entire assembly.
 - 22 - Reinstall heat exchanger into cabinet making sure that the clamshells of the heat exchanger assembly are resting on the support located at the rear of the cabinet. Remove the indoor blower to view this area through the blower opening.
 - 23 - Re-secure the supporting screws along the vestibule sides and bottom to the cabinet.
 - 24 - Reinstall cabinet screws on front flange at blower deck.
 - 25 - Reinstall the primary limit on the vestibule panel.
 - 26 - Route heating component wiring through hole in blower deck and reinsert strain relief bushing.
 - 27 - Reinstall electrical junction box.
 - 28 - Reinstall the combustion air inducer. Reconnect the 3-pin plug to the wire harness. Reconnect the two wires to the backup secondary limit, if applicable.
 - 29 - Reinstall pressure switches and reconnect pressure switch wiring.
 - 30 - Carefully connect combustion air pressure switch hosing from pressure switches to proper stubs on cold end header collector box.
 - 31 - Reinstall condensate collars on each side of the furnace. Reconnect drain tubing to collector box.
 - 32 - Reinstall condensate trap on same side as exhaust pipe. Reconnect condensate drain line to the condensate trap.
 - 33 - Use securing screws to reinstall flue collars to either side of the furnace. Reconnect exhaust piping and exhaust drain tubing.
 - 34 - Replace flexible exhaust tee on combustion air inducer and flue collars. Secure using three existing hose clamps.
 - 35 - Reinstall burner box assembly in vestibule area.
 - 36 - Reconnect flame roll-out switch wires.
 - 37 - Reconnect sensor wire and reconnect 2-pin plug from ignitor.
 - 38 - Secure burner box assembly to vestibule panel using four existing screws. **Make sure burners line up in center of burner ports.**
 - 39 - Reinstall gas valve manifold assembly. Reconnect gas supply line to gas valve.
 - 40 - Reinstall burner box cover.
 - 41 - Reconnect wires to gas valve.
 - 42 - Replace the blower compartment access panel.
 - 43 - Refer to instruction on verifying gas and electrical connections when re-establishing supplies.
 - 44 - Follow lighting instructions to light and operate furnace for 5 minutes to ensure that heat exchanger is clean and dry and that furnace is operating properly.
 - 45 - Replace heating compartment access panel.
- Cleaning the Burner Assembly**
- 1 - Turn off electrical and gas power supplies to furnace. Remove upper and lower furnace access panels.
 - 2 - Mark all gas valve wires and disconnect them from the valve.
 - 3 - Disconnect the gas supply line from the gas valve. Remove gas valve/manifold assembly.
 - 4 - Mark and disconnect sensor wire from the sensor. Disconnect 2-pin plug from the ignitor at the burner box.
 - 5 - Remove burner box cover and remove four screws which secure burner box assembly to vest panel. Remove burner box from the unit.
NOTE - G61MPVT-135 units are secured to the vestibule panel by two additional screws. These screws must be removed for servicing; however it is not necessary to replace the screws.
 - 6 - Use the soft brush attachment on a vacuum cleaner to gently clean the face of the burners. Visually inspect the inside of the burners and crossovers for any blockage caused by foreign matter. Remove any blockage.
 - 7 - Reconnect the sensor wire and reconnect the 2-pin plug to the ignitor wiring harness.
 - 8 - Reinstall the burner box assembly using the existing four screws. Make sure that the burners line up in the center of the burner ports.
 - 9 - Reinstall the gas valve manifold assembly. Reconnect the gas supply line to the gas valve. Reinstall the burner box cover.
 - 10 - Reconnect the gas valve wires to the gas valve.
 - 11 - Replace the blower compartment access panel.
 - 12 - Refer to instruction on verifying gas and electrical connections when re-establishing supplies.
 - 13 - Follow lighting instructions to light and operate furnace for 5 minutes to ensure that heat exchanger is clean and dry and that furnace is operating properly.
 - 14 - Replace heating compartment access panel.

Requirements

Use only the type of gas approved for use with this furnace. Refer to unit nameplate.

G61MPVT units are certified for installation clearances to combustible material as listed on the unit nameplate and in the tables in figures 3, 9 and 6. Accessibility and service clearances must take precedence over fire protection clearances.

NOTE - For installation on combustible floors, the furnace shall not be installed directly on carpeting, tile, or other combustible material other than wood flooring.

For installation in a residential garage, the furnace must be installed so that the burner(s) and the ignition source are located no less than 457mm (18 inches) above the floor. The furnace must be located or protected to avoid physical damage by vehicles. When a furnace is installed in a public garage, hangar, or other building that has a hazardous atmosphere, the furnace must be installed according to recommended good practice requirements and current National Fuel Gas Code or AS 5601 standard.

NOTE - Furnace must be adjusted to obtain a temperature rise within the range specified on the unit nameplate. Failure to do so may cause erratic limit operation.

This G61MPVT furnace must be installed so that its electrical components are protected from water.

When this furnace is used with cooling units, it shall be installed in parallel with, or on the upstream side of, cooling units to avoid condensation in the heating compartment. With a parallel flow arrangement, a damper (or other means to control the flow of air) must adequately prevent chilled air from entering the furnace. If the damper is manually operated, it must be equipped to prevent operation of either the heating or the cooling unit, unless it is in the full **HEAT** or **COOL** setting.

When installed, this furnace must be electrically grounded according to local codes.

NOTE - This furnace is designed for a minimum continuous return air temperature of 16°C (60°F) or an intermittent operation down to 13°C (55°F) dry bulb for cases where a night setback thermostat is used. Return air temperature must not exceed 29°C (85°F) dry bulb.

The G61MPVT furnace may be installed in alcoves, closets, attics, basements, garages, and utility rooms. This furnace design has not been certified for installation in mobile homes, recreational vehicles, or outdoors.

Never use an open flame to test for gas leaks. Check all connections using a commercially available soap solution made specifically for leak detection.

Lennox does not recommend the use of G61MPVT units as a construction heater during any phase of construction. Very low return air temperatures, harmful vapors and operation of the unit with clogged or misplaced filters will damage the unit.

G61MPVT units may be used for heating of buildings or structures under construction, if the following conditions are met:

- *The vent system must be permanently installed per these installation instructions.*
- *A room thermostat must control the furnace. The use of fixed jumpers that will provide continuous heating is not allowed.*
- *The return air duct must be provided and sealed to the furnace.*
- *Return air temperature range between 16°C (60°F) and 27°C (80°F) must be maintained.*
- *Air filters must be installed in the system and must be maintained during construction.*
- *Air filters must be replaced upon construction completion.*
- *The input rate and temperature rise must be set per the furnace rating plate.*
- *One hundred percent (100%) outdoor air must be provided for combustion air requirements during construction. Temporary ducting may supply outdoor air to the furnace. Do not connect duct directly to the furnace. Size the temporary duct following these instructions in section for Combustion, Dilution and Ventilation Air in a confined space with air from outside.*
- *The furnace heat exchanger, components, duct system, air filters and evaporator coils must be thoroughly cleaned following final construction clean-up.*
- *All furnace operating conditions (including ignition, input rate, temperature rise and venting) must be verified according to these installation instructions.*

General

These instructions are intended as a general guide and do not supersede local codes in any way. Consult authorities having jurisdiction before installation.

In addition to the requirements outlined previously, the following general recommendations must be considered when installing a G61MPVT furnace:

- Place the furnace as close to the center of the air distribution system as possible. The furnace should also be located close to the chimney or vent termination point.
- When the furnace is installed in non-direct vent applications, do not install the furnace where drafts might blow directly into it. This could cause improper combustion and unsafe operation.
- When the furnace is installed in non-direct vent applications, do not block the furnace combustion air opening with clothing, boxes, doors, etc. Air is needed for proper combustion and safe unit operation.

- When the furnace is installed in an attic or other insulated space, keep insulation away from the furnace.
- When the furnace is installed in an unconditioned space, consider provisions required to prevent freezing of condensate drain system.

⚠ CAUTION

G61MPVT unit should not be installed in areas normally subject to freezing temperatures.

⚠ WARNING

Product contains fiberglass wool.

Disturbing the insulation in this product during installation, maintenance, or repair will expose you to fiberglass wool.

Fiberglass wool may also cause respiratory, skin, and eye irritation.

To reduce exposure to this substance or for further information, consult material safety data sheets available from address shown below, or contact your supervisor.

**Lennox Industries Inc.
P.O. Box 799900
Dallas, TX 75379-9900**

Combustion, Dilution & Ventilation Air

If the G61MPVT is installed as a Non-Direct Vent Furnace, follow the guidelines in this section.

NOTE - In Non-Direct Vent installations, combustion air is taken from indoors and flue gases are discharged outdoors.

⚠ WARNING

Insufficient combustion air can cause headaches, nausea, dizziness or asphyxiation. It will also cause excess water in the heat exchanger resulting in rusting and premature heat exchanger failure. Excessive exposure to contaminated combustion air will result in safety and performance related problems. Avoid exposure to the following substances in the combustion air supply:

**Permanent wave solutions
Chlorinated waxes and cleaners
Chlorine base swimming pool chemicals
Water softening chemicals
De-icing salts or chemicals
Carbon tetrachloride
Halogen type refrigerants
Cleaning solvents (such as perchloroethylene)
Printing inks, paint removers, varnishes, etc.
Hydrochloric acid
Cements and glues
Antistatic fabric softeners for clothes dryers
Masonry acid washing materials**

In the past, there was no problem in bringing in sufficient outdoor air for combustion. Infiltration provided all the air that was needed. In today's homes, tight construction practices make it necessary to bring in air from outside for combustion. Take into account that exhaust fans, appliance vents, chimneys, and fireplaces force additional air that could be used for combustion out of the house. Unless outside air is brought into the house for combustion, negative pressure (outside pressure is greater than inside pressure) will build to the point that a downdraft can occur in the furnace vent pipe or chimney. As a result, combustion gases enter the living space creating a potentially dangerous situation.

In the absence of local codes concerning air for combustion and ventilation, use the guidelines and procedures in this section to install G61MPVT furnaces to ensure efficient and safe operation. You must consider combustion air needs and requirements for exhaust vents and gas piping. A portion of this information has been reprinted with permission from the National Fuel Gas Code (ANSI-Z223.1/NFPA 54). This reprinted material is not the complete and official position of the ANSI on the referenced subject, which is represented only by the standard in its entirety.

In Australia, refer to the standard AS 5601-2004 Gas Installation Code.

⚠ CAUTION

Do not install the furnace in a corrosive or contaminated atmosphere. Meet all combustion and ventilation air requirements, as well as all local codes.

All gas-fired appliances require air for the combustion process. If sufficient combustion air is not available, the furnace or other appliance will operate inefficiently and unsafely. Enough air must be provided to meet the needs of all fuel-burning appliances and appliances such as exhaust fans which force air out of the house. When fireplaces, exhaust fans, or clothes dryers are used at the same time as the furnace, much more air is required to ensure proper combustion and to prevent a downdraft. Insufficient air causes incomplete combustion which can result in carbon monoxide.

In addition to providing combustion air, fresh outdoor air dilutes contaminants in the indoor air. These contaminants may include bleaches, adhesives, detergents, solvents and other contaminants which can corrode furnace components.

The requirements for providing air for combustion and ventilation depend largely on whether the furnace is installed in an unconfined or a confined space.

Unconfined Space

An unconfined space is an area such as a basement or large equipment room with a volume greater than 1.42 m³ per .29 kW (50 cubic feet per 1,000Btu) per hour of the combined input rating of all appliances installed in that space. This space also includes adjacent rooms which are not separated by a door. Though an area may appear to be unconfined, it might be necessary to bring in outdoor air for combustion if the structure does not provide enough air by infiltration. If the furnace is located in a building of tight construction with weather stripping and caulking around the windows and doors, follow the procedures in the air from outside section.

Confined Space

A confined space is an area with a volume less than 1.42 m³ per .29 kW (50 cubic feet per 1,000Btu) per hour of the combined input rating of all appliances installed in that space. This definition includes furnace closets or small equipment rooms.

When the furnace is installed so that supply ducts carry air circulated by the furnace to areas outside the space containing the furnace, the return air **must be** handled by ducts which are sealed to the furnace casing and which terminate outside the space containing the furnace. This is especially important when the furnace is mounted on a platform in a confined space such as a closet or small equipment room. Even a small leak around the base of the unit at the platform or at the return air duct connection can cause a potentially dangerous negative pressure condition. Air for combustion and ventilation can be brought into the confined space either from inside the building or from outside.

Air from Inside

If the confined space that houses the furnace adjoins a space categorized as unconfined, air can be brought in by providing two permanent openings between the two spaces. Each opening must have a minimum free area of 645 mm² per .29 kW (1 square inch per 1,000Btu) per hour

of total input rating of all gas-fired equipment in the confined space. Each opening must be at least 64516 mm² (100 square inches). One opening shall be within 305 mm (12 inches) of the top of the enclosure and one opening within 305 mm (12 inches) of the bottom.

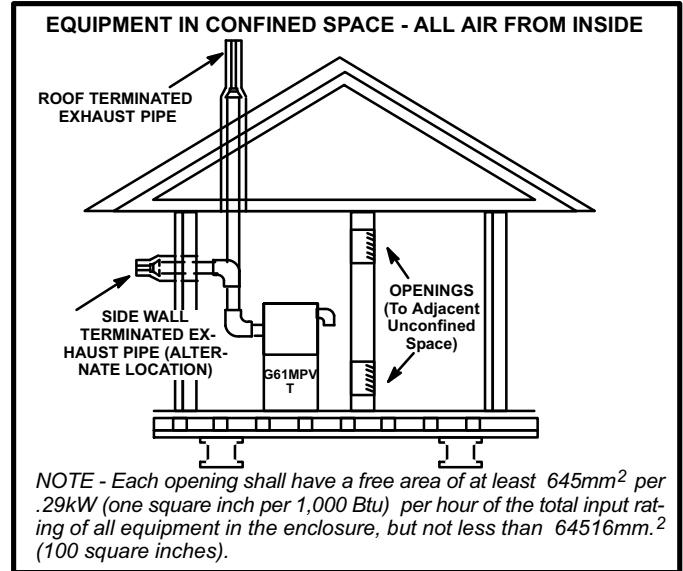

FIGURE 35

Air from Outside

If air from outside is brought in for combustion and ventilation, the confined space shall be provided with two permanent openings. One opening shall be within 305mm (12 inches) of the top of the enclosure and one within 305mm (12 inches) of the bottom. These openings must communicate directly or by ducts with the outdoors or spaces (crawl or attic) that freely communicate with the outdoors or indirectly through vertical ducts. Each opening shall have a minimum free area of 645mm² per 1.17kW (1 square inch per 4,000 Btu) per hour of total input rating of all equipment in the enclosure. When communicating with the outdoors through horizontal ducts, each opening shall have a minimum free area of 645mm² per .59kW (1 square inch per 2,000 Btu) per total input rating of all equipment in the enclosure.

When ducts are used, they shall be of the same cross-sectional area as the free area of the openings to which they connect. The minimum dimension of rectangular air ducts shall be no less than 75mm (3 inches). In calculating free area, the blocking effect of louvers, grilles, or screens must be considered. If the design and free area of protective covering is not known for calculating the size opening required, it may be assumed that wood louvers will have 20 to 25 percent free area and metal louvers and grilles will have 60 to 75 percent free area. Louvers and grilles must be fixed in the open position or interlocked with the equipment so that they are opened automatically during equipment operation.

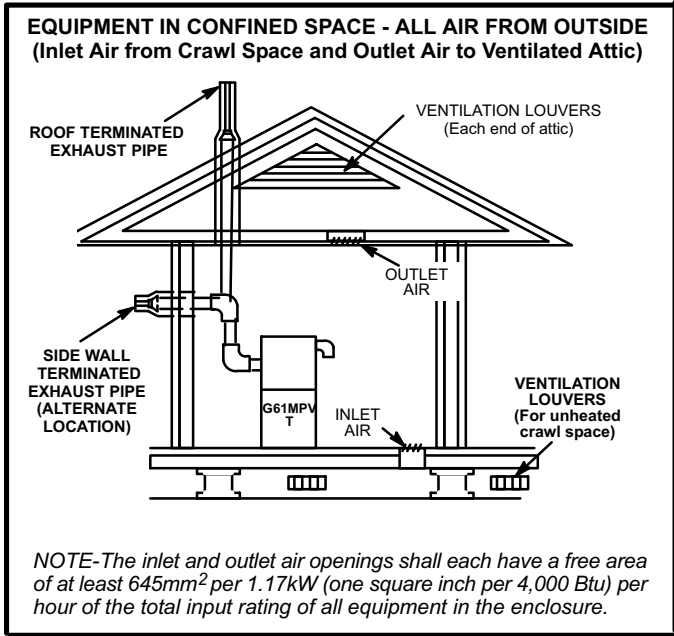

FIGURE 36

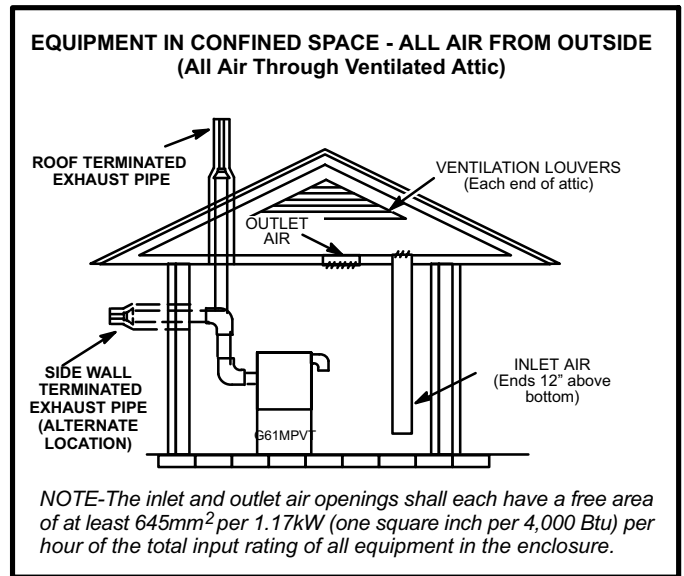

FIGURE 37

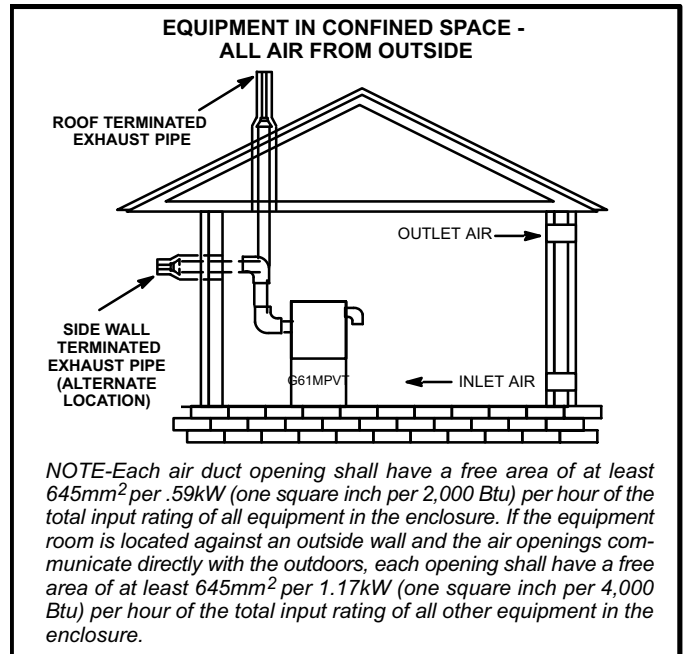

FIGURE 38

Ignition Control Board Diagnostic Codes (Red LED)

FLASH CODE (X + Y)	STATUS / ERROR DESCRIPTION
FLASH CODE DESCRIPTIONS	
Pulse	A 1/4 second flash followed by four seconds of off time.
Heartbeat	Constant 1/2 second bright and 1/2 second dim cycles.
X + Y	LED flashes X times at 2Hz, remains off for two seconds, flashes Y times at 2Hz, remains off for four seconds, then repeats.
Pulse	Power on - Standby.
Heartbeat	Normal operation - signaled when heating demand initiated at thermostat.
FLAME CODES	
1 + 2	Low flame current -- run mode.
1 + 3	Flame sensed out of sequence -- flame still present.
PRESSURE SWITCH CODES	
2 + 3	Low pressure switch failed open.
2 + 4	Low pressure switch failed closed.
2 + 5	High pressure switch failed open.
2 + 6	High pressure switch failed closed.
2 + 7	Low pressure switch opened during ignition trial or heating demand.
LIMIT CODE	
3 + 1	Limit switch open.
WATCHGUARD CODES	
4 + 1	Watchguard -- Exceeded maximum number of retries.
4 + 2	Watchguard -- Exceeded maximum number of retries or last retry was due to pressure switch opening.
4 + 3	Watchguard -- Exceeded maximum number of retries or last retry was due to flame failure.
4 + 5	Watchguard -- Limit remained open longer than three minutes.
4 + 6	Watchguard -- Flame sensed out of sequence; flame signal gone.
4 + 7	Ignitor circuit fault -- Failed ignitor or triggering circuitry.
4 + 8	Low line voltage.
HARD LOCKOUT CODES	
5 + 1	Hard lockout -- Rollout circuit open or previously opened.
5 + 2	Control failed self check, internal error (control will restart if error recovers).
5 + 3	No Earth ground (control will restart if error recovers).
5 + 4	Reversed line voltage polarity (control will restart if the error recovers).
5 + 6	Low secondary (24VAC) voltage.

Troubleshooting: Heating Sequence of Operation

HEATING SEQUENCE OF OPERATION NORMAL AND ABNORMAL HEATING MODE

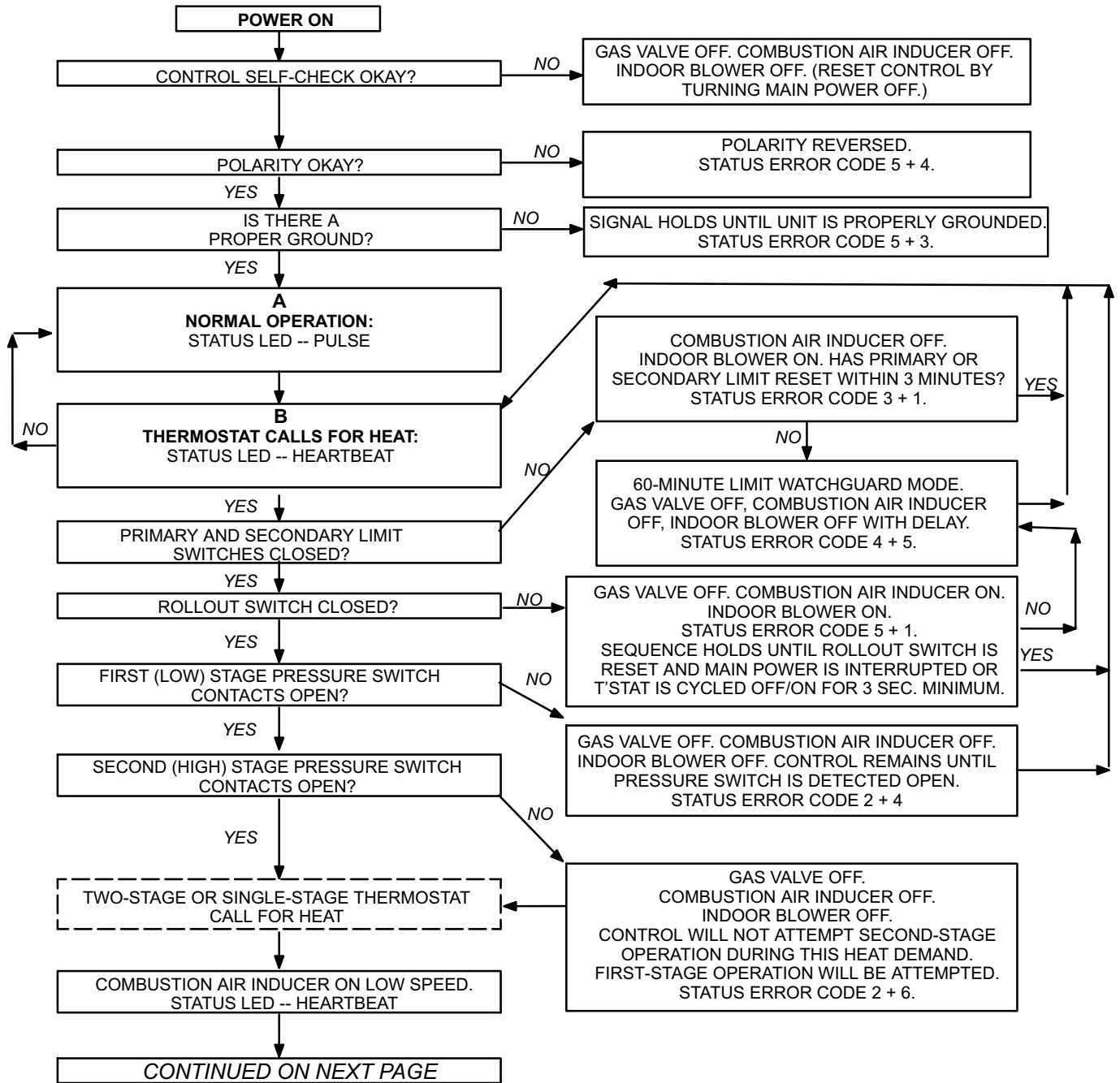

Troubleshooting: Heating Sequence of Operation (Continued)

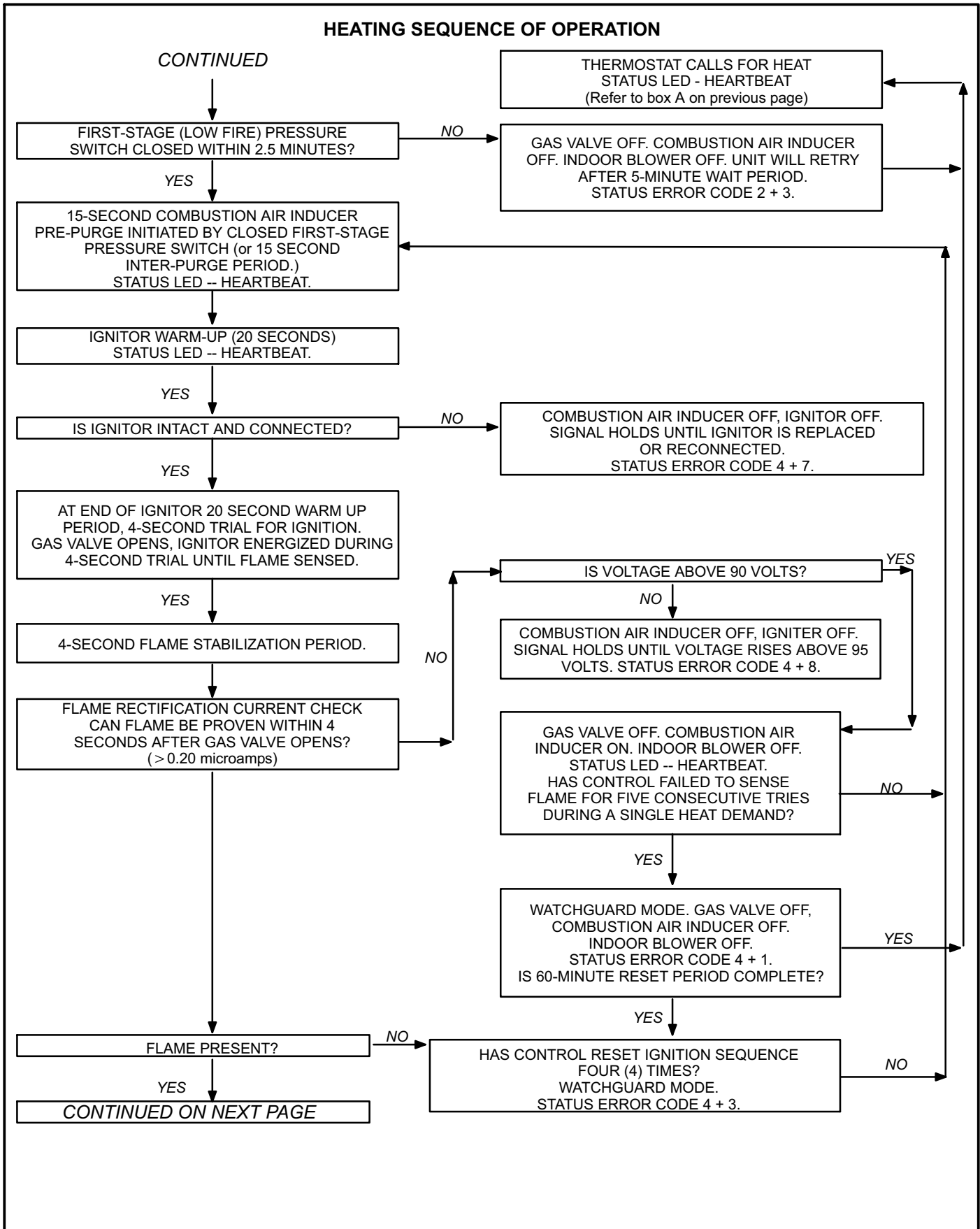

Troubleshooting: Heating Sequence of Operation (Continued)

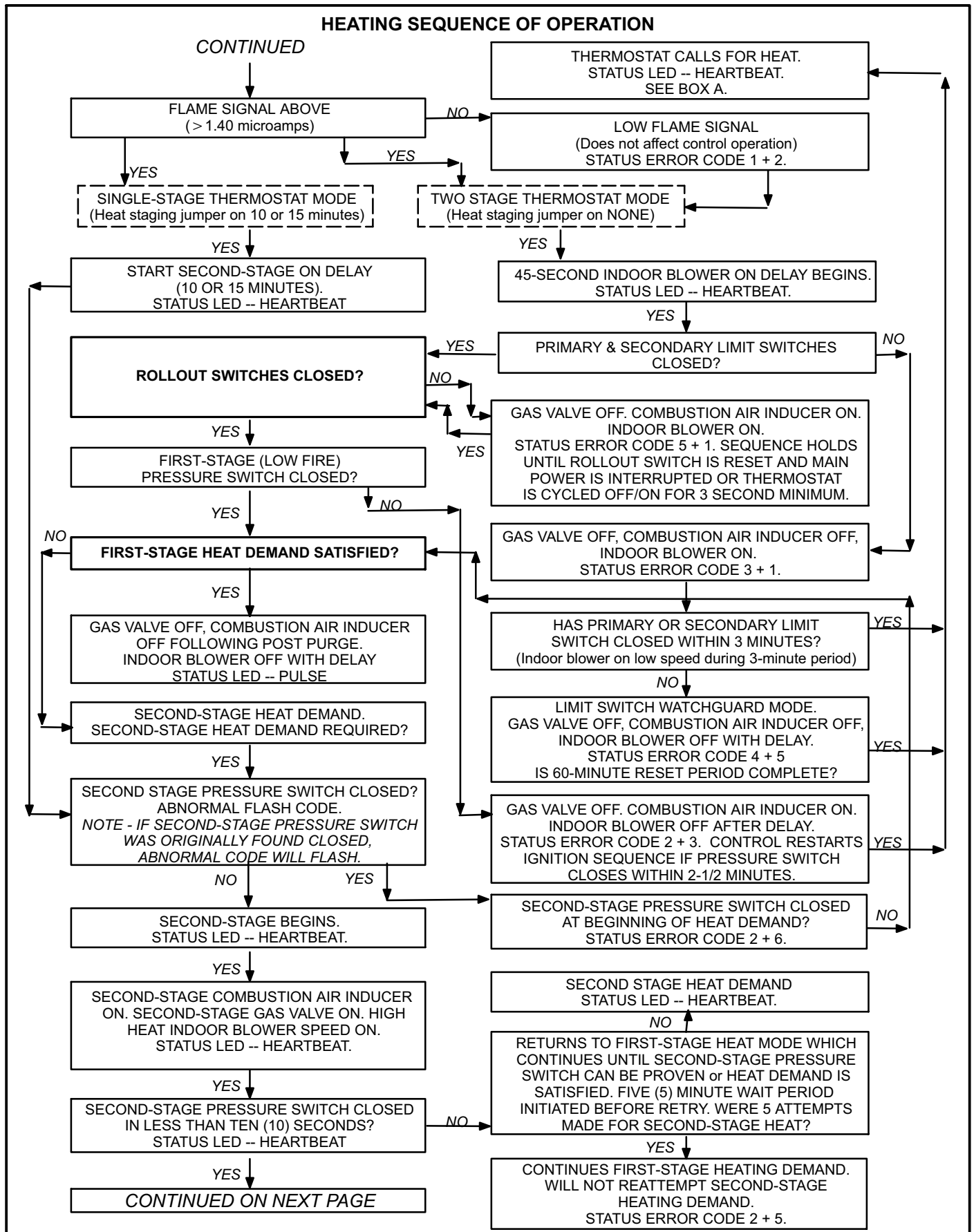

Troubleshooting: Heating Sequence of Operation (Continued)

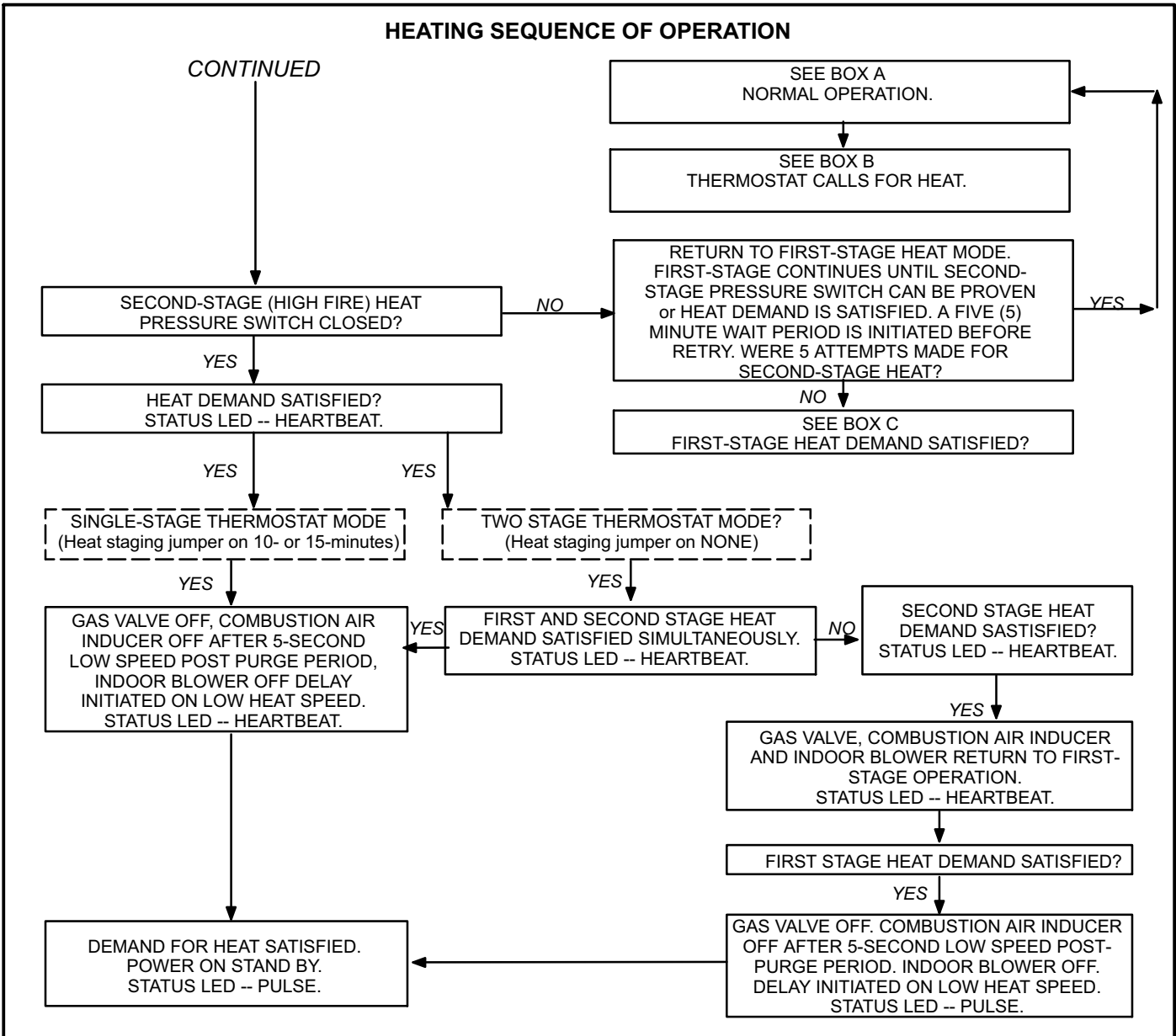

Troubleshooting: Cooling Sequence of Operation

COOLING SEQUENCE OF OPERATION

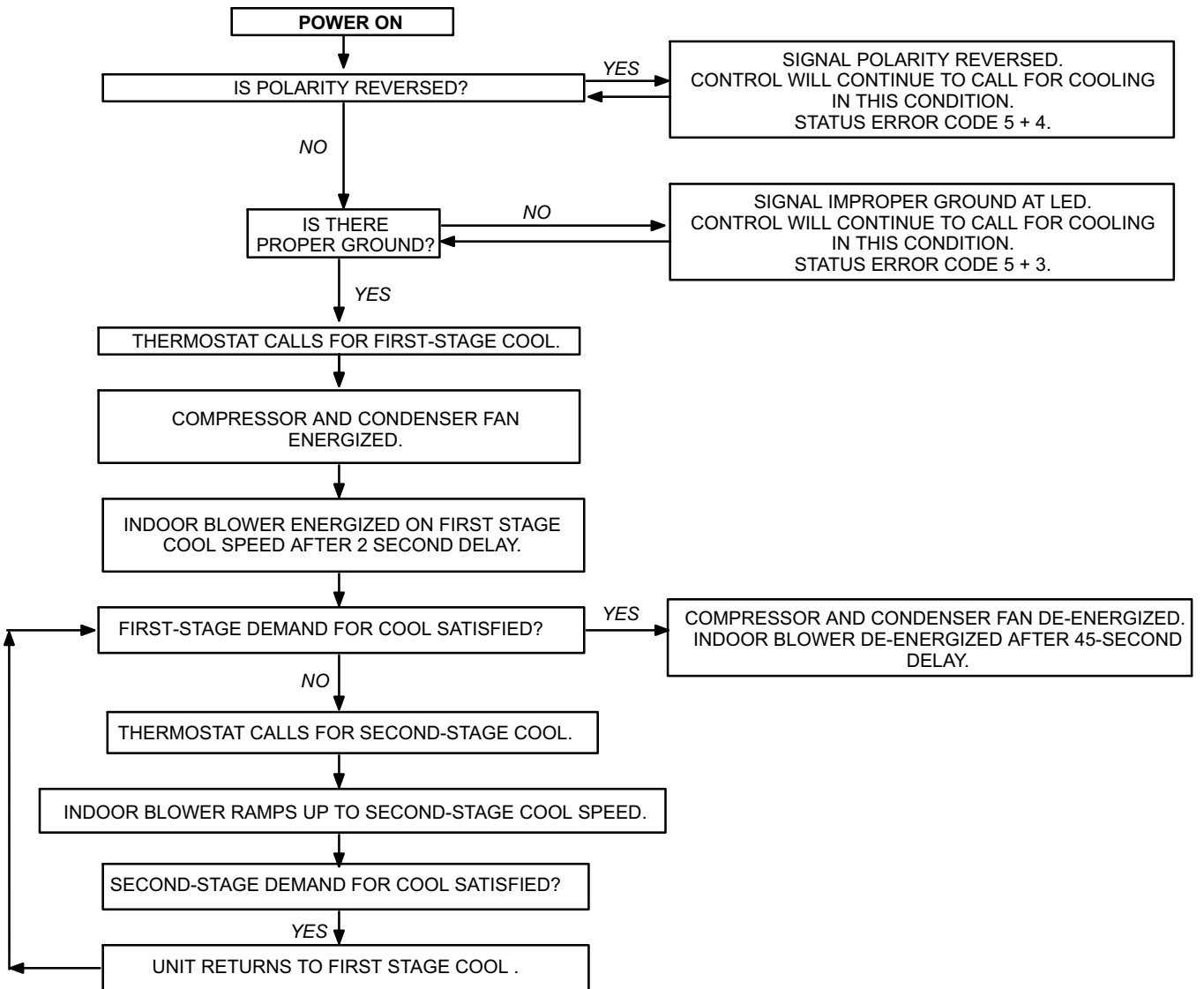

Troubleshooting: Continuous Fan Sequence of Operation

CONTINUOUS LOW SPEED FAN SEQUENCE OF OPERATION

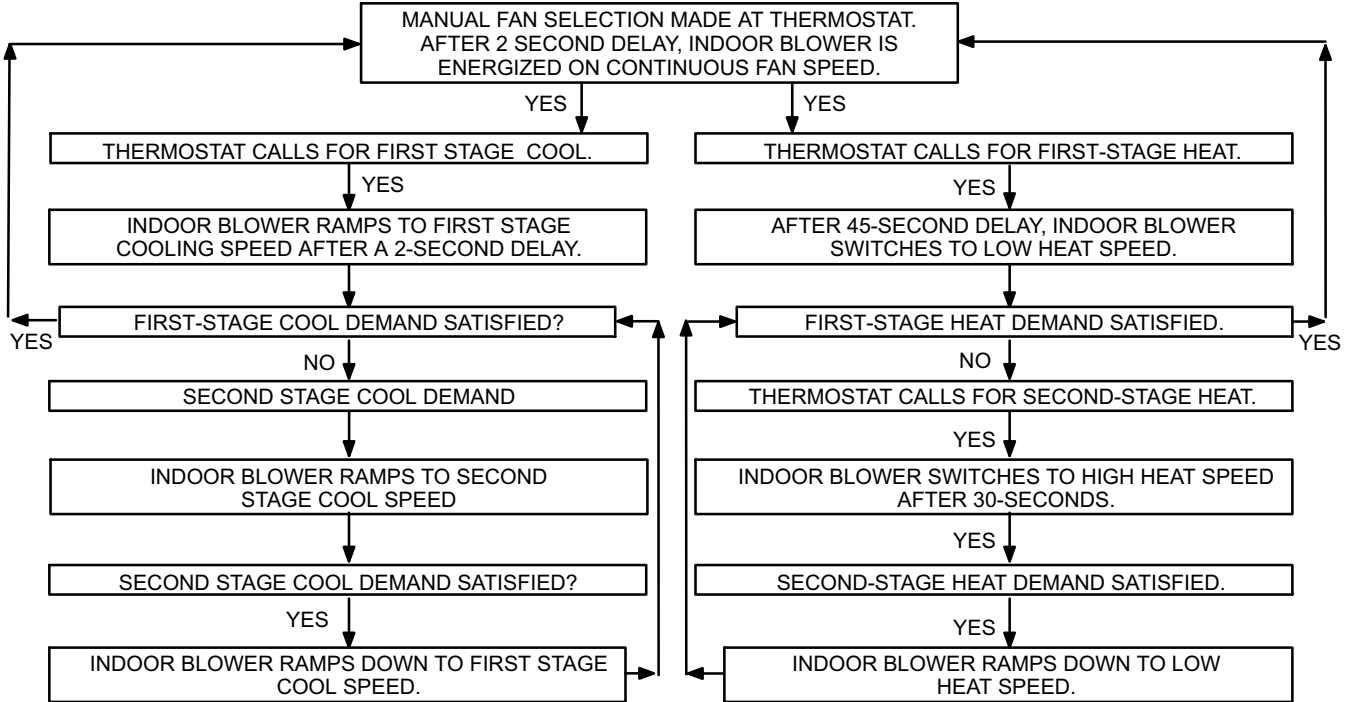

Repair Parts List

The following repair parts are available through Lennox dealers. When ordering parts, include the complete furnace model number listed on the nameplate -- Example: G61MPVT-36B-070-01.

Cabinet Parts

- Upper access panel
- Blower access panel
- Top Cap

Control Panel Parts

- Transformer
- Integrated control board
- Door interlock switch
- Circuit Breaker

Blower Parts

- Blower wheel
- Motor
- Motor mounting frame
- Blower housing cutoff plate

Heating Parts

- Flame Sensor
- Heat exchanger assembly
- Gas manifold
- Combustion air inducer
- Gas valve
- Main burner cluster
- Main burner orifices
- Pressure switches
- Ignitor
- Primary limit control
- Secondary limit control
- Flame rollout switches
- Combustion air inducer auxiliary limit

Vent Pipe Sizing Worksheet

Step 1	Proposed vent pipe size : _____	Equivalent Meters
Step 2	Termination kit catalog number : _____ Vent pipe equivalency value from table 6 : _____	
Step 3	Total number of 90° elbows required (indoors and outdoors) _____ X 1.5 = _____ equivalent meters of pipe	
Step 4	Total number of 45° elbows required (indoors and outdoors) _____ X .76 = _____ equivalent meters of pipe	
Step 5	Linear feet of straight pipe required : _____	
Step 6	Add equivalent meters of vent pipe listed in steps 2 through 5.	TOTAL

If the total is equal to, or less than, the allowable maximum given in table 6, the proposed pipe size is acceptable. If the total exceeds the maximum allowed vent pipe length, repeat the process above using the next larger diameter pipe until an acceptable total is achieved.

NOTE - In Direct Vent systems, total the equivalent length of either the exhaust OR intake piping run, depending upon which will be LONGER. Intake and exhaust pipe diameter must be the same size and must be terminated in the same pressure zone. Intake and exhaust pipe should be roughly the same length.

G61MPVT Start-Up & Performance Check List

Job Name _____ Job No. _____ Date _____
Job Location _____ City _____ State _____
Installer _____ City _____ State _____
Unit Model No. _____ Technician _____
Serial No. _____

Heating Section

Electrical Connections Tight?
Supply Voltage _____ Blower Motor H.P. _____
Blower Motor Amps Gas Piping Connections
Tight & Leak-Tested?
Fuel Type: Natural Gas? LP/Propane Gas?
Furnace Btu Input _____
Line Pressure _____
Regulator Pressure _____ w.c. - Nat.: _____ w.c. - LP/Propane
Flue Connections Tight? Proper Draft?
Condensate Connections Tight?
Combustion Gas Tested? CO₂ CO
Fan Control Setting
(45 Seconds Fixed On) _____
Fan Control Off Setting _____ Temperature Rise _____
Filter Clean & Secure? Vent Clear?

Thermostat

Calibrated? Heat Anticipator Properly Set? Level?