



ENGINEERING DATA

GAS FURNACES

G61MPVT

Multi-Position - Two-Stage Heat
Variable-Speed - 50HZ

Bulletin No. 490115

April 2007

Supersedes January 2007



Australian Gas Association Rating - 5.3 Stars
Input - 69.6 to 139.3 Mj/h
Nominal Add-on Cooling - 10.5 to 17.6 kW

MODEL NUMBER IDENTIFICATION

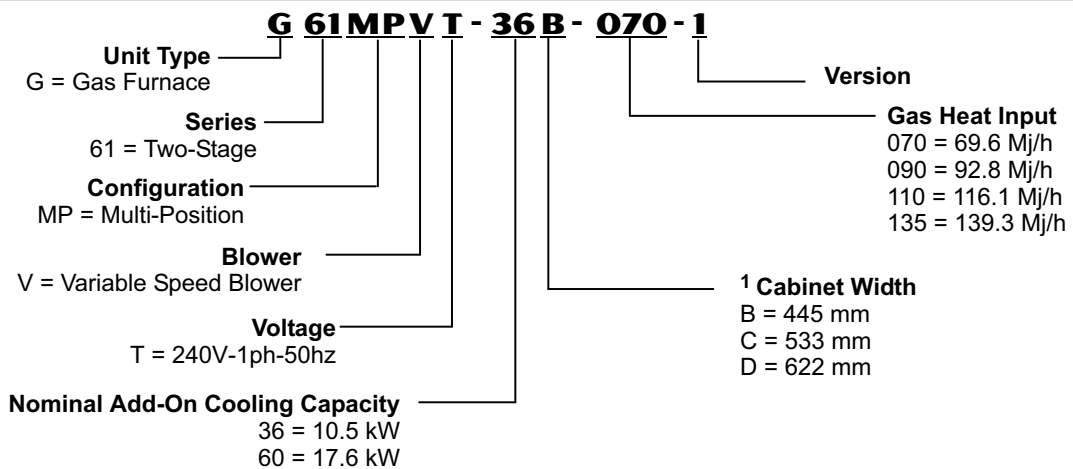

¹ Indoor coils with the same letter designation will physically match the furnace.

FEATURES

CONTENTS

Blower Data	Pages 12-13
Dimensions	Pages 8-11
Exhaust Pipe Venting Information	Page 6
Features and Options	Pages 2-4
Filter Air Resistance	Page 7
Installation Clearances	Page 7
Model Number Identification	Page 1
Optional Accessories Selection Table	Page 5
Specifications	Page 5
Revisions	Page 14

WARRANTY

Duralok Plus® Aluminized Steel Heat Exchanger - Ten year limited warranty in residential applications, five year limited warranty in non-residential applications.

All other covered components - Five years limited warranty in residential applications, two year limited warranty in non-residential applications.

Refer to Lennox Equipment Limited Warranty certificate included with equipment for details.

APPROVALS

Australian Gas Association approval.

Blower data from unit tests conducted in Lennox Laboratory air test chamber.

ENERGY STAR® (US Department of Energy) certified units are designed to use less energy, help save money on utility bills, and help protect the environment
ISO 9001 Registered Manufacturing Quality System.

APPLICATIONS

Input capacities of 69.6, 92.8, 116.1 and 139.3 Mj/h

Australian Gas Association Rating - 5.3 Stars

Compact cabinet for up-flow, down-flow, horizontal-left or horizontal-right applications without any internal modifications to the unit.

G61MPVT-60D-135 can only be installed in horizontal-right or down-flow applications.

Lennox add-on indoor coils, high-efficiency air cleaners and humidifiers can easily be added to furnace.

Shipped factory assembled with all controls installed and wired.

Each unit factory test operated to ensure proper operation.

DIRECT VENT / NON-DIRECT VENT

Furnace can be installed in either Direct Vent or Non-Direct applications. G61MPVT-60D-135 can only be installed in direct vent applications.

In Direct Vent applications, combustion air is supplied from outdoors and flue gases are discharged outdoors. In Non-Direct Vent applications, combustion air is supplied from indoors and flue gases are discharged outdoors.

OPTIONS

Termination Kits

Facilitates installation of combustion air intake pipe and flue exhaust pipe.

Refer to venting table in this bulletin to determine pipe size needed and proper termination kit required.

See Specifications table and dimension drawings.

Termination Kit - Concentric - Direct Vent

Applications Only

50 or 80 mm (2 or 3 inch) kit contains concentric termination assembly, reducer bushing and 45 degree elbow.

50 mm (2 inch) kit for -070 models contains an exhaust accelerator.

Kit requires single hole penetration of roof or wall for installation.

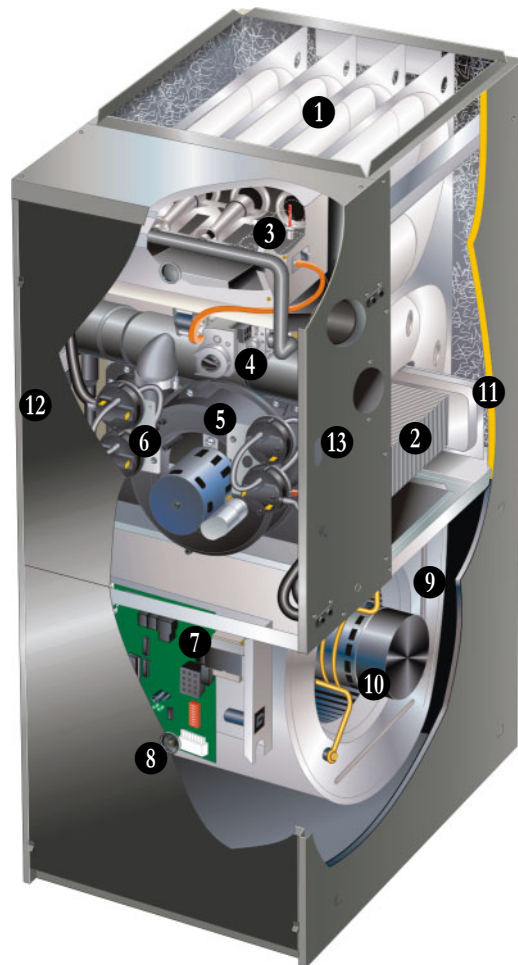

HEATING SYSTEM

- 1 Lennox Duralok Plus® Heat Exchanger Assembly**
Lennox developed heat exchanger assembly consists of primary heat exchanger and secondary condenser coil assembly.
Main 3-pass clamshell type heat exchanger constructed of heavy-gauge, aluminized steel.
Designed for normal expansion and contraction.
Crimped seam design and construction provides maximum efficiency and minimum resistance to airflow.
- 2 Secondary heat exchanger condenser coil constructed of aluminum fins fitted to stainless steel tubes.**
Coil is factory tested for leaks.
Condensate drain header box assembly located on front of coil.
Compact size of complete heat exchanger assembly permits low overall design of furnace cabinet.
All components mounted in a heavy-gauge steel frame.
Heat exchanger assembly has been laboratory life cycle tested.

Lennox Designed Header Box

Header box on end of condenser coil collects flue condensate for disposal through condensate collars. Hose connects the header box drains to the condensate collars.

The condensate collars are located on each side of the cabinet for easy field installation of condensate drain trap. Only one collar is used, the remainder stay plugged.

Condensate drain trap is included with the unit for field installation.

FEATURES

HEATING SYSTEM - CONTINUED

Lennox Designed Flue Condensate Trap Assembly
Condensate trap assembly is mounted outside the conditioned air stream.

Assembly can be mounted on either side of cabinet in up-flow and down-flow applications. Assembly is mounted on the bottom of the cabinet in horizontal applications. See Installation Instructions.

Connection can be made with field provided 1/2 in. PVC pipe, 3/4 in. PVC coupling, or 1-1/4 in. OD x 1 in. ID tubing with hose clamp.

Easy to clean and winterize.

3 Inshot Burners

Aluminized steel inshot burners provide efficient, trouble-free operation.

Burner venturi mixes air and gas in correct proportion for proper combustion.

Burner assembly is removable from the unit as a single component for ease of service.

4 Two-Stage Gas Control Valve

24 volt redundant combination two stage gas control valve combines manual shut off valve (On-Off), automatic electric valve (dual) and gas pressure regulation into a compact combination control.

Flame Rollout Switch

Manual reset switches are factory installed on burner box.

Switch provides protection from abnormal operating conditions.

Hot Surface Mini-Nitride Ignitor

Unique, non-porous, high strength proprietary ceramic material provides long life and trouble-free maintenance.

Low mass element provides fast heat-up and consistent igniter temperature with low power usage.

Cemented to alumina block for positive mounting and protection against current leakage.

High temperature Teflon® insulated ignition lead wires for dependable operation.

5 Combustion Air Inducer

PSC, heavy-duty blower prepurges heat exchanger and safely vents flue products.

6 Pressure switches prove blower operation before allowing gas valve to open.

Operates only during heating cycle.

Limit Control

Automatic reset, primary and secondary limits are accurately located.

Primary limit factory installed on vestibule panel on all units, secondary limit factory installed on blower housing.

OPTIONS

High Altitude Pressure Switch Kit

Required on certain units for proper unit operation on installations above 610 m.

Units not approved for installations above 1372 m.

Order two per unit.

LPG/Propane Conversion Kit

Required for field changeover from natural gas to LPG/Propane.

Natural Gas Conversion Kit

Required for field changeover from LPG/Propane to natural gas.

CONTROLS

7 Integrated Two Stage / Variable Speed Blower Control

Solid-state board contains all necessary controls and relays to operate furnace.

Combustion air inducer is controlled by board. Prior to ignition, a pre-purge cycle for 15 seconds is initiated. After the main burners are turned off, a post-purge cycle for 5 seconds is run.

Electronic flame sensor assures safe, reliable operation.

Should flame fail to ignite, flame sensor will initiate 4 re-attempts at ignition before locking out unit operation for 60 minutes.

Watchguard type circuit automatically resets ignition controls after one hour of continuous thermostat demand after unit lockout, eliminating nuisance calls for service.

To aid in troubleshooting, the last three fault codes are stored for a maximum of six months. Displays the fault codes through indicator LED's.

Jumper settings for 1 or 2 stage thermostat operation. Two selectable 2nd stage recognition times (10 and 15 minutes) are available on the board when the furnace is used with a single stage thermostat. When used with a two stage thermostat, furnace will only initiate second stage operation with a second stage thermostat demand.

8 Two accessory terminals furnished for additional power supply requirements for 240 volt (less than 1 amp) power humidifiers and powered air cleaners.

Two blower speeds - second stage heat and second stage cool (with four air volume selections for each) are selected by DIP switches on board. Heat speed can be adjusted to optimize discharge temperature. Cool speed can be adjusted to correct optional cooling capacity. See Blower Performance tables.

First stage blower speed is a percentage of 2nd stage speed.

The ADJUST switch (DIP) allows normal (NORM), 10% higher (+ plus) or 10% lower (— minus) motor speed selection within HEAT and COOL speeds selected for fine tuning air volume.

DELAY switch (DIP) allows one of four de-humidification profiles during cooling mode.

Profile A - Motor runs at 50% for 30 seconds, then at 82% for 7-1/2 minutes, then at 100% (if needed) until demand is satisfied. Once demand is met, motor runs at 50% for 30 seconds, then ramps down to stop.

Profile B - Motor runs at 82% for 7-1/2 minutes and then at 100% (if needed) until demand is satisfied. Once demand is met, motor ramps down to stop.

Profile C - Motor runs at 100% until demand is satisfied. Once demand is met, motor runs at 100% for 60 seconds, then ramps down to stop.

Profile D - Motor runs at 100% until demand is satisfied. Once demand is met, motor ramps down to stop.

In heat mode, blower on time is fixed at 45 seconds, blower off time is adjustable from 60, 90, 120 and 180 seconds (factory setting - 90 seconds).

Power Lead

2.5 m power lead is provided for connection to an IEC receptacle located on the right side of the furnace.

IEC Receptacle

IEC receptacle provided on right side of furnace cabinet for easy, plug-in electrical connection.

24 Volt Transformer

Furnished and factory installed on blower wrapper.

40VA transformer has circuit breaker wired in series.

FEATURES

CONTROLS - CONTINUED

OPTIONS

SignatureStat™ Home Comfort Control

Combination temperature and humidity.

2 Heat/2

Cool

Auto-changeover

Controls humidity during cooling operation.

Easy-to-use, menu

driven thermostat with a back-lit, dot-matrix LCD screen.

Remote outdoor sensor (furnished) allows the thermostat to display outdoor temperature and adjust indoor dewpoint temperature for precision humidity control in cooling mode.

See the SignatureStat Engineering Handbook bulletin in the Controls section for more information.



BLOWER

9 Variable Speed Direct Drive Blower

Each blower assembly statically and dynamically balanced.

Change in blower speed is easily accomplished by simple DIP switch change on Integrated Furnace Two Stage / Variable Speed Blower Control.

See Blower Performance tables.

Blower assembly easily removed for servicing

10 Variable Speed Blower Motor

Variable speed motor maintains specified air volume from 0 through 200 Pa static range.

Motor is controlled by Integrated Furnace Two Stage / Variable Speed Blower Control.

Motor is resiliently mounted.

FILTER (NOT FURNISHED)

Filter and provisions for external mounting must be field provided.

CABINET

Low-profile, narrow width cabinet allows easy installation in up-flow, down-flow or horizontal applications.

Heavy-gauge, cold rolled steel construction.

Pre-painted cabinet finish.

Flanges provided on supply air opening for ease of plenum connection or alignment with indoor coil.

11 Fully insulated cabinet with foil faced insulation on sides and back of heating compartment and mat faced insulation in blower compartment.

12 Tool-less latches on blower and burner doors assure positive lock.

Complete service access.

Safety interlock switch automatically shuts off power to unit when blower compartment access door is removed.

13 Gas piping inlets are provided in both sides of cabinet.

Return Air Entry:

For bottom/end return-air entry for up-flow/horizontal applications, remove furnished bottom seal panel from cabinet.

For side return-air entry (up-flow applications only), corners are marked on either side of cabinet for return air cut-outs.

On furnaces with side return air and condensate trap on the same side of the cabinet, a field fabricated transition is required when using an IAQ (indoor air quality) product higher than 360 mm installed next to the unit and serviced from the front. IAQ products higher than 508 mm require a field fabricated transition. See dimension drawings.

NOTE - 60C and 60D size units that require air volumes over 850 L/s must have one of the following:

1. Single side return air with transition, to accommodate 508 x 635 x 25 mm cleanable air filter, required to maintain proper air velocity.
2. Bottom return air.
3. Return air from both sides.
4. Bottom and one side return air.

See Blower Performance Tables for additional information.

Coil Match-up

All furnaces exactly match C33 and CX34 cased up-flow indoor coils and CH33 horizontal indoor coils with same letter designation in model number. No adaptor required. Engaging holes furnished on cabinet for alignment.

C33 uncased coils match furnaces without any overhang but require an optional adaptor base or field fabricated transition to match furnace opening. See C33 coil bulletin for additional information.

All furnaces exactly match CR33 cased, down-flow indoor coils with adaptor rails, furnished with coil.

OPTIONS

Condensate Trap Alternate Location Kit

Allows condensate drain to be installed on the opposite side of the furnace from the exhaust venting (up-flow applications only).

Down-Flow Combustible Floor Base

Required for heating only units installed on combustible floors.

Not required in add-on cooling applications.

See Dimension Drawing.

SPECIFICATIONS

Gas Heating Performance		Model No.	G61MPVT-36B-070	G61MPVT-60C-090	G61MPVT-60C-110	G61MPVT-60D-135
High Fire	Input - Mj/h		69.6	92.8	116.1	139.3
	Output - kW		17.9	23.7	29.0	35.7
	Temperature rise range - °C		25 - 41	22 - 39	28 - 44	36 - 53
	Gas Manifold Pressure (Natural Gas) - Pa		0.87	0.87	0.87	0.87
Low Fire	Input - Mj/h		47.5	63.3	79.1	95.0
	Output - kW		12.6	16.7	21.1	25.5
	Temperature rise range - °C		14 - 31	11 - 28	17 - 33	22 - 39
	Gas Manifold Pressure (Natural Gas) - kPa		0.42	0.42	0.42	0.42
Australian Gas Association Energy Rating - Stars			5.3	5.3	5.3	5.3
High static - Pa			200	200	200	200
Connections in.	Intake / Exhaust Pipe (PVC)		2 / 2	2 / 2	2 / 2	3 / 3
	Condensate Drain Trap (PVC pipe) - i.d.		1/2	1/2	1/2	1/2
	with field supplied (PVC cplg.) - o.d.		3/4	3/4	3/4	3/4
	hose with hose clamp - i.d. x o.d.		1-1/4 x 1	1-1/4 x 1	1-1/4 x 1	1-1/4 x 1
	Gas pipe size IPS		1/2	1/2	1/2	1/2
Indoor Blower	Wheel nom. dia. x width - mm		254 x 203	292 x 254	292 x 254	292 x 254
	Motor output - W		373	745	745	745
	kW of add-on cooling		7.0 - 12.2	12.2 - 17.6	12.2 - 17.6	12.2 - 17.6
	Air Volume Range - L/s		295 - 660	410 - 1020	350 - 1045	430 - 1035
Shipping Data	kg - 1 package		68	82	85	94
Electrical characteristics			240 volts - 50 hertz - 1 phase (less than 10 amps)			

NOTE - Filters and provisions for mounting are not furnished and must be field provided.

OPTIONAL ACCESSORIES - MUST BE ORDERED EXTRA

	"B" Width Models	"C" Width Models	"D" Width Models
CABINET ACCESSORIES			
Down-Flow Combustible Floor Base	11M60	11M61	11M62
CONDENSATE DRAIN KITS			
Condensate Trap Alternate Location Kit - Up-Flow Only	76M20	76M20	---
CONTROLS			
TERMINATION KITS - See Installation Instructions for specific venting information.			
Concentric Termination Kits - Direct Vent Applications Only	50 mm (2 in.) 80 mm (3 in.)	71M80 ---	69M29 60L46

			60L46

GAS HEAT ACCESSORIES

Input	High Altitude Pressure Switch Kit ORDER TWO EACH 611 - 1372 m	LPG/Propane Kit		LPG/Propane to Natural Gas Kit	
		0 - 610 m	611 - 1372 m	0 - 610 m	611-1372 m
-070	56M23	59M13	59M13	59M87	59M87
-090	56M23	59M13	59M13	59M87	59M87
-110	75M22	59M13	59M13	59M87	59M87
-135	Not allowed	59M13	Not allowed	59M87	Not allowed

HIGH ALTITUDE INFORMATION

Pressure regulator adjustment will be required depending on altitude. See below for proper pressure regulator setting.

Fuel	Manifold Pressure (Outlet) at High Fire - kPa Altitude - m			
	0-610	¹ 611-914	¹ 915-1219	¹ 1220-1372
Natural	0.87	0.80	0.75	0.70
² LPG/Propane	2.49	2.29	2.12	2.02

¹ High Altitude Pressure Switch Kits required for certain models, see Gas Heat Accessories table for order number.

² LPG/Propane conversion kit required, see Gas Heat Accessories table for order number.

EXHAUST PIPE VENTING TABLE

Vent Pipe Diameter	For altitudes of 0-610 m ¹ Maximum Equivalent Vent Length - m				For altitudes of 611-1372 m ¹ Maximum Equivalent Vent Length - m			
	G61MPVT -36B-070	G61MPVT -60C-090	² G61MPVT -60C-110	³ G61MPVT -60D-135	G61MPVT -36B-070	G61MPVT -60C-090	² G61MPVT -60C-110	³ G61MPVT -60D-135
50 mm (2 in.)	12.2	4.5	not allowed	not allowed	7.6	not allowed	not allowed	not allowed
80 mm (3 in.)	16.1	12.2	12.2	7.6	10	7.6	7.6	not allowed
100 mm (4 in.)	44	34.5	30	20	27.5	21.5	18.7	not allowed

NOTE - Minimum Equivalent Vent Pipe length is 4.6 m.

¹ Maximum Equivalent Vent Length¹ permitted is defined as "Total Length (linear meters) of vent pipe, plus equivalent length (m) of fittings, plus equivalent length (m) of termination".

² 110 models installed in up-flow or down-flow applications must have the supplied 90° street ell installed directly into the unit flue collar. The street ell must be included in the elbow count.

³ 135 models installed in down-flow applications must have 80 to 50 mm (3 in. to 2 in.) reducing elbow (supplied) installed directly into the flue collar. Reducing ell must be included in elbow count.

⁴ 90° elbows must be limited to sweep type elbows.

VENTING NOTES — One 90° elbow is equivalent to 1.5 m of straight vent pipe.

Two 45° elbows are equal to one 90° elbow.

One 45° elbow is equivalent to 0.76 m of straight vent pipe.

Wall and roof termination (non-concentric) exhaust pipe must terminate with reducer to improve exhaust velocity away from intake piping.

070 - 50, 80, or 100 mm (2, 3 or 4 in.) - terminate with 40 mm (1-1/2 in.) pipe

090 - 50, 80, or 100 mm (2, 3 or 4 in.) - terminate with 50 mm (2 in.) pipe

110 - 80 or 100 mm (3 or 4 in.) - terminate with 50 mm (2 in.) pipe

135 - 80 or 100 mm (3 or 4 in.) - terminate with 50 mm (2 in.) pipe

TERMINATION KITS - EQUIVALENT VENT LENGTHS

Heat Size	Vent Pipe Diameter	Vent Pipe Equivalent Length - meters			
		Concentric Kits		Outdoor Exhaust Accelerator (Diameter X Length)	
		50 mm (2 in.) ¹ 71M80 or 69M29	80 mm (3 in.) 60L46	40 mm (1-1/2 in.) x 305 mm	50 mm (2 in.) x 305 mm
-070	50 mm (2 in.)	3.6	not allowed	1.2	not allowed
	80 mm (3 in.)	7.3	not allowed	2.4	not allowed
	100 mm (4 in.)	12.8	not allowed	4.3	not allowed
-090	50 mm (2 in.)	0.9	0.9	not allowed	0.3
	80 mm (3 in.)	1.8	1.8	not allowed	0.6
	100 mm (4 in.)	3.7	3.7	not allowed	1.2
-110	80 mm (3 in.)	1.8	1.8	not allowed	0.6
	100 mm (4 in.)	3.7	3.7	not allowed	1.2
-135	80 mm (3 in.)	not allowed	4.6	not allowed	1.8
	100 mm (4 in.)	not allowed	7.6	not allowed	3.0

¹ Outdoor exhaust accelerator included in 71M80 kit; for use with -070 models.

INSTALLATION CONFIGURATIONS

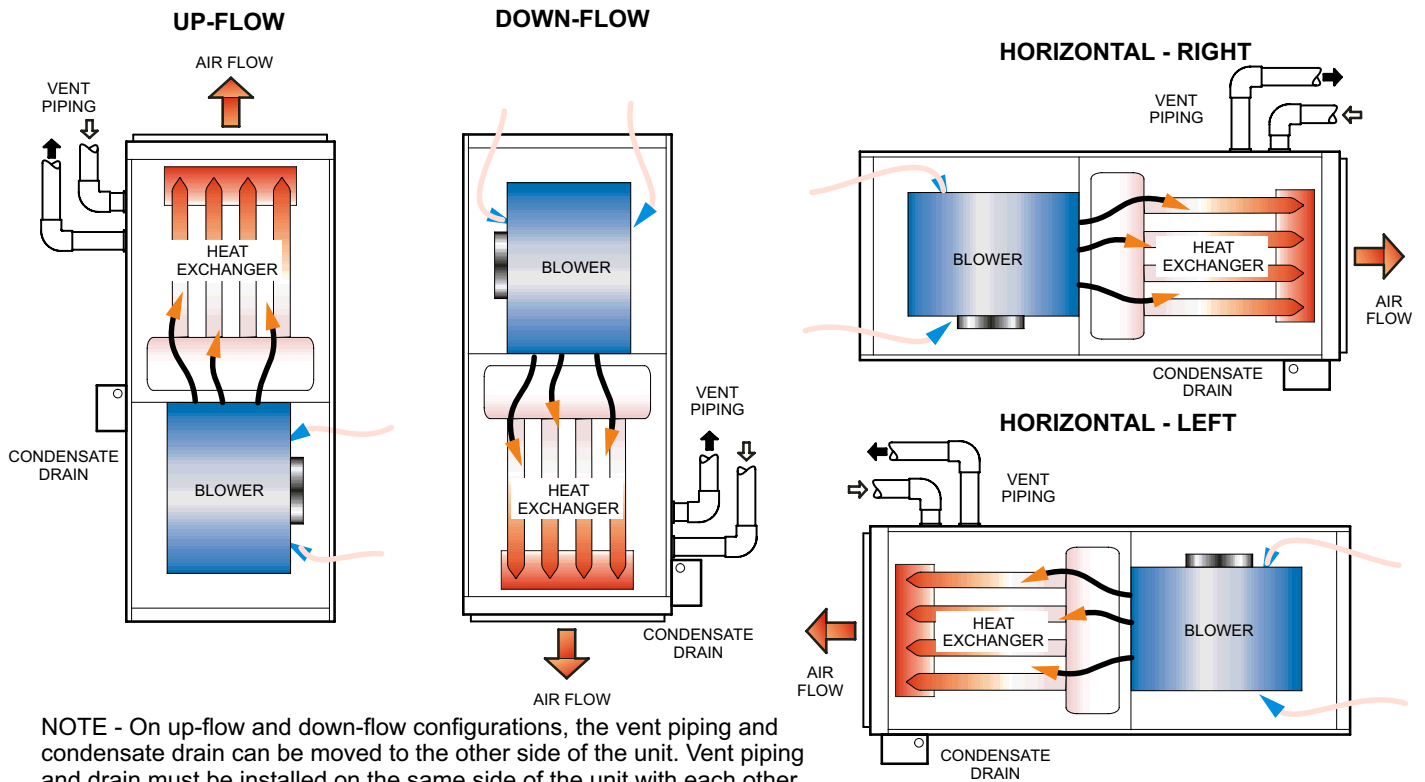

NOTE - On up-flow and down-flow configurations, the vent piping and condensate drain can be moved to the other side of the unit. Vent piping and drain must be installed on the same side of the unit with each other unless optional Condensate Trap Alternate Location Kit (up-flow only) is used. On horizontal installations the drain must be located at the bottom and the vent piping at the top.

FILTER AIR RESISTANCE

For 25 mm Cleanable Filter (Field Provided)

L/s	Pa
0	0
95	2
190	7
285	10
375	15
470	22
565	30
660	37
755	47
850	57
945	67
1040	82
1130	94
1225	109

INSTALLATION CLEARANCES

Sides	1 0 mm
Rear	0 mm
Top/Plenum	25 mm
Front	0 mm
Front (service/alcove)	610 mm
Floor	² Combustible

¹ Allow proper clearances to accommodate condensate trap and vent pipe installation.

² Clearance for installation on combustible floor if optional down-flow combustible floor base is installed between furnace and combustible floor. Not required in add-on cooling applications if installed in accordance with local codes Do not install the furnace directly on carpeting, tile, or other combustible materials other than wood flooring.

DIMENSIONS - MM - UP-FLOW POSITION SHOWN

¹ NOTE - 60C and 60D size units that require air volumes over 850 L/s must have one of the following:

- a. Single side return air with transition, to accommodate 508 x 635 x 25 mm air filter. Required to maintain proper air velocity.
- b. Bottom return air.
- c. Return air from both sides.
- d. Bottom and one side return air.

See Blower Performance Tables for additional information.

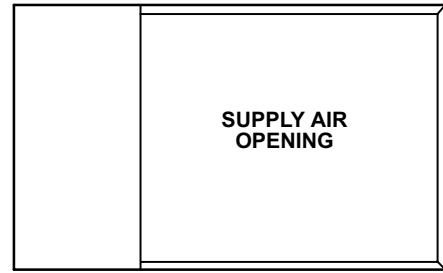

TOP VIEW

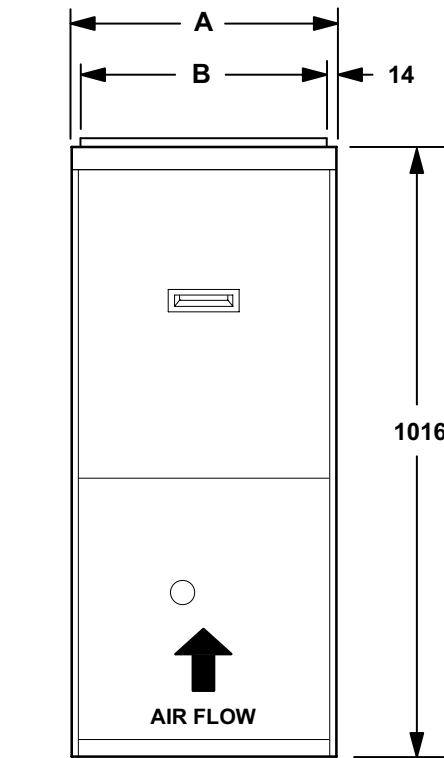

**¹ Bottom Return Air Opening
FRONT VIEW**

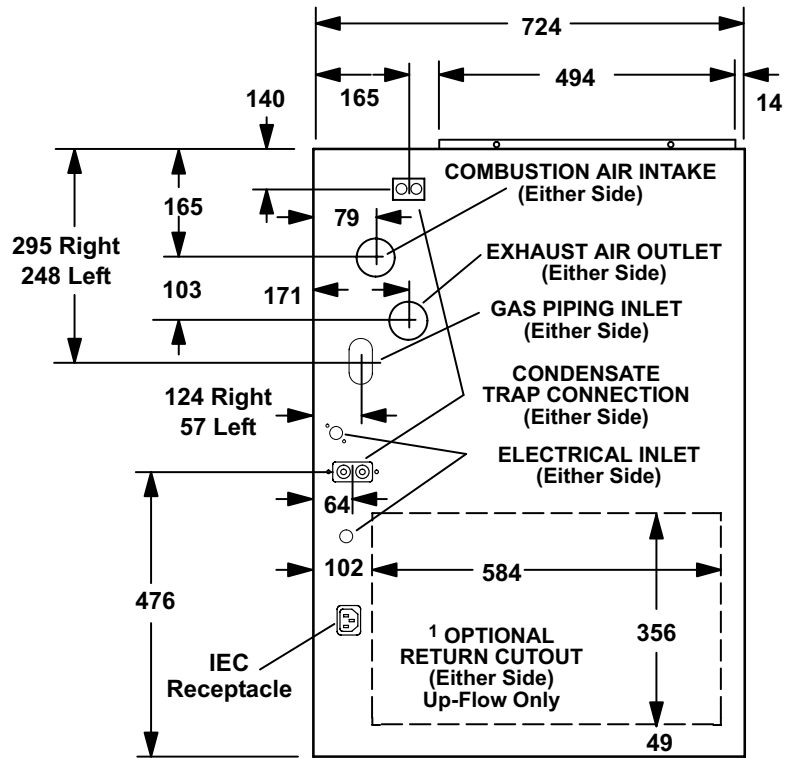

**¹ Bottom Return Air Opening
SIDE VIEW**

Model No.	A	B	C
G61MPVT-36B-070	446	416	406
G61MPVT-60C-090 G61MPVT-60C-110	533	505	495
G61MPVT-60D-135	622	594	584

DIMENSIONS - MM - FURNACE/COIL COMBINED DIMENSIONS

UP-FLOW POSITION

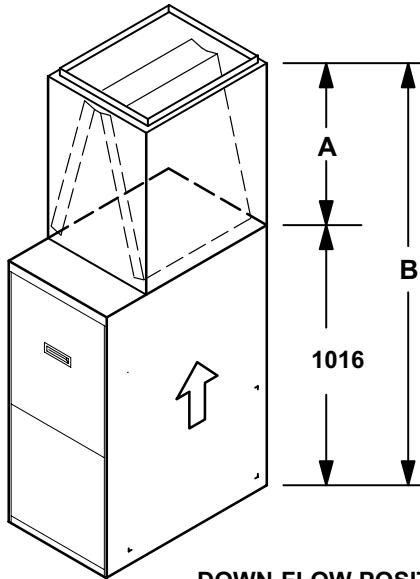

DOWN-FLOW POSITION

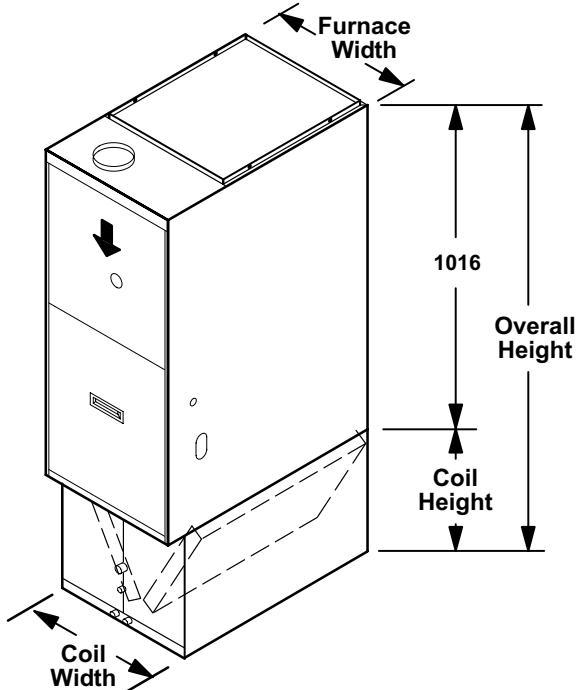

HORIZONTAL

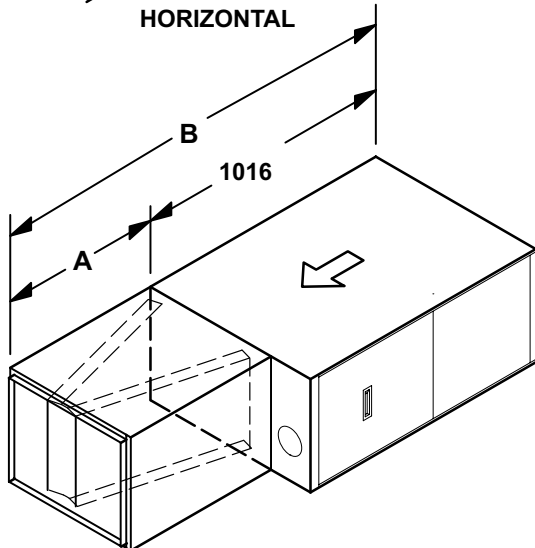

UP-FLOW POSITION

Model No		Cased		Uncased (CX34 - cased only)	
		A	B	A	B
CX34-18/24B-6F	C33-24B	419	1435	352	1368
CX34-18/24C-6F	C33-24C				
CX34-25B-6F	C33-25B	495	1511	403	1419
CX34-30B-6F	C33-30B	521	1537	451	1467
CX34-30C-6F	C33-30C				
CX34-31B-6F	C33-31B	597	1613	514	1530
CX34-36B-6F	C33-36B	622	1638	556	1572
CX34-36C-6F	C33-36C	622	1638	540	1556
CX34-38B-6F	C33-38B	622	1638	559	1575
CX34-42B-6F	C33-42B	622	1638	556	1572
CX34-43B-6F	C33-43B	724	1740	667	1683
CX34-43C-6F	C33-43C	724	1740	654	1670
	C33-44C	622	1638	546	1562
CX34-44/48B-6F	C33-48B	622	1638	562	1578
CX34-44/48C-6F	C33-48C	622	1638	546	1562
CX34-49C-6F	C33-49C	749	1765	724	1740
CX34-50/60C-6F	C33-50/60C	699	1715	629	1645
CX34-60D-6F	C33-60D	648	1664	629	1645
CX34-62C-6F	C33-62C	749	1765	778	1793
CX34-62D-6F	C33-62D	749	1765	730	1746

DOWN-FLOW POSITION

Model Number	Coil Width	Furnace Width	Coil Height	Overall Height
CR33-24B-F	446	446	337	1353
CR33-30/36B-F	446	446	410	1426
CR33-30/36C-F	533	533	410	1426
CR33-48B-F	533	446	508	1524
CR33-48C-F	533	533	508	1524
CR33-50/60C-F	622	533	600	1362
CR33-60D-F	622	622	600	1362

HORIZONTAL POSITION

Model Number		A	B
CH33-36B-2F	CH33-42B-2F	673	1689
CH33-36C-2F	CH33-48C-2F		
	CH33-60D-2F		
CH33-44/48B-2F	CH33-62D-2F	800	1816
CH33-50/60C-2F			

OPTIONAL ACCESSORY DIMENSIONS - MM

DOWN-FLOW COMBUSTIBLE FLOOR BASE

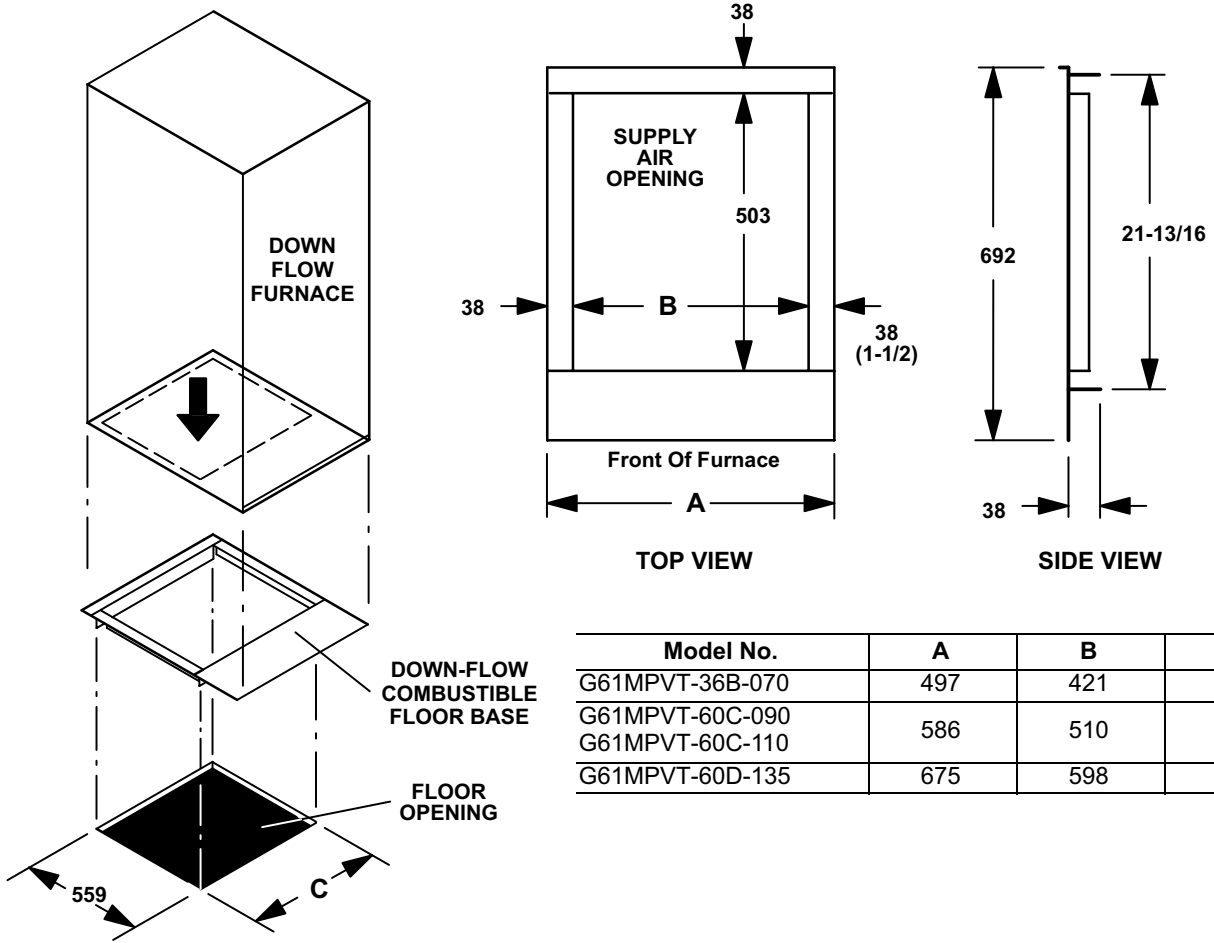

Model No.	A	B	C
G61MPVT-36B-070	497	421	476
G61MPVT-60C-090	586	510	565
G61MPVT-60C-110	675	598	654

OPTIONAL ACCESSORY DIMENSIONS - MM

**CONCENTRIC WALL
TERMINATION APPLICATIONS**

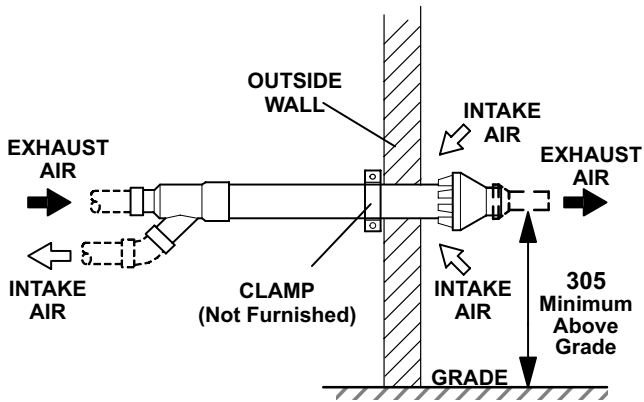

**CONCENTRIC ROOF
TERMINATION APPLICATIONS**

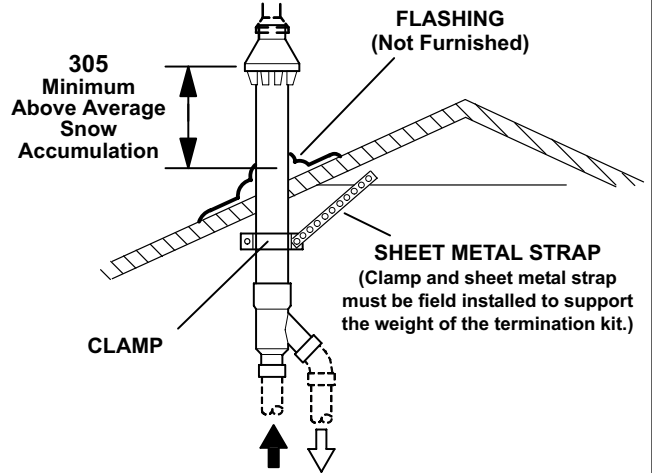

**71M80/69M29 - 2 inch
60L46 — 3 inch**
See Installation Instructions for specific usage.

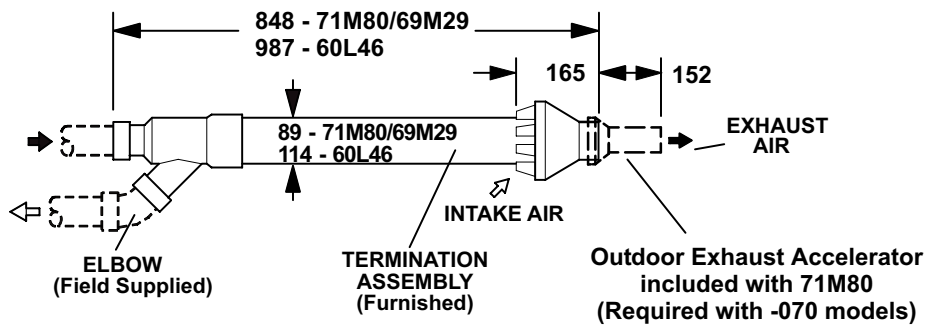

BLOWER DATA - 0 through 200 Pa External Static Pressure Range

G61MPVT-36B-070 BLOWER PERFORMANCE (less filter)

"ADJUST" Switch Positions	Speed Switch Positions							
	Second Stage "HEAT" Speed - L/s				Second Stage "COOL" Speed - L/s			
	1	1 2	3	4	1	2	3	1 4
+	420	485	610	630	480	560	605	660
1 NORM	385	445	545	570	440	500	545	600
—	N/A	395	480	495	390	450	475	520
"ADJUST" Switch Positions	First Stage "HEAT" Speed - L/s				First Stage "COOL" Speed - L/s			
	1	1 2	3	4	1	2	3	1 4
	+	385	440	545	570	345	385	410
1 NORM	360	410	495	515	320	355	375	405
—	N/A	365	440	455	295	330	345	365

G61MPVT-60C-090 BLOWER PERFORMANCE (less filter)

Bottom Return Air, Return Air from Both Sides or Return Air from Bottom and One Side.

"ADJUST" Switch Positions	Speed Switch Positions							
	Second Stage "HEAT" Speed - L/s				Second Stage "COOL" Speed - L/s			
	1	1 2	3	4	1	2	3	1 4
+	710	790	885	985	755	805	910	1020
1 NORM	640	730	810	895	680	735	830	925
—	565	645	725	800	600	650	750	830
"ADJUST" Switch Positions	First Stage "HEAT" Speed - L/s				First Stage "COOL" Speed - L/s			
	1	1 2	3	4	1	2	3	1 4
	+	640	735	815	900	520	560	640
1 NORM	575	665	750	820	470	510	570	635
—	520	580	665	740	420	455	515	575

G61MPVT-60C-090 BLOWER PERFORMANCE (less filter)

Single Side Return Air - Air volumes in bold require field fabricated transition to accommodate 508 x 635 x 25 mm cleanable air filter in order to maintain proper air velocity across the filter.

"ADJUST" Switch Positions	Speed Switch Positions							
	Second Stage "HEAT" Speed - L/s				Second Stage "COOL" Speed - L/s			
	1	1 2	3	4	1	2	3	1 4
+	685	775	860	970	745	800	895	1010
1 NORM	625	710	800	885	665	722	820	915
—	550	625	710	785	590	640	735	820
"ADJUST" Switch Positions	First Stage "HEAT" Speed - L/s				First Stage "COOL" Speed - L/s			
	1	1 2	3	4	1	2	3	1 4
	+	620	710	800	885	510	545	620
1 NORM	560	645	730	810	465	500	560	630
—	505	570	645	715	410	440	500	560

G61MPVT-60C-110 BLOWER PERFORMANCE (less filter)

Bottom Return Air, Return Air from Both Sides or Return Air from Bottom and One Side.

"ADJUST" Switch Positions	Speed Switch Positions							
	Second Stage "HEAT" Speed - L/s				Second Stage "COOL" Speed - L/s			
	1	1 2	3	4	1	2	3	1 4
+	710	805	905	1005	765	825	940	1045
1 NORM	645	740	830	915	690	745	845	940
—	570	650	740	820	610	665	755	845
"ADJUST" Switch Positions	First Stage "HEAT" Speed - L/s				First Stage "COOL" Speed - L/s			
	1	1 2	3	4	1	2	3	1 4
	+	645	740	830	920	445	480	545
1 NORM	580	670	755	840	395	430	495	555
—	520	590	670	745	350	375	434	495

¹ Factory default jumper setting.

N/A - First and second stage HEAT positions shown cannot be used on this model.

NOTES - The effect of static pressure is included in air volumes shown.

First stage HEAT is approximately **91%** of the same second stage HEAT speed position.

First stage COOL (two-stage air conditioning units only) is approximately **70%** of the same second stage COOL speed position.

Continuous Fan Only speed is approximately **38%** of the same second stage COOL speed position - minimum 235 L/s.

BLOWER DATA - 0 through 200 Pa External Static Pressure Range

G61MPVT-60C-110 BLOWER PERFORMANCE (less filter)

Single Side Return Air - Air volumes in bold require field fabricated transition to accommodate 508 x 635 x 25 mm cleanable air filter in order to maintain proper air velocity across the filter.

"ADJUST" Switch Positions	Speed Switch Positions							
	Second Stage "HEAT" Speed - L/s				Second Stage "COOL" Speed - L/s			
	1	1 2	3	4	1	2	3	1 4
+	700	790	880	980	750	800	900	1010
¹ NORM	635	720	815	895	675	725	820	910
—	555	630	710	790	605	655	740	830
"ADJUST" Switch Positions	First Stage "HEAT" Speed - L/s				First Stage "COOL" Speed - L/s			
	1	1 2	3	4	1	2	3	1 4
	+	625	710	800	880	440	485	545
¹ NORM	565	645	730	810	395	430	495	555
—	510	570	645	720	355	375	435	495

G61MPVT-60D-135 BLOWER PERFORMANCE (less filter)

Bottom Return Air, Return Air from Both Sides or Return Air from Bottom and One Side.

"ADJUST" Switch Positions	Speed Switch Positions							
	Second Stage "HEAT" Speed - L/s				Second Stage "COOL" Speed - L/s			
	1	1 2	3	4	1	2	3	1 4
+	710	805	895	995	760	815	915	1035
¹ NORM	645	730	820	905	685	745	840	935
—	580	650	730	810	615	660	755	840
"ADJUST" Switch Positions	First Stage "HEAT" Speed - L/s				First Stage "COOL" Speed - L/s			
	1	1 2	3	4	1	2	3	1 4
	+	655	740	830	910	535	570	645
¹ NORM	590	670	750	835	485	520	580	655
—	535	595	675	750	430	465	525	580

¹ Factory default jumper setting.

N/A - First and second stage HEAT positions shown cannot be used on this model.

NOTES - The effect of static pressure is included in air volumes shown.

First stage HEAT is approximately **91%** of the same second stage HEAT speed position.

First stage COOL (two-stage air conditioning units only) is approximately **70%** of the same second stage COOL speed position.

Continuous Fan Only speed is approximately **38%** of the same second stage COOL speed position - minimum 235 L/s.

REVISIONS

Sections	Description of Change
Specification	Changed dimensions for the blower wheels.



Visit us at www.lennox.com
For the latest technical information, www.lennox.com

NOTE - Due to Lennox' ongoing commitment to quality, Specifications, Ratings and Dimensions subject to change without notice and without incurring liability. Improper installation, adjustment, alteration, service or maintenance can cause property damage or personal injury. Installation and service must be performed by a qualified installer and servicing agency.