

1.5 to 5 Tons

MODEL NUMBER IDENTIFICATION

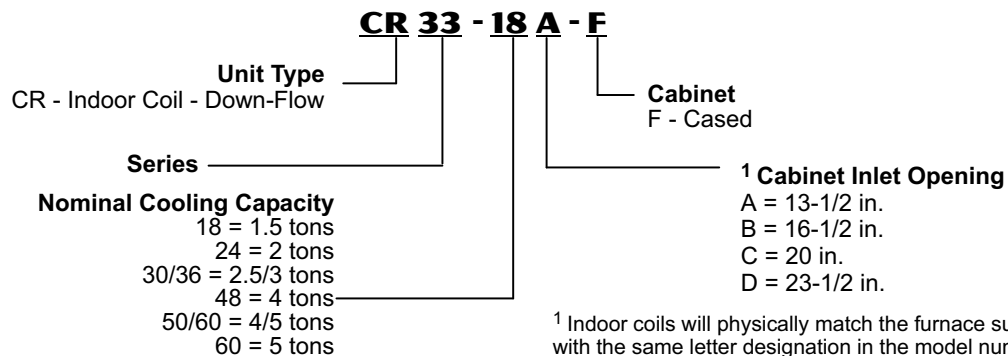

FEATURES

CONTENTS

Air Resistance Page 3
 Dimensions Page 4
 Features Pages 1-2
 Model Number Identification Page 1
 Specifications Page 2

WARRANTY

All covered components — limited warranty for **five years** in residential applications, one year warranty in non-residential applications.
 Refer to Lennox Equipment Limited Warranty certificate included with equipment for details.

APPLICATIONS

Lennox designed down-flow indoor coils can easily be installed with most Lennox down-flow furnaces.
 Applicable to expansion valve or RFCIV systems.
 Expansion valve systems require optional field installed kit.
 See bulletins in section Air Conditioners for cooling capacities.
 See bulletins in section Heat Pump Outdoor Units for cooling and heating capacities.

TESTED

Tested with matching air conditioners and heat pump units.
 Rated in accordance with ARI Standard 210/240 conditions and DOE test procedures.
 Air resistance tests from Lennox Laboratory air test chamber.

CABINET

Cabinets insulated with thick fiberglass insulation.
 Constructed of painted, heavy-gauge steel.
 Coil slides out of cabinet for ease of servicing
 Removable panels provide access to coil.
 Refrigerant lines extend outside of cabinet for easy installation.
 See dimension drawing.

Furnace Match-Up

Coils match openings of corresponding Lennox furnaces with same letter designation in model number. No adaptor required.

FEATURES

REFRIGERANT SYSTEM

Coil Construction

- Durable copper tubing.
- Ripple-edged aluminum fins.
- Lanced fins provide maximum exposure of fin surface to air stream.
- Rifled tubing provides superior refrigerant heat transfer.
- Twin coil construction assembled in a "V" configuration for large surface area.
- Corrosion resistant plastic drain pan with dual fpt drain connections.
- Liquid line seal nut section furnished for installation of expansion valve or RFCIV orifice.
- Suction/vapor line has 1/4 in. port external to cabinet for expansion valve usage with external equalizer.
- Sweat connections on both liquid and suction lines.
- High pressure testing insures leakproof construction.

Refrigerant Control Choice

- All models applicable to Lennox RFCIV™ refrigerant metering system when matched with specific air conditioners. See Air Conditioners bulletins for applications.
- Optional expansion valve or check/expansion valve is required in most applications and must be ordered extra.

Refrigerant Flow Control IV

RFCIV accurately meters refrigerant in system. Refrigerant control is accomplished by exact sizing of refrigerant metering orifice. Principle of Lennox RFCIV system involves matching evaporator coil with proper bore size of orifice in metering device. RFCIV system equalizes pressure shortly after compressor stops, unit starts unloaded, eliminating need for additional controls.

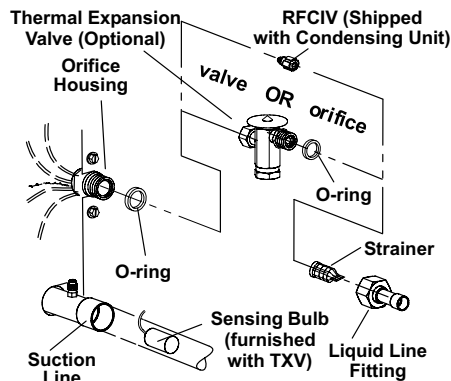

OPTIONS

Expansion Valve Kits

- Expansion valve available for field installation.
- See Air Conditioners and Heat Pump Outdoor Units bulletins for expansion valve/check expansion valve kit selection.

SPECIFICATIONS

1.5 TO 3 TON

General Data		Model No.	CR33-18A-F	CR33-24A-F	CR33-24B-F	CR33-30/36A-F	CR33-30/36B-F
		Nominal size - tons	1.5	2	3	2.5/3	2.5/3
Line connections in. (mm)	Suction / vapor o.d. - sweat		3/4 (19)	3/4 (19)	3/4 (19)	3/4 (19)	3/4 (19)
	Liquid o.d. - sweat		3/8 (9.5)	3/8 (9.5)	3/8 (9.5)	3/8 (9.5)	3/8 (9.5)
	Condensate drain (fpt)		(2) 3/4 (19)	(2) 3/4 (19)	(2) 3/4 (19)	(2) 3/4 (19)	(2) 3/4 (19)
Indoor Coil	Net face area sq. ft. (m ²)		3.5 (0.33)	3.21 (0.30)	3.21 (0.30)	4.08 (0.38)	4.08 (0.38)
	Tube diameter - in. (mm)		3/8 (9.5)	3/8 (9.5)	3/8 (9.5)	3/8 (9.5)	3/8 (9.5)
	Number of rows		2	3	3	3	3
	Fins per inch (m)		18 (709)	10 (394)	10 (394)	10 (394)	10 (394)
Shipping weight	lbs. (kg) 1 package		44 (20)	44 (20)	49 (22)	58 (26)	57 (26)

SPECIFICATIONS

2 TO 5 TON

General Data		Model No.	CR33-30/36C-F	CR33-48B-F	CR33-48C-F	CR33-50/60C-F	CR33-60D-F
		Nominal size - tons	2.5/3	4	4	4/5	5
Line connections in. (mm)	Suction / vapor o.d. - sweat		3/4 (19)	7/8 (22.2)	7/8 (22.2)	7/8 (22.2)	7/8 (22.2)
	Liquid o.d. - sweat		3/8 (9.5)	3/8 (9.5)	3/8 (9.5)	3/8 (9.5)	3/8 (9.5)
	Condensate drain (fpt)		(2) 3/4 (19)	(2) 3/4 (19)	(2) 3/4 (19)	(2) 3/4 (19)	(2) 3/4 (19)
Indoor Coil	Net face area sq. ft. (m ²)		4.08 (0.38)	5.25 (0.49)	5.25 (0.49)	6.42 (0.60)	6.42 (0.60)
	Tube diameter - in. (mm)		3/8 (9.5)	3/8 (9.5)	3/8 (9.5)	3/8 (9.5)	3/8 (9.5)
	Number of rows		3	3	3	3	3
	Fins per inch (m)		10 (394)	10 (394)	10 (394)	10 (394)	10 (394)
Shipping weight	lbs. (kg) 1 package		60 (27)	72 (33)	71 (32)	85 (39)	84 (38)

AIR RESISTANCE

Model No.	Dry Coil				Wet Coil				Model No.	Dry Coil				Wet Coil				
	Air Volume		Total Resistance		Air Volume		Total Resistance			Air Volume		Total Resistance		Air Volume		Total Resistance		
	cfm	L/s	in. w.g.	Pa	cfm	L/s	in. w.g.	Pa		cfm	L/s	in. w.g.	Pa	cfm	L/s	in. w.g.	Pa	
CR33 -18A-F	370	175	0.05	12	255	121	0.05	12	CR33 -30/36C-F	600	285	0.06	15	600	283	0.07	17	
	510	240	0.08	19	305	144	0.07	17		700	330	0.08	20	700	330	0.10	25	
	645	305	0.10	25	355	167	0.09	22		800	380	0.10	25	800	378	0.13	32	
	815	385	0.15	37	395	186	0.12	30		900	425	0.13	32	900	425	0.17	42	
	980	465	0.20	50	435	205	0.15	37		1000	470	0.16	40	1000	472	0.21	52	
	1115	525	0.25	62	520	245	0.18	44		1100	520	0.19	47	1100	519	0.25	62	
	1250	590	0.30	75	600	284	0.20	50		1200	565	0.22	55	1200	566	0.29	72	
	1395	660	0.35	87	690	325	0.25	62		1300	615	0.26	65	1300	614	0.34	85	
	1535	725	0.40	100	775	365	0.30	75		1400	660	0.29	72	1400	661	0.38	95	
	1645	775	0.45	112	845	399	0.35	86		CR33 -48B-F	1200	565	0.14	35	1200	566	0.17	42
	1760	830	0.50	125	920	433	0.39	97			1300	615	0.16	40	1300	614	0.20	50
	1870	880	0.55	137	1505	711	0.50	125			1400	660	0.19	47	1400	661	0.23	57
	CR33 -24A-F	315	150	0.05	12	335	157	0.05			12	1500	710	0.22	55	1500	708	0.26
465		220	0.09	22	490	231	0.10	25	1600		755	0.25	62	1600	755	0.29	72	
595		280	0.14	35	600	284	0.15	37	1700		800	0.28	70	1700	802	0.32	80	
725		345	0.20	50	705	332	0.20	50	1800		850	0.30	75	1800	850	0.36	90	
825		390	0.25	62	790	373	0.25	62	1900	895	0.34	85	1900	897	0.42	105		
910		430	0.30	75	870	411	0.30	75	2000	945	0.37	92	2000	944	0.45	112		
1000		470	0.35	87	940	444	0.35	87	CR33 -48C-F	595	280	0.05	12	575	271	0.05	12	
1080		510	0.40	100	1020	481	0.40	100		860	405	0.10	25	820	386	0.10	25	
1225	580	0.50	125	1090	514	0.45	112	1060		500	0.15	37	995	469	0.15	37		
1370	645	0.60	150	1160	547	0.51	127	1235		580	0.20	50	1170	551	0.20	50		
CR33 -24B-F	400	190	0.06	15	400	189	0.07	17		1395	655	0.25	62	1320	623	0.25	62	
	500	235	0.09	22	500	236	0.10	25		1545	730	0.30	75	1445	682	0.30	75	
	600	285	0.13	32	600	283	0.15	37		1675	790	0.35	87	1575	744	0.35	87	
	700	330	0.17	42	700	330	0.20	50	1805	850	0.40	100	1710	807	0.40	100		
	800	380	0.23	57	800	378	0.26	65	1925	910	0.45	112	1825	861	0.45	112		
	900	425	0.27	67	900	425	0.32	80	2030	960	0.50	125	1915	904	0.50	125		
	1000	470	0.33	82	1000	472	0.39	97	CR33 -50/60C-F	1395	660	0.17	42	1400	661	0.19	47	
	1100	520	0.39	97	1100	519	0.46	115		1500	710	0.19	47	1500	707	0.22	55	
	1200	565	0.47	117	1200	566	0.54	135		1605	755	0.21	52	1600	755	0.24	60	
	CR33 -30/36A-F	600	285	0.10	25	600	283	0.10		25	1700	805	0.24	60	1710	807	0.27	67
700		330	0.13	32	700	330	0.14	35		1805	850	0.27	67	1800	850	0.31	77	
800		380	0.16	40	800	378	0.18	45		1905	900	0.29	72	1890	892	0.33	82	
900		425	0.20	50	900	425	0.23	57		2000	945	0.32	80	2000	944	0.36	90	
1000		470	0.24	60	1000	472	0.27	67	2105	995	0.35	87	2105	993	0.40	100		
1100		520	0.28	70	1100	519	0.32	80	2200	1040	0.39	97	2190	1034	0.45	112		
1200		565	0.33	82	1200	566	0.38	95	CR33 -60D-F	1395	660	0.17	42	1400	661	0.19	47	
1300		615	0.38	95	1300	614	0.43	107		1500	710	0.19	47	1500	707	0.22	55	
1400	665	0.43	107	1400	661	0.49	122	1605		755	0.21	52	1600	755	0.24	60		
CR33 -30/36B-F	525	245	0.05	12	410	194	0.05	12		1700	805	0.24	60	1710	807	0.27	67	
	660	310	0.08	19	495	233	0.08	19		1805	850	0.27	67	1800	850	0.31	77	
	795	375	0.10	25	580	273	0.10	25		1905	900	0.29	72	1890	892	0.33	82	
	980	465	0.15	37	785	371	0.15	37		2000	945	0.32	80	2000	944	0.36	90	
	1165	550	0.20	50	995	469	0.20	50	2105	995	0.35	87	2105	993	0.40	100		
	1320	625	0.25	62	1155	546	0.25	62	2200	1040	0.39	97	2190	1034	0.45	112		
	1475	695	0.30	75	1320	624	0.30	75	CR33 -60D-F	1395	660	0.17	42	1400	661	0.19	47	
	1605	760	0.35	87	1465	692	0.35	87		1500	710	0.19	47	1500	707	0.22	55	
	1735	820	0.40	100	1610	761	0.40	100		1605	755	0.21	52	1600	755	0.24	60	
	1805	855	0.43	107	1730	816	0.45	112		1700	805	0.24	60	1710	807	0.27	67	
1875	885	0.46	115	1850	872	0.50	125	1805		850	0.27	67	1800	850	0.31	77		
								1905		900	0.29	72	1890	892	0.33	82		

DIMENSIONS - INCHES (MM)

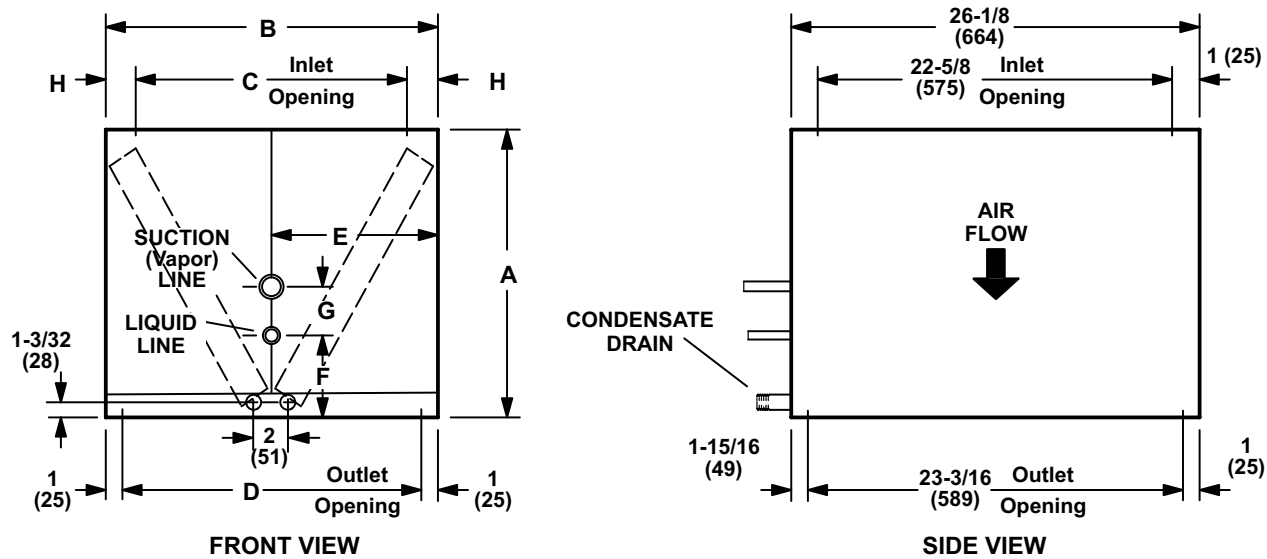

Model Number	A		B		C		D		E		F		G		H	
	in.	mm	in.	mm	in.	mm	in.	mm	in.	mm	in.	mm	in.	mm	in.	mm
CR33-18A-F	14-1/8	359	17-1/2	445	13-1/2	343	15-1/2	394	8-3/4	222	6-1/4	159	3	76	2	51
CR33-24A-F	13-1/4	337	17-1/2	445	13-1/2	343	15-1/2	394	8-3/4	222	6-1/4	159	3	76	2	51
CR33-24B-F	13-1/4	337	17-1/2	445	16-1/2	419	15-1/2	394	8-3/4	222	6-1/4	159	3	76	1/2	13
CR33-30/36A-F	16-1/8	410	17-1/2	445	13-1/2	343	15-1/2	394	8-3/4	222	6-1/8	156	3	76	2	51
CR33-30/36B-F	16-1/8	410	17-1/2	445	16-1/2	419	15-1/2	394	8-3/4	222	6-1/8	156	3	76	1/2	13
CR33-30/36C-F	16-1/8	410	21	533	20	508	19	483	10-1/2	267	6-1/8	156	3	76	1/2	13
CR33-48B-F	20	508	21	533	16-1/2	419	19	483	10-1/2	267	8-1/8	206	4	102	2-1/4	57
CR33-48C-F	20	508	21	533	20	508	19	483	10-1/2	267	8-1/8	206	4	102	1/2	13
CR33-50/60C-F	23-5/8	600	24-1/2	622	20	508	22-1/2	572	12-1/4	311	12-5/8	321	4	102	2-1/4	57
CR33-60D-F	23-5/8	600	24-1/2	622	23-1/2	597	22-1/2	572	12-1/4	311	12-5/8	321	4	102	1/2	13



Visit us at www.lennox.com
For the latest technical information, www.lennoxdagenet.com
Contact us at 1-800-4-LENNOX

NOTE - Due to Lennox' ongoing commitment to quality, Specifications, Ratings and Dimensions subject to change without notice and without incurring liability.
Improper installation, adjustment, alteration, service or maintenance can cause property damage or personal injury.
Installation and service must be performed by a qualified installer and servicing agency.

©2005 Lennox Industries Inc.